

QC157.L67 1982x
C.1

LOS ALAMOS SHOCK WAVE PROFILE DATA

SCANNED JAN 29 1999



LOS ALAMOS NATIONAL LABORATORY

3 9338 00328 8684

LOS ALAMOS SERIES ON DYNAMIC MATERIAL PROPERTIES

LOS ALAMOS DATA CENTER
FOR DYNAMIC MATERIAL PROPERTIES

TECHNICAL COMMITTEE

Charles L. Mader	Program Manager
Terry R. Gibbs	Explosives Data Editor
Charles E. Morris	Shock Wave Profile Editor
Stanley P. Marsh	Equation of State Editor
Alphonse Popolato	Explosives Data Editor
Martha S. Hoyt	Computer Applications Analyst
Sharon L. Crane	Technical Editor

John F. Barnes
Richard D. Dick
John W. Hopson, Jr.
James N. Johnson
Elisabeth Marshall
Timothy R. Neal
Suzanne W. Peterson
Raymond N. Rogers
John W. Taylor
Melvin T. Thieme
Jerry D. Wackerle
John M. Walsh



LOS ALAMOS SHOCK WAVE PROFILE DATA

Editor — Charles E. Morris

EXPERIMENTERS

W. C. Davis
J. N. Fritz
M. J. Ginsberg
P. M. Halleck
J. W. Hopson
J. O. Johnson
J. A. Morgan
C. E. Morris
Bart Olinger
M. H. Rice
J. W. Taylor
Jerry Wackerle

UNIVERSITY OF CALIFORNIA PRESS
Berkeley • Los Angeles • London

Photocomposition by Alice Creek
University of California Press
Berkeley and Los Angeles, California
University of California Press, Ltd.
London, England
Copyright © 1982 by
The Regents of the University of California
ISBN 0-520-04013-9
Series ISBN 0-520-04007-4
Library of Congress Catalog Card Number: 81-70654
Printed in the United States of America

1 2 3 4 5 6 7 8 9

CONTENTS

INTRODUCTION	1
ELEMENTS	13
Beryllium, free-surface capacitor	14
Boron, free-surface capacitor	20
Carbon, ASM probe	21
Carbon (PT 0178 graphite) free-surface capacitor	24
Germanium [100], free-surface capacitor	25
Iron, Armco, free-surface capacitor	26
Lead, free-surface capacitor	37
Mercury, free-surface capacitor	38
Niobium, free-surface capacitor	39
Silicon [100], free-surface capacitor	40
Tantalum, free-surface capacitor	41
Thorium, free-surface capacitor	44
Tin, free-surface capacitor	45
Titanium, free-surface capacitor	46
Tungsten, free-surface capacitor	47
Uranium, free-surface capacitor	48
Uranium, embedded Manganin gage	54
Zirconium, free-surface capacitor	60
ALLOYS	61
Aluminum, free-surface capacitor	62
Aluminum, ASM probe	74
Aluminum/HE, free-surface capacitor	79
Copper, free-surface capacitor	80
Copper, embedded Manganin gage	82

Copper, ASM probe	96
Gold, free-surface capacitor	101
Iron, free-surface capacitor	102
Lead, free-surface capacitor	103
Magnesium, free-surface capacitor	104
Molybdenum, free-surface capacitor	106
Steel, free-surface capacitor	108
Tantalum, free-surface capacitor	127
Tungsten, free-surface capacitor	128
Uranium, free-surface capacitor	134
Uranium, embedded Manganin gage	138
Uranium, free-surface capacitor	142
MINERALS AND COMPOUNDS	151
Alumina, free-surface capacitor	152
Beryllium oxide, free-surface capacitor	156
Boron carbide, free-surface capacitor	161
Boron carbide, ASM probe	162
Boron nitride, free-surface capacitor	171
Calcium carbonate, free-surface capacitor	172
Hafnium titanate, free-surface capacitor	173
Lithium hydride, free-surface capacitor	175
Sodium chloride, ASM probe	181
Spinel, free-surface capacitor	187
Tantalum carbide, free-surface capacitor	190
Tantalum carbide carbon, free-surface capacitor	191
Titanium boride, free-surface capacitor	192
Tungsten carbide, free-surface capacitor	194
Zirconium boride, free-surface capacitor	200
ROCKS AND MIXTURES OF MINERALS	201
Corundum, ASM probe	202
Devonian gas shale, embedded Manganin gage	204
Diabase, free-surface capacitor	220
Silicon dioxide (novaculite), ASM probe	221
PLASTICS	223
Lexan, embedded Manganin gage	224
Polyethylene, ASM probe	226
Polymethyl methacrylate (PMMA), embedded Manganin gage	228

HIGH EXPLOSIVES, HIGH-EXPLOSIVE SIMULANTS, AND PROPELLANTS	237
Baratol, embedded Manganin gage	238
Comp B, ASM probe	240
Comp B-3, embedded Manganin gage	242
Inert 900-10, embedded Manganin gage	244
Inert 905-03, embedded Manganin gage	246
Inert 900-19, embedded Manganin gage	248
PBX 9404, ASM probe	250
PBX 9404, multiple embedded Manganin gage	264
PBX 9501, embedded Manganin gage	280
PBX 9502, embedded Manganin gage	282
PETN, pressed, Manganin gage impact face	284
PETN, pressed, multiple embedded Manganin gage	286
PETN, pressed, quartz-gage front back	294
PETN, single-crystal, quartz-gage front back	338
TATB, superfine, embedded Manganin gage	366
TNT, embedded Manganin gage	386
TP-N1028 Class VII propellant, embedded Manganin gage	388
UTP-20930 Class VII propellant, embedded Manganin gage	394
VWC-2 Class VII propellant, embedded Manganin gage	400
X 0290, ASM probe	408
EXPLOSIVES-METAL FREE-RUN SYSTEMS	413
Comp B-2024 aluminum, ASM probe	414
Comp B-aluminum, ASM probe	440
Comp B-6061 aluminum, ASM probe	445
Comp B-copper, ASM probe	446
PBX 9404-2024 aluminum, ASM probe	451
PBX 9404-6061 aluminum, ASM probe	458
PBX 9404-copper, ASM probe	462
PBX 9404-304 stainless steel, ASM probe	466
REFERENCES	470
GLOSSARY	474
APPENDIX	477
Hugoniot Elastic Limits	477
Longitudinal and Shear Wave Velocities in Polycrystalline Aggregates	480
INDEX	484

INTRODUCTION

This volume of the Los Alamos Series on Dynamic Material Properties is designed to provide a single source of shock wave profiles determined at the Los Alamos National Laboratory.

The first wave profiles were measured at Los Alamos National Laboratory by Minshall (1955) using high-precision pin work by which a very accurate x - t map was made of the free-surface displacement and the two-wave structure indicating elastic-plastic flow was demonstrated. Later Minshall and his coworkers (1956) established the polymorphism of iron in a work now considered a classic. Other phase transitions studied by Minshall and his coworkers include bismuth (1957), antimony (1962), and many iron alloys (1961). To eliminate the need to differentiate x - t data and the subsequent loss of precision, techniques were developed to measure directly time-resolved stress and velocity wave profiles. R. G. McQueen, one of the workers in the field at the time, reminisces:

Historical Perspective by Robert G. McQueen

It was an exciting time in shock wave physics when the first efforts were made to make time-resolved pressure and velocity measurements. These efforts were directed primarily to resolve the structure in shocks due to elastic-plastic flow. The basic phenomena were well understood but the details of the mechanism governing the flow were not. It was recognized that if the measurements could be made, elastic-plastic phenomena could be studied at the highest possible strain rates, those governed by the elastic properties of the material itself. The basic difficulty encountered in making the measurements did not lie with the time resolution. For example, if the wave coming through a 5-mm sample had a longitudinal velocity of 5 mm/ μ s and a plastic wave velocity of 4 mm/ μ s there would be 0.25 μ s to study the elastic to plastic behavior. However, for a material like iron the pressure of the elastic wave of about 1 GPa would result in a velocity of only 0.05 mm/ μ s, which means that the measurements must be

made in a distance of less than 0.015 mm. This is the problem that Minshall overcame by meticulously locating shorting pins on the surface of the iron plate he used in making his classic measurements of the amplitude of the elastic wave of the shocked iron. This work was an inspiration to those working in shock wave physics. It was also obvious that there were very few people around that could do the type of work that Stan Minshall did and that there just had to be a better way to make these measurements. It was during this time that a concentrated effort was made to develop techniques to resolve the elastic-plastic behavior of shock-loaded materials. There were three efforts: two at Los Alamos, the Free-Surface Condenser Method devised and developed by Mel Rice, the Optical Lever Arm by Stan Marsh and me, and the Quartz Pressure Transducer by Frank Neilson and his group at Sandia. Although the basic concepts seemed quite straightforward, the developments of successful working systems were more difficult. All three groups did some of their development work using iron because we knew from Minshall's work that there would be a measurable effect. I do not remember the problems the quartz gage and the capacitor technique encountered although we had several meetings to discuss our progress. In developing the optical lever technique problems included sample preparation with a mirror finish, modifying our smear camera to do a job it was not designed to do, developing low-pressure HE systems and high-intensity light sources, and the most bothersome thing of all, originally, developing a method for optically aligning the system.

It was with some pleasure and excitement that Stan and I got our first good record. However, our joy was short-lived when we showed it to Mac Walsh, who was Group Leader here at Ancho Canyon Site. I think his remark was something like this, "I'm sorry, guys, but you're not out of the woods yet. This record shows a decreasing elastic wave velocity." And so it did, but the following week Rice obtained his first successful iron record showing the same phenomena. Neilson's group observed the same thing a week or so later. I have always thought it was interesting that these three endeavors initiated at the same time also came to fruition within a few days of one another. It was also exciting that one of the first materials investigated exhibited such a well-defined stress relaxation behavior. This was indeed a most interesting time.

Rice (1961) developed the free-surface capacitor technique, which measured directly the free-surface velocities of shocked loaded targets. The first wave profile measurements were made in 1959, and the results were published in 1961. This technique has been very successful in the study of low-amplitude elastic and plastic waves generated by impact of projectiles from smooth-bore guns. The stress relaxation of elastic waves in Armco iron was one of the initial discoveries made using this technique [Taylor and Rice (1963), Taylor (1965)], stimulating much research in the rheology of metals under shock loading.

A variety of techniques has been used at Los Alamos to measure wave profiles. Some of the techniques include the quartz gage [Neilson (1961)], the wire reflection technique

[Davis and Craig (1961)], the inclined mirror [Fowles (1962)], the optical lever technique [McQueen (1964)], the Manganin gage [Fuller and Price (1962)], the ASM probe [Fritz and Morgan (1973)], and the VISAR [Barker and Hollenbach (1972)]. A few of the experimental techniques listed were used only briefly whereas others were used extensively. The most widely used techniques at Los Alamos over the last 20 years were the free-surface capacitor, the quartz gage, the Manganin gage, and the axially symmetric magnetic (ASM) probe. Wave profiles of these techniques will be presented in this compendium, and for readers who are unfamiliar with these techniques, each is described briefly.

The wave profiles presented are arranged by material, independent of the experimental technique used. The materials are divided into six classifications similar to those used in Marsh's *LASL Shock Hugoniot Data* volume: elements; alloys; minerals and compounds; rocks and mixtures of minerals; plastics; and high explosives, high-explosive simulants, and propellants.

The letters and numerals found in some of the shock wave profiles are defined under "Graph Symbols" in the glossary.

The appendix lists the longitudinal and shear velocities of materials investigated at Los Alamos. Marsh, using a pulse transmission technique, measured the velocities [Birch (1960) and Schreiber, Anderson, and Soga (1973)]. Transit times through the samples were determined by echo spacing or, for highly attenuating materials, by the difference in arrival times for samples of differing thickness. The estimated precision is 1/2-2% depending on the ultrasonic attenuation of the samples.

The appendix also has a compilation of Hugoniot elastic limit data obtained by the free-surface capacitor technique, the ASM probe, and the optical lever technique. Except in special cases where a "yield point" effect is well defined, the decision about exact amplitudes is made arbitrarily, but a consistent attempt is made to take the first point where the free-surface-velocity-versus-time record shows significant curvature. In most materials, the elastic limit is determined to within 10%; the error in some cases is probably even greater. In many materials the Hugoniot elastic limit is a decreasing function of sample thickness [Taylor and Rice (1963)], so the sample thickness is also listed.

FREE-SURFACE CAPACITOR TECHNIQUE

This capacitor technique developed by Rice (1961) measures the velocity of a plane conducting surface by electronically differentiating the signal and has proved valuable in studying elastic-plastic behavior of materials at modest pressures. The capacitor circuit used typically is shown in Fig. 1. Initially, the capacitor C_0 is charged to a constant voltage E_0 through two isolating resistors R_1 and R_2 . The capacitance C_0 is chosen large enough so that the voltage across it will be essentially constant during the measuring time interval. The variable capacitor C consists of a fixed disk positioned a known distance above the surface whose velocity is to be measured. The capacitor assembly is shown in Fig. 2. The

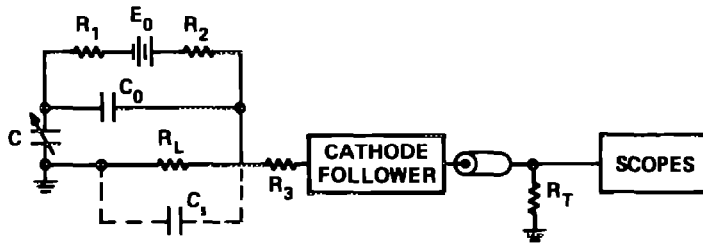

Fig. 1.
 Circuit for free-surface capacitor. Typical values for circuit parameters: $E_0 = 1200$ V, $R_1 = R_2 = 2$ M Ω , $C_0 = 0.01$ μ F, $C = 2$ pF, $C_1 = 12$ pF, $R_L = 1$ k Ω , $R_3 = 50$ Ω , and R_T is the terminating resistor for coaxial cable.

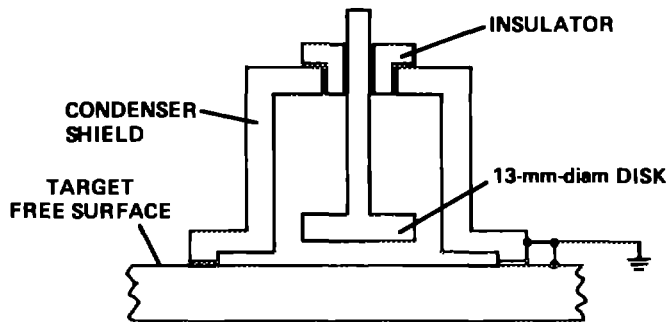

Fig. 2.
 Free-surface capacitor assembly.

fixed disk is mounted inside a metal shield, which restricts the free-surface area that contributes to the output signal. The target's free surface and the shield are at ground potential. In the early 1960s when experiments were performed on a 165-mm-diameter gun, the fixed disk's diameter was 25 mm. This diameter was reduced by a half when the experiments were transferred to a 51-mm gun. With target free-surface movement, the capacitance C increases, and because the charging voltage is held constant, the charge on C also increases, causing current flow and voltage development across the load resistor R_L . Neglecting transient effects, the output signal is given by

$$V(t) = E_0 R_L \frac{dC}{dx} U_{fs}(t) ,$$

where E_0 = charging voltage, R_L = load resistance, dC/dx = derivative of the capacitance with respect to the surface displacement x , and U_n = free-surface velocity. The output voltage across the resistor R_L is fed into a cathode follower, which powers the coaxial cable connecting the experimental assembly to the recording oscilloscopes. To minimize stray capacitance, the cathode follower and the capacitor circuit are mounted directly on the capacitor assembly and are expended with each shot. C_s is the sum of the cathode follower input capacitance and the circuit wiring stray capacitance. The resistor R_s being connected to the cathode follower grid is required for stability. The estimated time resolution of this measurement system is 10-20 ns, and the calibration accuracy is a few per cent [Taylor (1973)].

Before the capacitor assembly is used, it must be calibrated to determine dC/dx . Initially, dC/dx was determined by measuring the force of attraction between the capacitor disks using an analytical balance. The force of attraction is directly related to dC/dx through the equation $F = E^2 (dC/dx)/2$. For convenience and improved accuracy, the calibration scheme was changed later to Taylor's arrangement (1973), shown in Fig. 3, in which the capacitance was measured as a function of disk spacing with a General Radio model 1615 capacitance bridge. If the capacitor's diameter is at least ten times the spacing, the capacitance is represented very accurately by $C/C_0 = x_0/(x_0 - \Delta x)$, where Δx is the displacement.

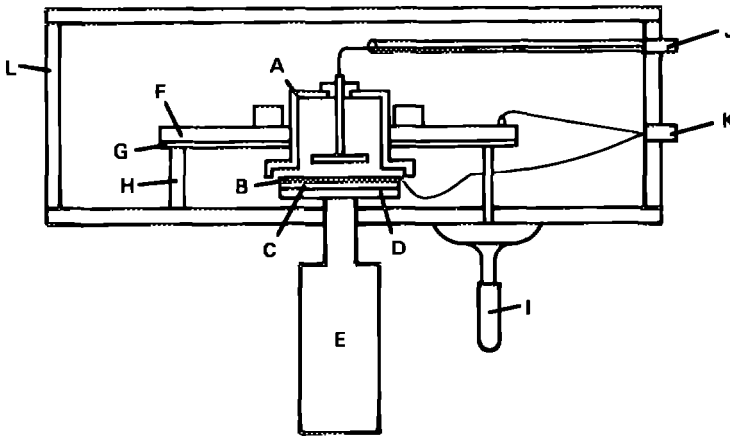

Fig. 3.

Calibrator for 0.5-10 pF dc capacitors. Capacitor A is held in mounting and centering fixture F, insulated by plastic spacer G from support points H and leveling micrometer I. The second plate of capacitor B is insulated from "case ground" L by insulator C supported on plate D, attached to the high-precision micrometer E. Connectors J and K are used with coaxial cables to connect to high- and low-impedance terminals, respectively, of a General Radio model 1615 capacitance bridge. The bridge is in the three-terminal mode, which automatically zeros out capacitance to case ground. Capacitance is then measured as a function of the position of plate B.

The free-surface capacitor technique applies to virtually all experiments involving shocks in metals as long as the main shock velocity does not exceed the material's longitudinal sound speed. Stronger shocks in metals produce an internally generated electrical signal (whose origin and mechanism remains a complete mystery), which mixes with the capacitor record and cannot be unfolded readily. The technique can also be used with insulators whenever a thin metal film on the material surface can be evaporated or otherwise deposited. If such materials are severely inhomogeneous and if some penalty in time resolution is acceptable, an aluminum or copper foil can be attached to the target surface.

THE AXIALLY SYMMETRIC MAGNETIC (ASM) PROBE

The ASM probe [Fritz and Morgan (1973)] has been used to study insulators [Morgan and Fritz (1979)], detonating explosives [Hayes and Fritz (1970), Davis (1976)], HE-driven metal plates, and the quasi-elastic structure in metals. Figure 4 illustrates an ASM probe assembly designed to measure the acceleration of an HE-driven metal plate. A permanent magnet provides a nonuniform steady magnetic field through which the plate is accelerated. Because of the magnetic field, eddy currents generated in the moving

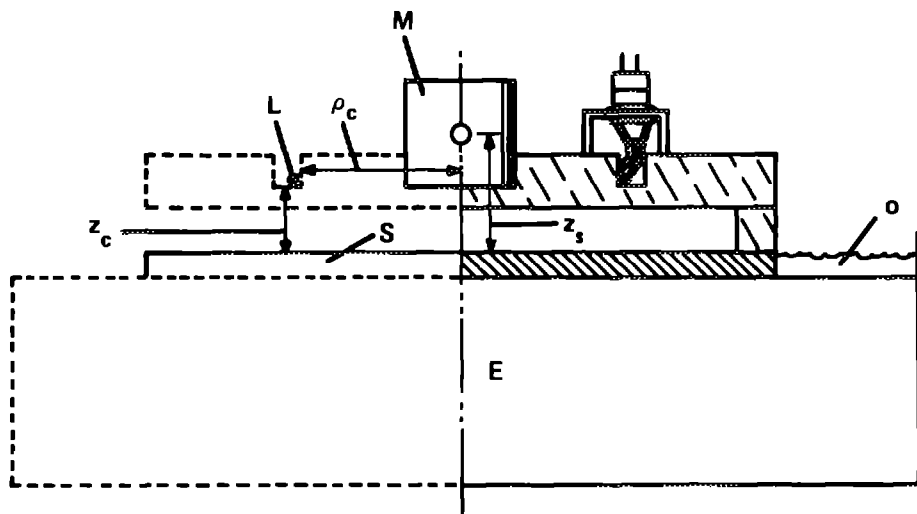

Fig. 4.

An axially symmetric magnetic probe assembly. The small ceramic magnet *M* is surrounded by a single turn of wire *L* connected to a cable. All are mounted on a premachined Lucite plate. Double arrows indicate critical dimensions. Sample *S* rests on explosive *E* and is surrounded by mineral oil *O*, which helps reduce electrical noise from the explosive. The sample-explosive joint is sealed with grease.

conductor produce a time-varying magnetic field. These time-varying fields induce a voltage signal in a pickup coil from which the velocity of the metal plate is determined [Fritz and Morgan (1973)]. The metal surface need not be a free-metal surface, as in this example, but may be a metal foil sandwiched between insulators or a metal surface beneath an insulator. The presence of the intervening insulator does not impair the probe functioning in most instances because the shock-induced permeability changes are parts per thousand in the worst cases (excluding ferromagnetic materials), and the shock-induced conductivity must be substantial before it effectively retards the field line motion and prevents the signal's appearance on the pickup coil. For example, detonated high explosives are transparent to the probe [Hayes and Fritz (1970), Davis (1976)]. The capability to look through shock-intervening insulators and the absence of electrical leads inside the high-pressure environment make the ASM probe an excellent tool for investigating material properties at high pressures. Measurements have been made on copper to 140-GPa pressure [Morris (1981)].

To obtain a calibrated response for the ASM probe, the pertinent physical dimensions z_c , z_p , and ρ_c are needed (see Fig. 4), in addition to the accurate measurement of $B_p(\rho, z)$ of the magnet over the range of interest. The axial Hall-effect field measuring probe maps out the B_p field. With this calibration and the recorded wave profile, the data are analyzed by an elaborate computer code solving the complete electrodynamic problem, including the metal foil's effect of finite conductivity [Fritz and Morgan (1973)]. An absolute check on the computed wave profile, $U_p(t)$, can be done with the experimental assembly shown in Fig. 4. The integrated particle velocity to impact time with the fiducial impact surface (FIS) should agree with the measured FIS spacing. Several experiments were done to check the probe's calibration. The rms deviation between the calculated and measured FIS spacing was 1.7%. This is a measure of the particle velocity accuracy using the ASM probe. The inherent probe time resolution is one nanosecond per centimeter coil diameter, but the time resolution is limited usually by the nonplanarity of impact and the resultant lack of simultaneous wave arrival.

One effective use of the ASM probe is to deposit 50- to 75-nm-thick aluminum films on insulating surfaces where timing information is desired. When the shock wave emerges at these surfaces, a brief twitch of the magnetic field [and thus a brief twitch of $V(t)$] is produced. These films have negligible surface conductivity and are active elements of the experiment only during large accelerations. This technique is often used in "front door" experiments, where the mechanical properties of insulators are being measured [Morgan and Fritz (1979)].

MANGANIN GAGE

Manganin is a copper-manganese alloy (typically, 84 wt% copper, 12 wt% manganese, and 4 wt% nickel), which has an extremely low temperature resistivity coefficient and a

relatively large positive piezoresistive coefficient. These characteristics enhance its use in shock-wave physics applications. The gages most commonly used are manufactured by Micro-Measurements from shunt-stock-grade Manganin using a photo-etch process. These gages are 0.013 mm thick and have a resistance of 50 Ω . To isolate the piezoresistive signal to the grid portion of the gage, the gage leads are overlaid with a few micrometers of copper. In applications where a durable gage is required, such as in the study of detonating explosives, a low-impedance (0.020- Ω) gage is used and is encapsulated with 0.25-mm-thick Teflon layers to prevent premature shunting [Vantine et al. (1980)]. The introduction of gages into detonating explosives can significantly change the flow. The Manganin gage locations are specified here as the distance from the impact surface to the actual gage location. For insulated gages, the distance is to the midpoint of the gage-insulator package.

Manganin gages are in-material stress gages and thus the records have no boundary effects that complicate interface measurements. The gages are used in studying wave evolution by embedding gages at varying depths in the target. The wave profiles can be analyzed then by a Lagrangian analysis scheme [Seaman (1974)]. A pulsed Wheatstone bridge circuit has aided Manganin gage work [Rice (1970) and Taylor (1973)] and is shown in Fig. 5. This circuit's output signal is approximately proportional to the fractional change in the gage resistance ($X = \Delta R_G / R_G$). Before firing, the bridge is balanced by varying R_3 until zero voltage is sensed at the output terminals AC. When this balanced condition is observed, $R_3 = R_G + R_L$. For this bridge configuration the input bridge impedance at AB matches a 50- Ω cable to avoid reflections in the gage cable. This circuit's output voltage is given by

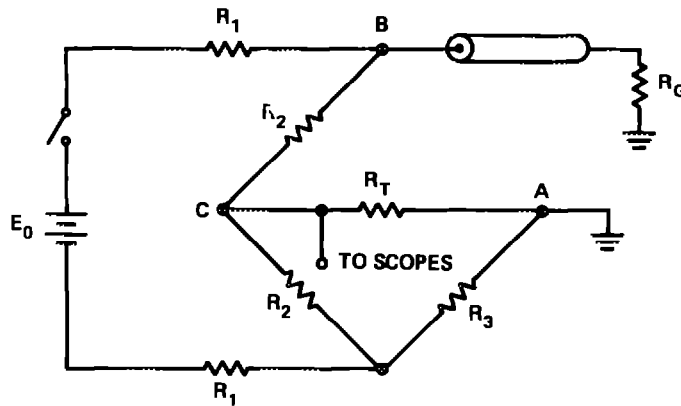

Fig. 5.

Wheatstone bridge circuit. Typical values for circuit parameters: $E_0 = 290$ V, $R_1 = 51$ Ω , $R_2 = 31$ Ω , $R_3 = 50.5$ Ω , $R_T = 50$ Ω , and $R_G = 50$ Ω .

$$\frac{V(t)}{E_0} = \frac{AX}{(1 + BX)}$$

where $X = \Delta R_G / R_G$, $V(t)$ = signal voltage, E_0 = supply voltage, and

$$A = \frac{R_2 R_T R_G}{[2R_1 R_2 + R_3(2R_1 + 2R_2)] [R_2 + R_3 + 2R_T]}$$

$$B = \frac{R_G(2R_1 + 2R_2)(R_3 + R_T) + R_2 R_G(2R_1 + R_2)}{[2R_1 R_2 + R_3(2R_1 + 2R_2)] [R_2 + R_3 + 2R_T]}$$

Note that the initial resistance R_3 of the signal portion of the bridge is not the initial gage resistance R_G because the signal cable and gage leads may introduce some additional series resistance ($R_L = 0.5 \Omega$). When a 50- Ω Manganin gage is used, the output sensitivity is ~ 0.3 V/GPa.

One of the problems in using Manganin gages is gage calibration. Experience at Los Alamos has shown that there is no unique calibration for Manganin [Wackerle, Johnson and Halleck (1975)]. Different encapsulations will generally yield different calibration curves, which explains the variety of calibration curves in this compendium even though, in some cases, the same supplier was used. The estimated precision of these calibrations is 5%, which could be improved by designing self-calibrating shots in which certain features of the wave profile are known. Another complicating feature of the Manganin gage is that the release calibration curve differs from the loading curve [Steinberg and Banner (1979), Morris (1981)]. Steinberg and Banner have measured 10% hysteresis in unloading when the gage was encapsulated between 0.025-mm-thick Kapton layers. A 30% hysteresis was observed by Morris (1981) when a bare gage was encapsulated between single-crystal corundum substrates. No correction to the unloading portion of the wave profiles presented here accounts for this hysteresis.

When Manganin gages are embedded in insulators, the response time to come into equilibrium with their surroundings can be as fast as 10-20 ns. However, when the gages are used in a conductor, the gage has to be encapsulated. Kapton is used commonly for this purpose. In this environment the response time for the gage package is increased considerably. The equilibration time is a function of the gage-package thickness and the impedance mismatch between the target and the encapsulating material. Response times of 100 ns in this configuration are not unusual.

QUARTZ GAGE

The piezoelectric response of crystalline quartz has been used in various ways for pressure measurements. Here, the term quartz gage refers explicitly to the quartz gage developed by Graham and his coworkers [(1965) and (1970)] for measuring interface pressures in one-dimensional shock configurations. Such a gage is simply a disk of synthetic x-cut quartz in contact with a shock-loaded sample. The stress wave transmitted into the quartz element induces a dielectric polarization generating a current approximately proportional to the instantaneous difference in stress at the gage faces. Pressure histories of sample-gage interface are obtained during the stress wave transit time through the gage element, typically 1-2 μ s. The dynamic elastic limit of x-cut quartz imposes a 6-GPa useful upper pressure limit for these gages, and they are most accurate when used below 4-GPa pressure.

The quartz gage experiments in these data used the front-back configuration (Fig. 6). [See Wackerle, Johnson, and Halleck (1975); and Halpin, Jones, and Graham (1963)]. With this configuration, the front, or projectile gage determines the pressure history in the sample at the impact face. The pressure history measured at the back interface is a reflected-wave state in the sample. In addition to the pressure histories, the shock transit time through the sample, and thus an average shock velocity, is obtained by relating the start times of the two gage signals through a common fiducial.

Generally, the quartz gages were used in the condition received from the manufacturer. Specifications on the crystals are those developed at Sandia National Laboratories, Albuquerque, and approach those detailed in Ingram and Graham (1970). The gages were used in either the shunted guard ring or the grounded guard ring geometry (Fig. 7) with the latter being the most commonly used configuration. The quartz gage calibration for the reported wave profiles is detailed by Wackerle, Johnson, and Halleck (1975). Briefly stated, at pressures below 4.1 GPa, the piezoelectric coefficient of Graham, Neilson, and Benedick (1965) and of Ingram and Graham (1970) was used; above 4.1 GPa, the piezoelectric coefficient of Graham and Ingram (1969) was applied. To account for the current increases for time in a step-function loading of the quartz gage, a deconvolution technique was used with the field-fringe correction similar to that described by Bickle, Reed, and Keltner (1971). The precision of the quartz gage profiles is estimated to be 2-3%. Intrinsically, the quartz gage response time is subnanosecond but time resolution is usually limited by the nonplanarity of impact.

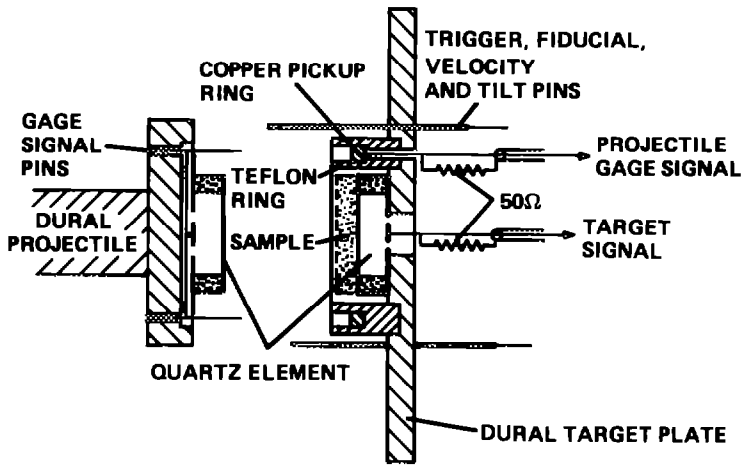

Fig. 6. Quartz-gage front-back experimental assembly. A system with grounded guard ring gages is shown.

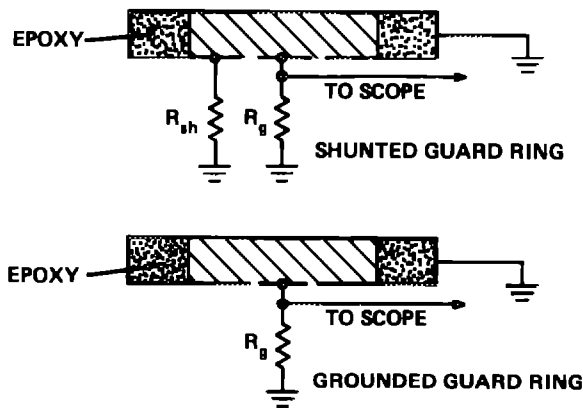

Fig. 7. Quartz-gage guard ring configurations. Heavy lines indicate conducting surfaces. R_g is usually 50Ω and R_{gh}/R_g is properly equal to electrode area/guard ring area.

ELEMENTS

TARGET

Material: Beryllium

Experiment type: Free-surface capacitor

Experimenter: J. W. Taylor

Reference: J. W. Taylor (1968)

Shot no.: 56-65-358 **Date:** August 11, 1965

Thickness: 25.4 mm **Diameter:** 153 mm

IMPACTOR

Beryllium, 12.7 mm thick, backed with low-density polyurethane foam, mounted on 165-mm-diam aluminum alloy projectile

Impact velocity: 0.507 mm/ μ s

TRANSDUCER

Free-surface capacitor

Time: Relative

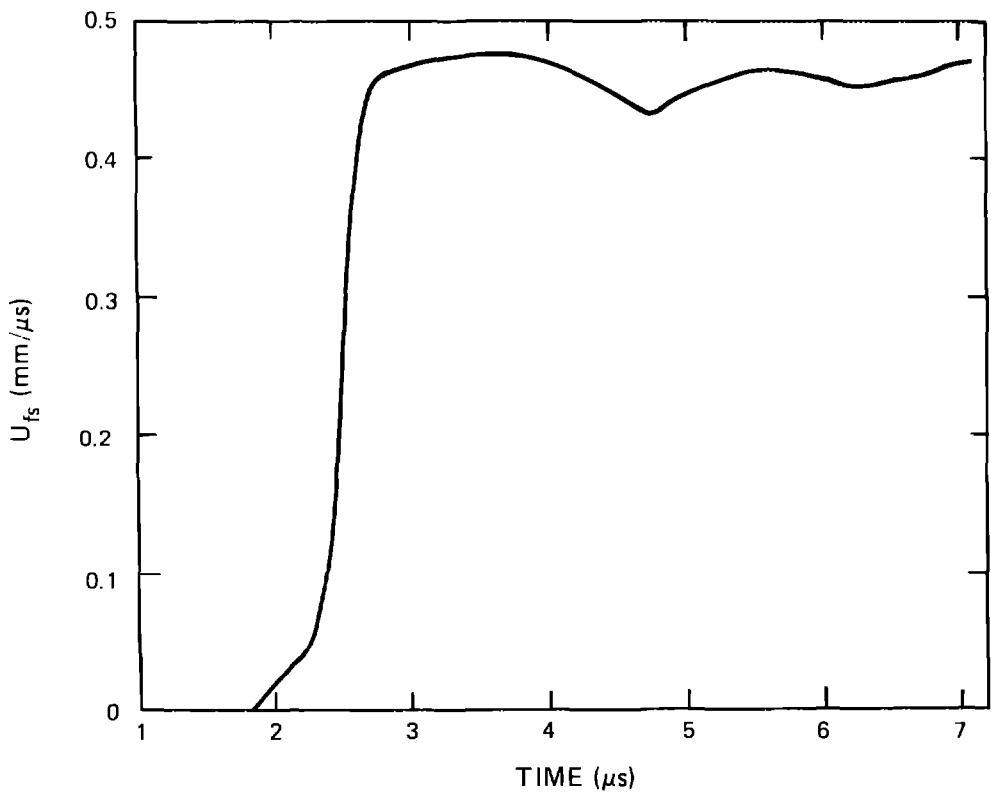

TARGET **Material:** Beryllium, single crystal, perpendicular to C-axis
Experiment type: Free-surface capacitor
Experimenter: J. W. Taylor
Reference: J. W. Taylor (1968)
Shot no.: 56-63-221 **Date:** April 25, 1963
Density: 1.848 g/cm³

IMPACTOR Steel, 6.35 mm thick, mounted on 51-mm-diam aluminum alloy projectile

TRANSDUCER Free-surface capacitor
Time: Relative

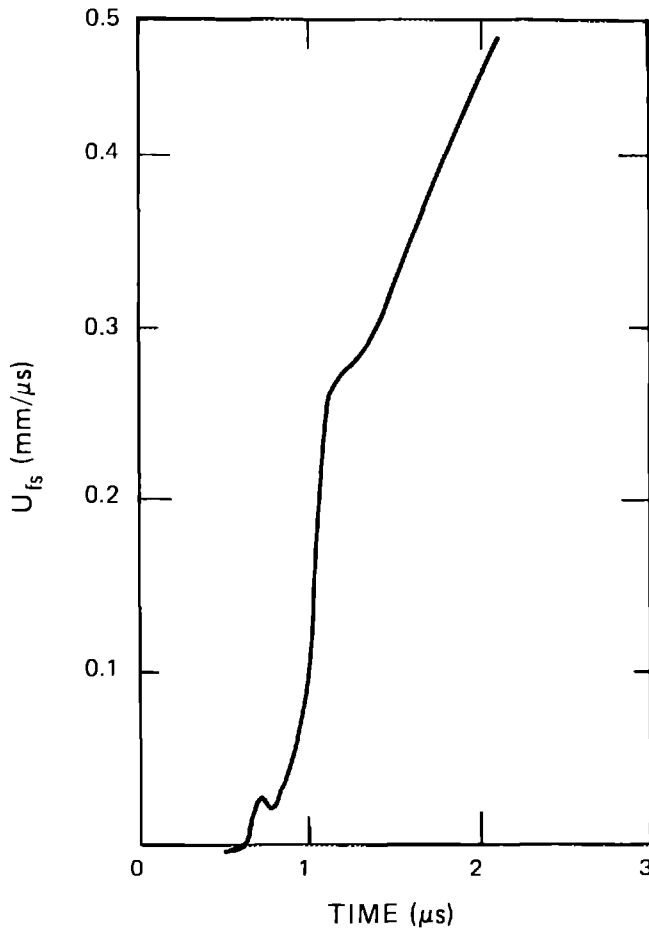

TARGET

Material: Beryllium, single crystal, parallel to C-axis

Experiment type: Free-surface capacitor

Experimenter: J. W. Taylor

Reference: J. W. Taylor (1968)

Shot no.: 56-63-222 **Date:** April 25, 1963

Density: 1.848 g/cm³

IMPACTOR

Steel, 6.35 mm thick, mounted on 51-mm-diam aluminum alloy projectile

TRANSDUCER

Free-surface capacitor

Time: Relative

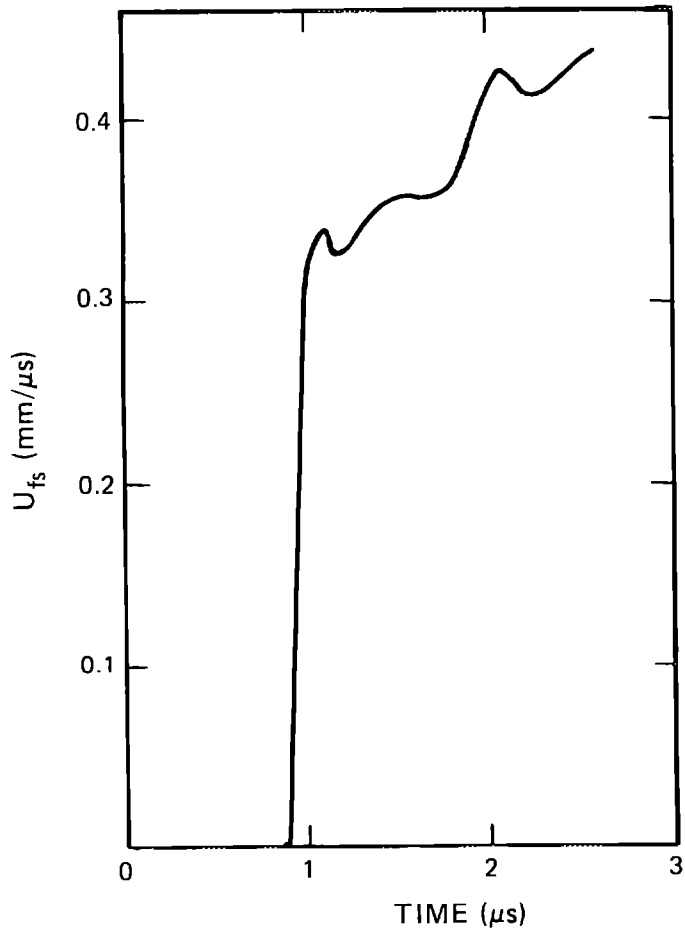

TARGET **Material:** Beryllium
 Experiment type: Free-surface capacitor
 Experimenter: J. W. Taylor
 Shot no.: 56-67-428 **Date:** March 29, 1967
 Thickness: 12.70 mm **Diameter:** 38.1 mm

IMPACTOR Beryllium, 1.59 mm thick, backed with low-density polyurethane foam, mounted on 51-mm-diam aluminum alloy projectile
 Impact velocity: 0.410 mm/ μ s

TRANSDUCER Free-surface capacitor
 Time: Relative

NOTES Shots 56-67-428, 56-67-429, and 56-67-430 are a series of overtaking unloading wave profiles with varied driver thickness at constant impact stress.

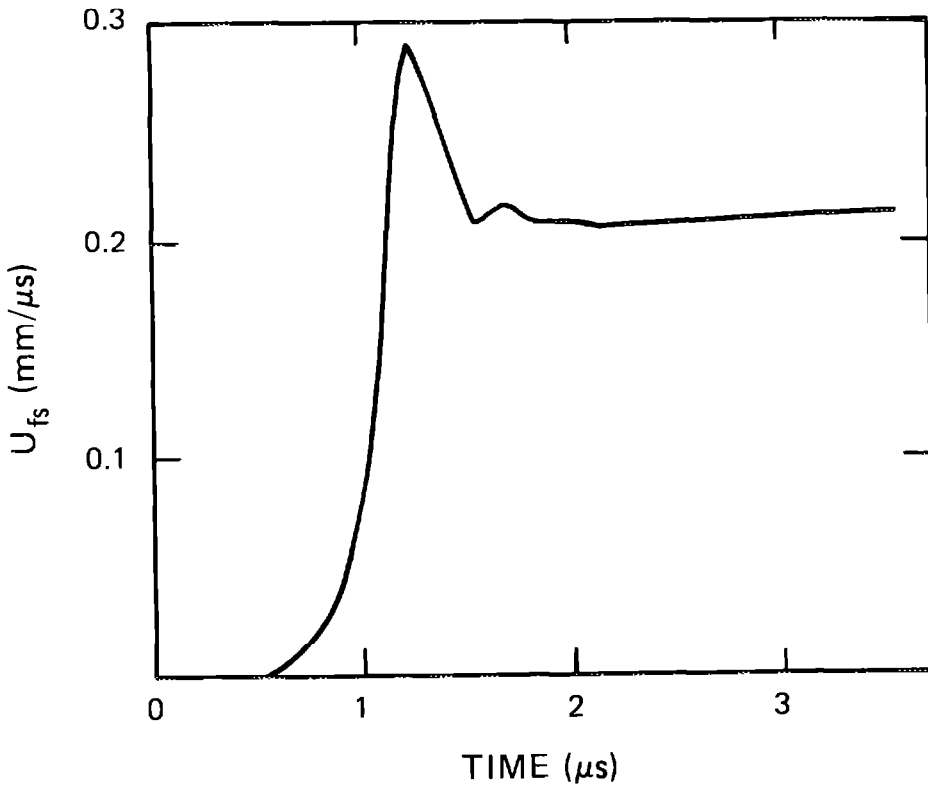

TARGET

Material: Beryllium
Experiment type: Free-surface capacitor
Experimenter: J. W. Taylor
Shot no.: 56-67-429 **Date:** March 29, 1967
Thickness: 12.7 mm **Diameter:** 38.1 mm

IMPACTOR

Beryllium, 3.18 mm thick, backed with low-density polyurethane foam, mounted on 51-mm-diam aluminum alloy projectile
Impact velocity: 0.410 mm/ μ s

TRANSDUCER

Free-surface capacitor
Time: Relative

NOTES

Shots 56-67-428, 56-67-429, and 56-67-430 are a series of overtaking unloading wave profiles with varied driver thickness at constant impact stress.

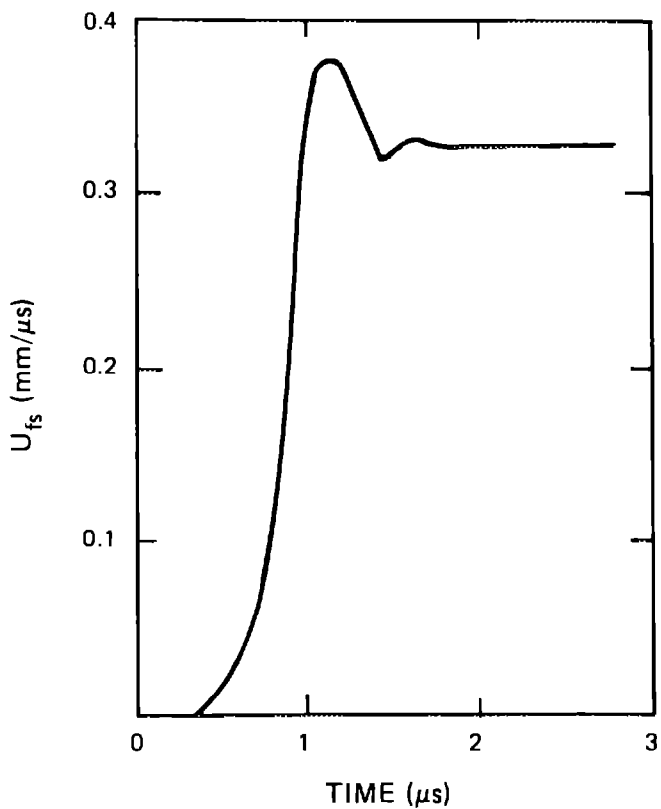

TARGET

Material: Beryllium
Experiment type: Free-surface capacitor
Experimenter: J. W. Taylor
Reference: J. W. Taylor (1968)
Shot no.: 56-67-430 **Date:** March 30, 1967
Thickness: 12.70 mm **Diameter:** 38.1 mm

IMPACTOR

Beryllium, 6.35 mm thick, backed with low-density polyurethane foam, mounted on 51-mm-diam aluminum alloy projectile
Impact velocity: 0.410 mm/ μ s

TRANSDUCER

Free-surface capacitor
Time: Relative

NOTES

Shots 56-67-428, 56-67-429 and 56-67-430 are a series of overtaking unloading wave profiles with varied driver thickness at constant impact stress.

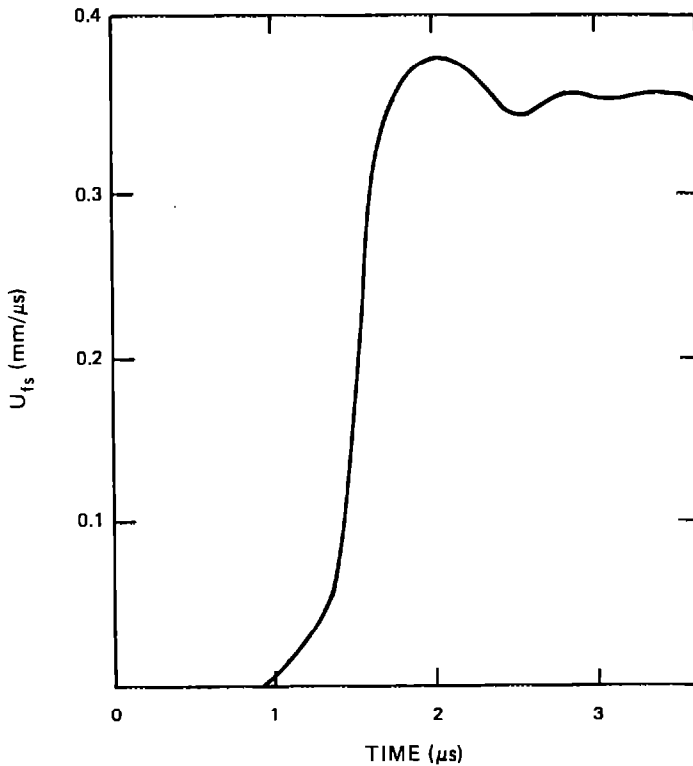

TARGET

Material: Boron

Experiment type: Free-surface capacitor

Experimenter: J. W. Hopson

Shot no.: 80802 **Date:** July 17, 1968

HE SHOT GEOMETRY

102-mm baratol/2024 aluminum base plate/6.34 mm boron

SHOT COMPONENTS

Boron

Density: 2.33 g/cm³

$C_L = 13.90$ mm/ μ s $C_S = 9.00$ mm/ μ s

TRANSDUCER

Free-surface capacitor

Time: Relative

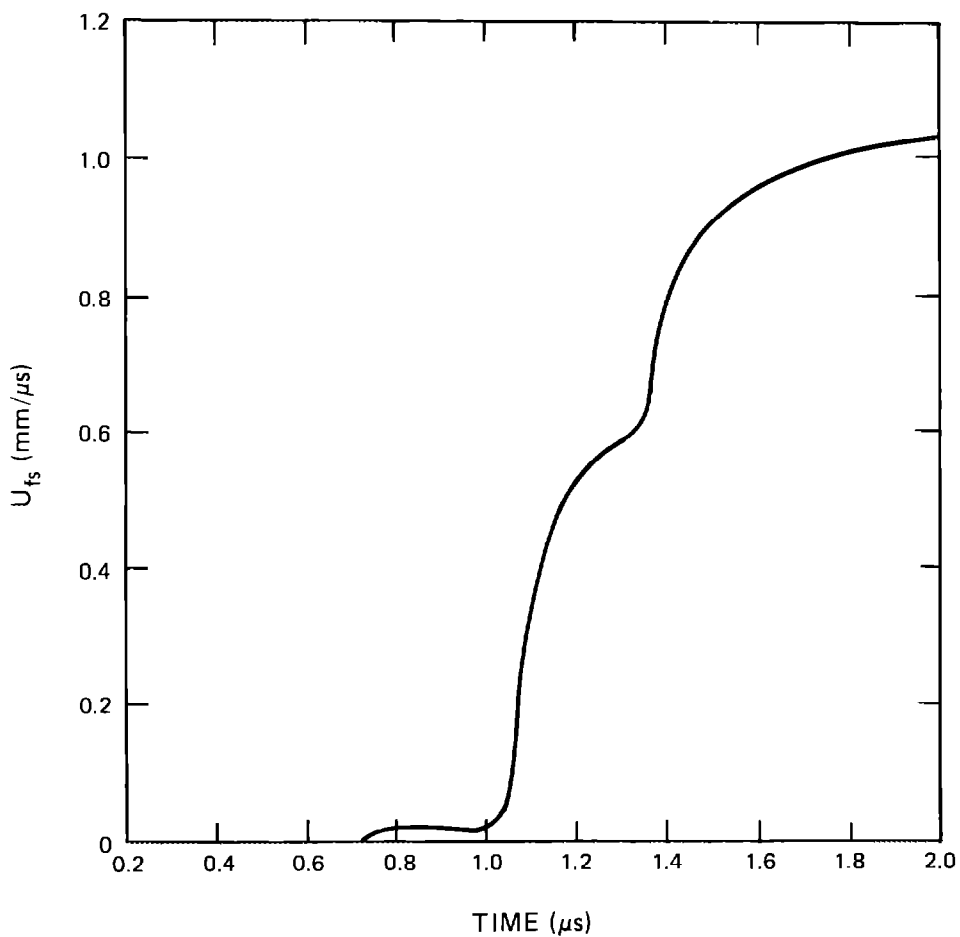

TARGET

Material: Carbon, $\rho = 0.315 \text{ g/cm}^3$
Experiment type: ASM probe
Experimenters: J. N. Fritz and J. A. Morgan
Shot no.: M 51 **Date:** September 21, 1971

HE SHOT GEOMETRY

P-081 lens/102 mm PBX 9404/12.76 mm 2024 aluminum//
9.65 mm carbon/5.00 mm air//

SHOT COMPONENTS

Carbon
Density: 0.315 g/cm^3
2024 aluminum
Density: 2.785 g/cm^3
 $C_L = 6.36 \text{ mm}/\mu\text{s}$ $C_S = 3.16 \text{ mm}/\mu\text{s}$

TRANSDUCER

ASM probe
Coil radius: 28.64 mm **Initial coil spacing:** 14.65 mm

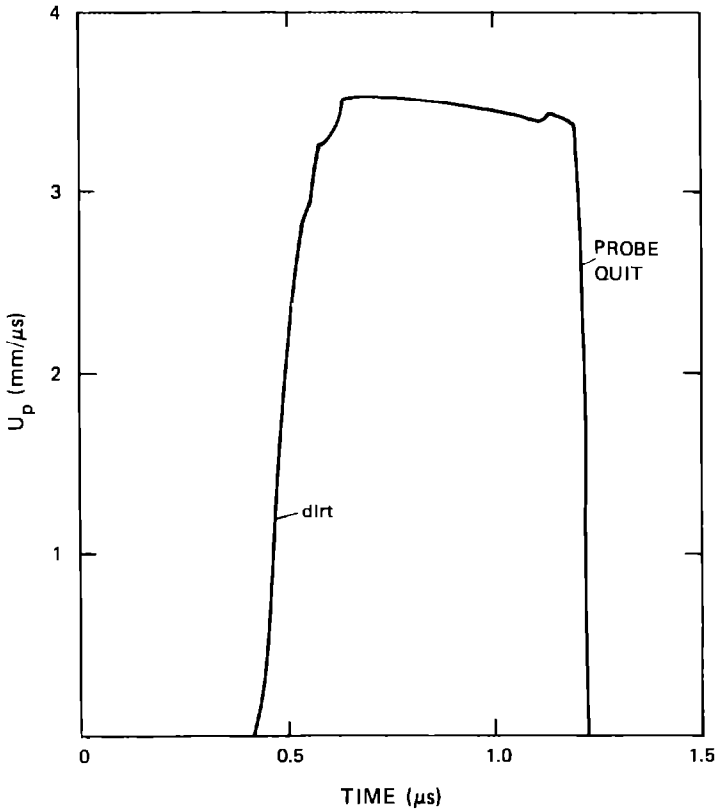

TARGET

Material: Carbon, $\rho = 0.326 \text{ g/cm}^3$

Experiment type: ASM probe

Experimenters: J. N. Fritz and J. A. Morgan

Shot no.: M 52 **Date:** September 27, 1971

HE SHOT GEOMETRY

P-081 lens/102 mm PBX 9404/12.78 mm 2024 aluminum//
12.75 mm carbon/4.96 mm air//

SHOT COMPONENTS

Carbon

Density: 0.326 g/cm^3

2024 aluminum

Density: 2.785 g/cm^3

$C_L = 6.36 \text{ mm}/\mu\text{s}$ $C_S = 3.16 \text{ mm}/\mu\text{s}$

PBX 9404

Density: 1.830 g/cm^3

$C_L = 2.90 \text{ mm}/\mu\text{s}$ $C_S = 1.57 \text{ mm}/\mu\text{s}$

TRANSDUCER

ASM probe

Coil radius: 28.64 mm **Initial coil spacing:** 17.71 mm

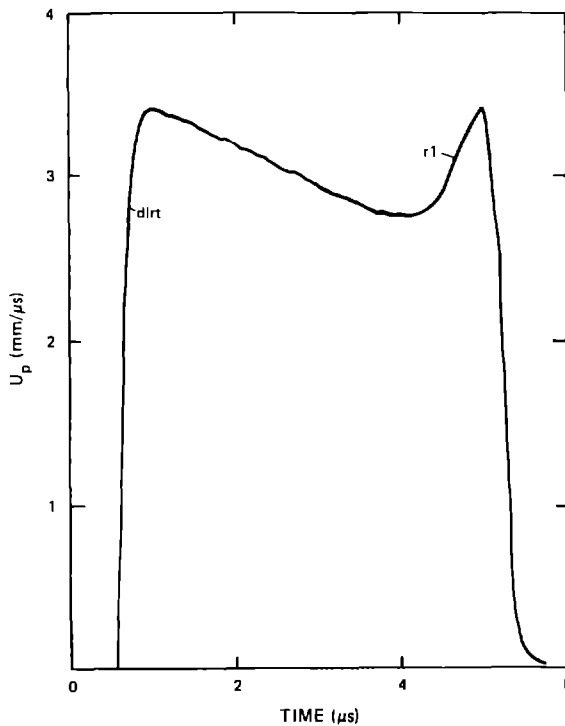

TARGET

Material: Carbon, $\rho = 0.3247 \text{ g/cm}^3$
Experiment type: ASM probe
Experimenters: J. N. Fritz and J. A. Morgan
Shot no.: M 53 **Date:** December 16, 1971

HE SHOT GEOMETRY

P-120 lens/152 mm PBX 9404/12.75 mm 2024 aluminum//
6.60 mm carbon/f- 6.37 mm corundum mixture*//

SHOT COMPONENTS

Carbon
Density: 0.3247 g/cm^3
2024 aluminum
Density: 2.785 g/cm^3
 $C_L = 6.36 \text{ mm}/\mu\text{s}$ $C_s = 3.16 \text{ mm}/\mu\text{s}$
Corundum mixture*
Density: 3.389 g/cm^3
 $C_L = 8.94 \text{ mm}/\mu\text{s}$ $C_s = 5.25 \text{ mm}/\mu\text{s}$

TRANSDUCER

ASM probe
Coil radius: 28.65 mm **Initial coil spacing:** 12.97 mm

*85.2 wt% Al_2O_3 /9.7 wt% SiO_2 /2.7 wt% MgO /2.4 wt% CaO-BaO

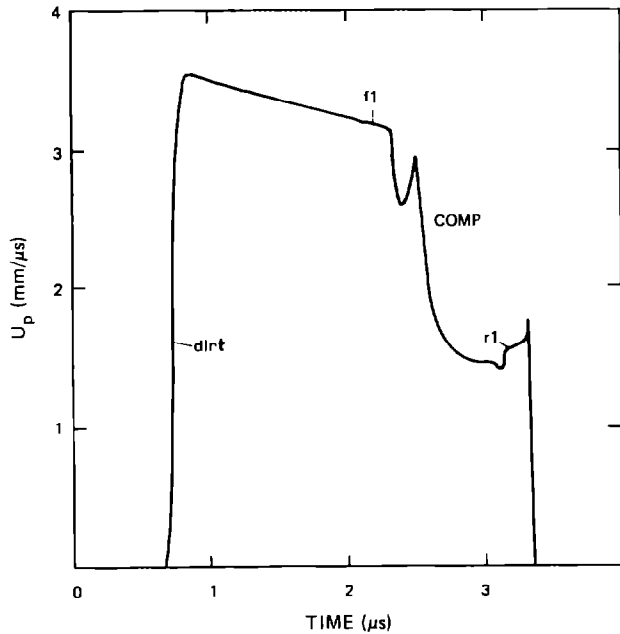

TARGET

Material: Carbon (PT 0178 graphite)
Experiment type: Free-surface capacitor
Experimenter: J. W. Taylor
Reference: R. G. McQueen, S. P. Marsh, J. W. Taylor, J. N. Fritz, and W. J. Carter (1970)
Shot no.: 56-65-365 **Date:** November 19, 1965
Thickness: 6.35 mm **Diameter:** 38.1 mm
Density: 1.55 g/cm³

IMPACTOR

PT 0178 graphite, 6.35 mm thick, mounted on 51-mm-diam aluminum alloy projectile
Impact velocity: 0.290 mm/ μ s

TRANSDUCER

Free-surface capacitor
Time: Relative

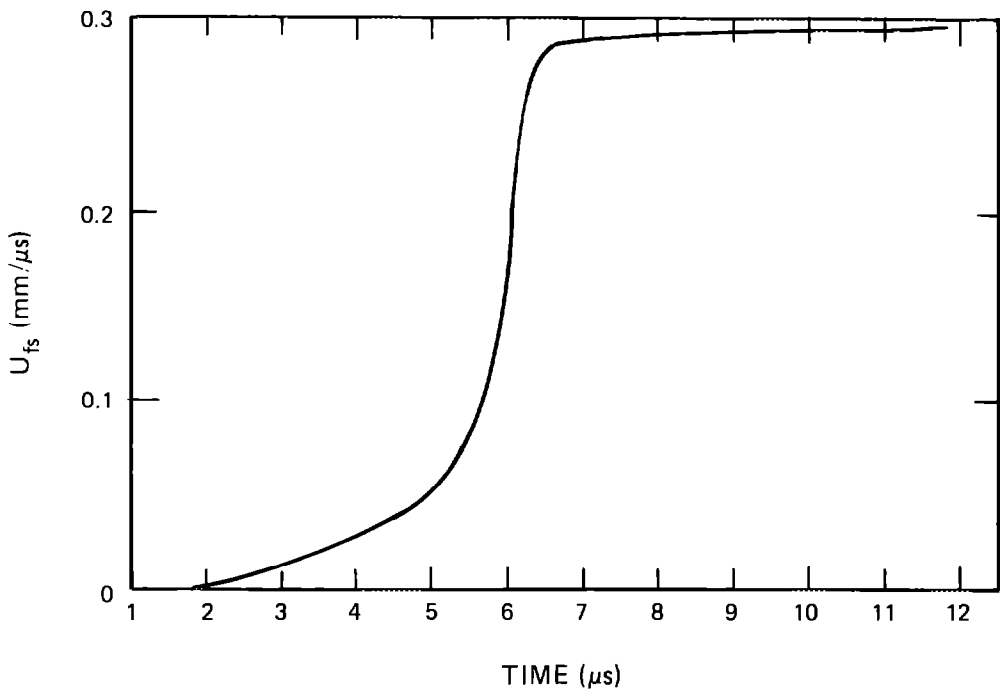

TARGET

Material: Germanium [100] direction
Experiment type: Free-surface capacitor
Experimenter: J. W. Taylor
Reference: R. G. McQueen, S. P. Marsh, J. W. Taylor, J. N. Fritz, and W. J. Carter (1970)
Shot no.: 56-65-348 **Date:** June 21, 1965
Thickness: 7.70 mm
Density: 5.323 g/cm³

IMPACTOR

Tungsten carbide backed by 2024 aluminum, mounted on 51-mm-diam aluminum alloy projectile

TRANSDUCER

Free-surface capacitor
Time: Relative

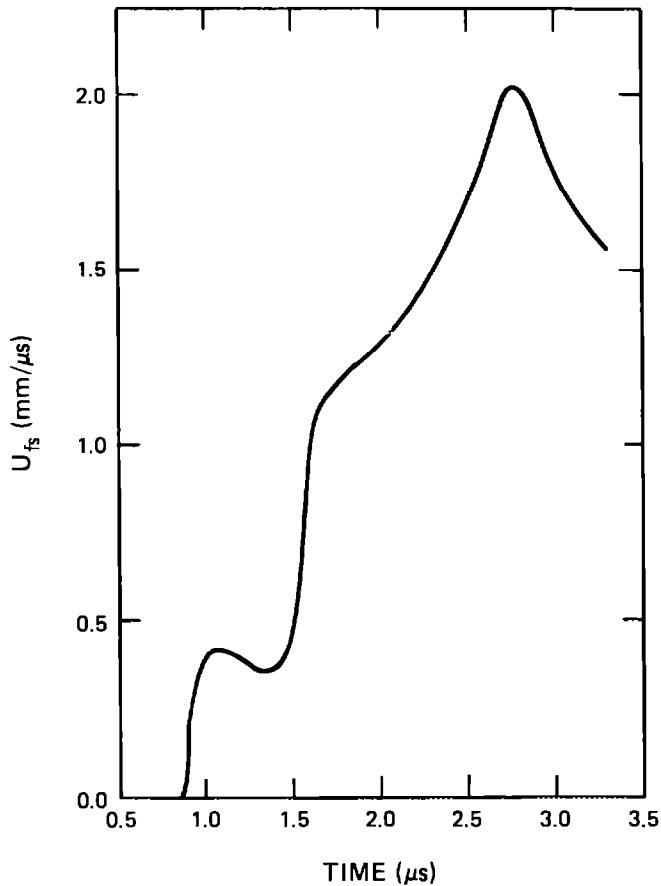

TARGET

Material: Armco iron
Experiment type: Free-surface capacitor
Experimenter: J. W. Taylor
Shot no.: 56-64-328 **Date:** September 3, 1964
Thickness: 25.40 mm **Diameter:** 152.4 mm
Density: 7.87 g/cm³
C_L = 5.94 mm/μs **C_S** = 3.26 mm/μs

IMPACTOR

Armco iron mounted on 165-mm-diam aluminum alloy projectile
Impact velocity: 0.977 mm/μs

TRANSDUCER

Free-surface capacitor
Time: Relative

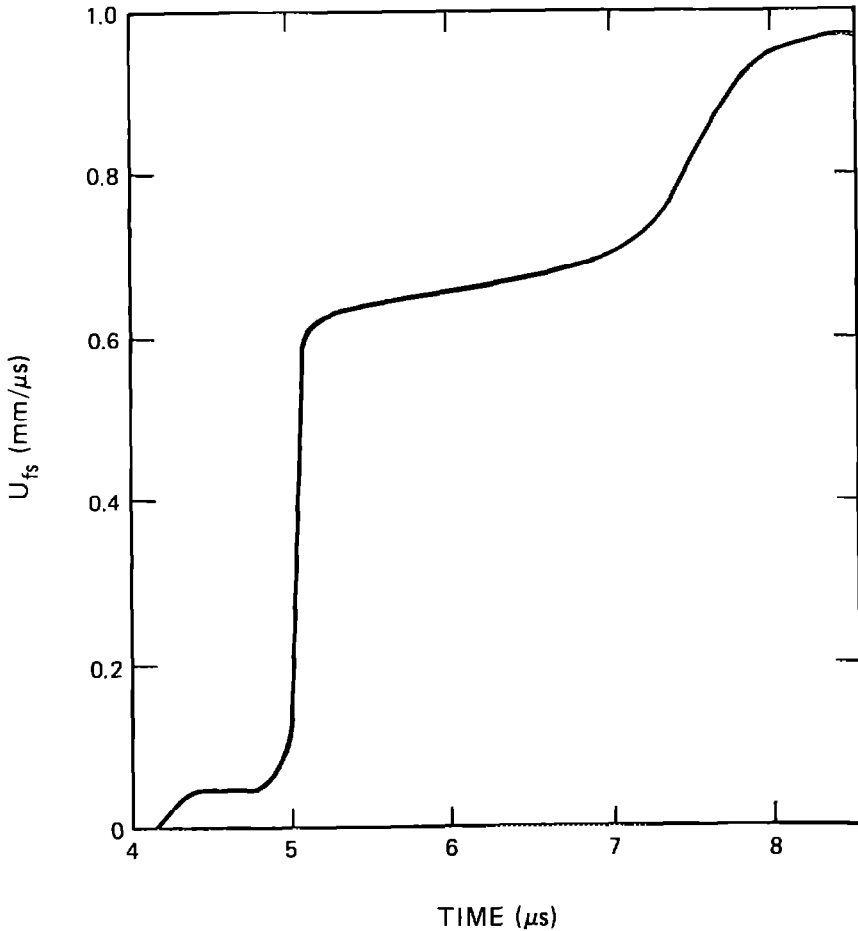

TARGET

Material: Armco iron
Experiment type: Free-surface capacitor
Experimenters: J. W. Taylor and M. H. Rice
Reference: J. W. Taylor and M. H. Rice (1963)
Shot no.: 56-60-50 **Date:** November 4, 1960
Thickness: 25.4 mm **Diameter:** 153 mm
Density: 7.87 g/cm³
C_L = 5.94 mm/μs **C_s =** 3.26 mm/μs
Heat treatment: Annealed

IMPACTOR

Armco iron, 25.4 mm thick, mounted on 165-mm-diam aluminum alloy projectile
Impact velocity: 0.372 mm/μs

TRANSDUCER

Free-surface capacitor
Time after impact

NOTES

Shots 56-60-50, 56-60-55, 56-61-66, and 56-61-99 are a series with varied target thickness.

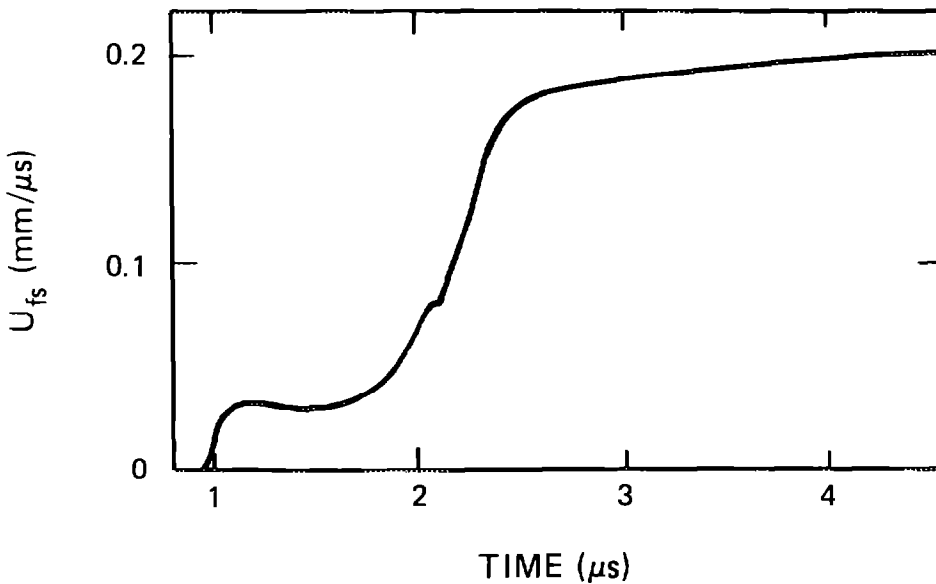

TARGET

Material: Armco iron
Experiment type: Free-surface capacitor
Experimenters: J. W. Taylor and M. H. Rice
Reference: J. W. Taylor and M. H. Rice (1963)
Shot no.: 56-60-55 **Date:** December 22, 1960
Thickness: 12.70 mm **Diameter:** 153 mm
Density: 7.87 g/cm³
C_L = 5.94 mm/μs **C_S = 3.26 mm/μs**
Heat treatment: Annealed

IMPACTOR

Armco iron, 12.70 mm thick, mounted on 165-mm-diam aluminum alloy projectile
Impact velocity: 0.164 mm/μs

TRANSDUCER

Free-surface capacitor
Time after impact

NOTES

Shots 56-60-50, 56-60-55, 56-61-66, and 56-61-99 are a series with varied target thickness.

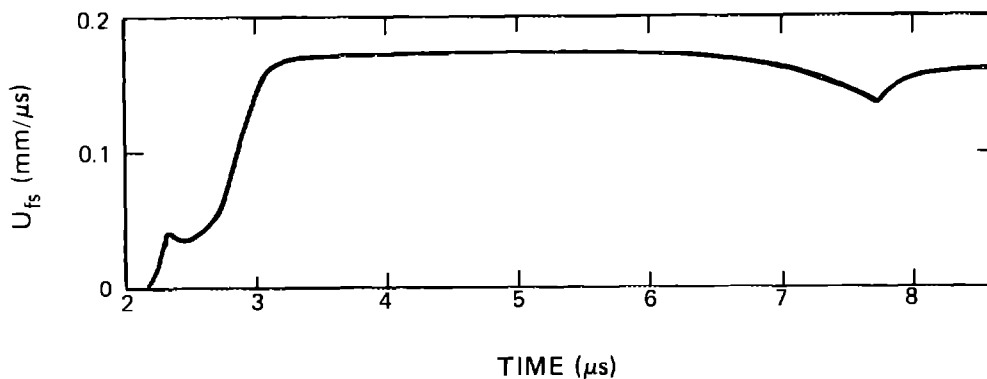

TARGET

Material: Armco iron
Experiment type: Free-surface capacitor
Experimenters: J. W. Taylor and M. H. Rice
Reference: J. W. Taylor and M. H. Rice (1963)
Shot no.: 56-61-66 **Date:** March 1, 1961
Thickness: 50.80 mm **Diameter:** 153 mm
Density: 7.87 g/cm³
C_L = 5.94 mm/μs C_g = 3.26 mm/μs
Heat treatment: Annealed

IMPACTOR

Armco iron, 25.4 mm thick, mounted on 165-mm-diam aluminum alloy projectile
Impact velocity: 0.170 mm/μs

TRANSDUCER

Free-surface capacitor
Time after impact

NOTES

Shots 56-60-50, 56-60-55, 56-61-66, and 56-61-99 are a series with varied target thickness.

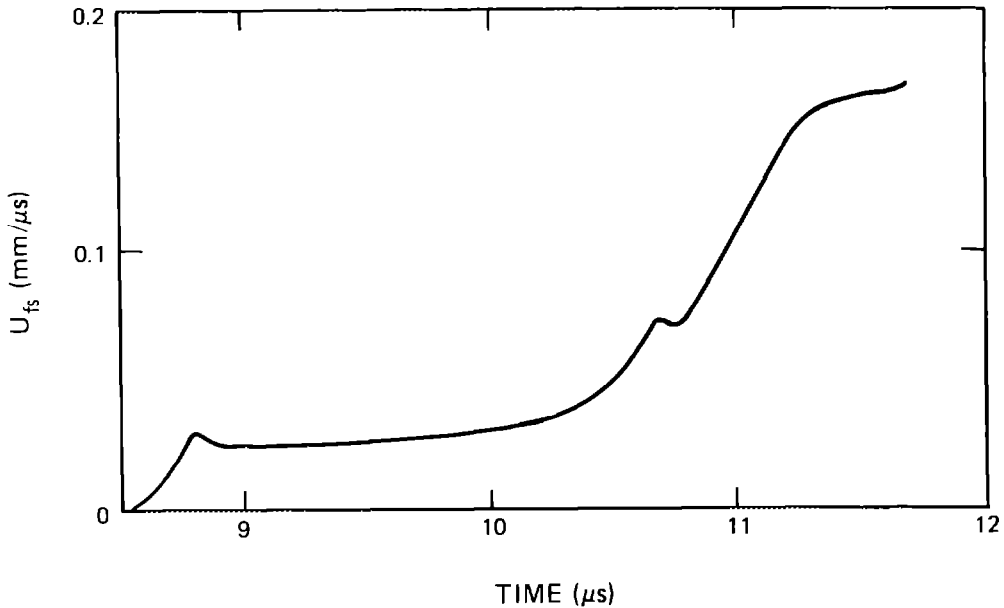

TARGET

Material: Armco iron
Experiment type: Free-surface capacitor
Experimenters: J. W. Taylor and M. H. Rice
Reference: J. W. Taylor and M. H. Rice (1963)
Shot no.: 56-61-99 **Date:** September 19, 1961
Thickness: 6.35 mm **Diameter:** 153 mm
Density: 7.87 g/cm³
 $C_L = 5.94$ mm/ μ s $C_S = 3.26$ mm/ μ s
Heat treatment: Annealed

IMPACTOR

Armco iron, 3.18 mm thick, mounted on 165-mm-diam aluminum alloy projectile
Impact velocity: 0.157 mm/ μ s

TRANSDUCER

Free-surface capacitor
Time after impact

NOTES

Shots 56-60-50, 56-60-55, 56-61-66, and 56-61-99 are a series with varied target thickness.

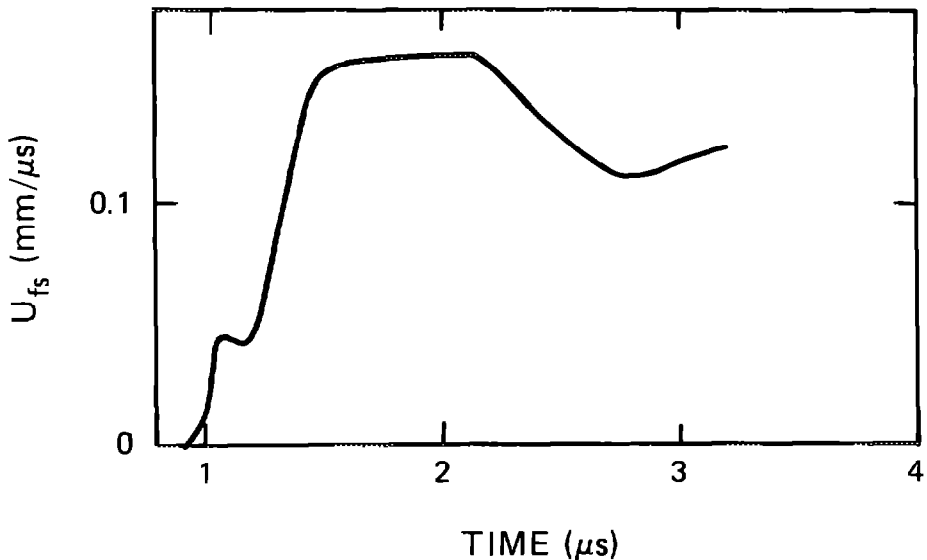

TARGET **Material:** Armco iron preshocked to 80 GPa
Experiment type: Free-surface capacitor
Experimenters: J. W. Taylor
Shot no.: 56-63-176 **Date:** January 23, 1963
Density: 7.87 g/cm³
C_L = 5.94 mm/μs **C_S** = 3.26 mm/μs

IMPACTOR Iron, 6.35 mm thick, mounted on aluminum alloy projectile

TRANSDUCER Free-surface capacitor
Time: Relative

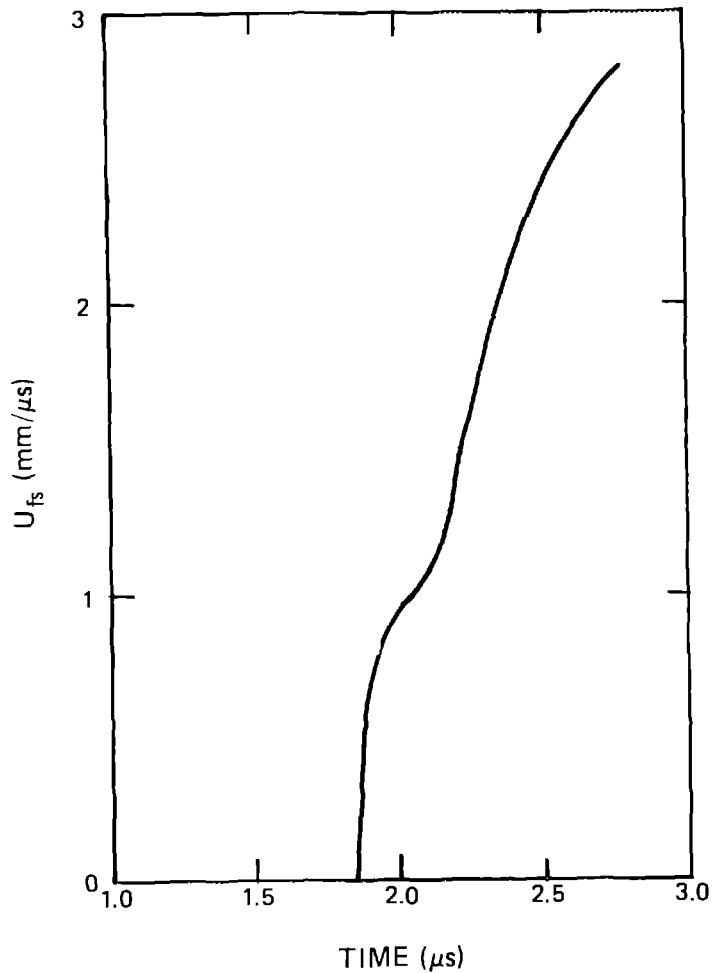

TARGET

Material: Armco iron
Experiment type: Free-surface capacitor
Experimenters: J. W. Taylor and M. H. Rice
Shot no.: 56-61-91 **Date:** August 18, 1961
Thickness: 12.70 mm **Diameter:** 152.4 mm
Density: 7.87 g/cm³
C_L = 5.94 mm/μs **C_g =** 3.26 mm/μs
Heat treatment: Annealed

IMPACTOR

Armco iron, 6.35 mm thick, backed with low-density polyurethane foam, mounted on 165-mm-diam aluminum alloy projectile
Impact velocity: 0.361 mm/μs

TRANSDUCER

Free-surface capacitor
Time: Relative

NOTES

Shots 56-61-91, 56-61-92, and 56-61-94 are a series of wave profiles with varied impact stress.

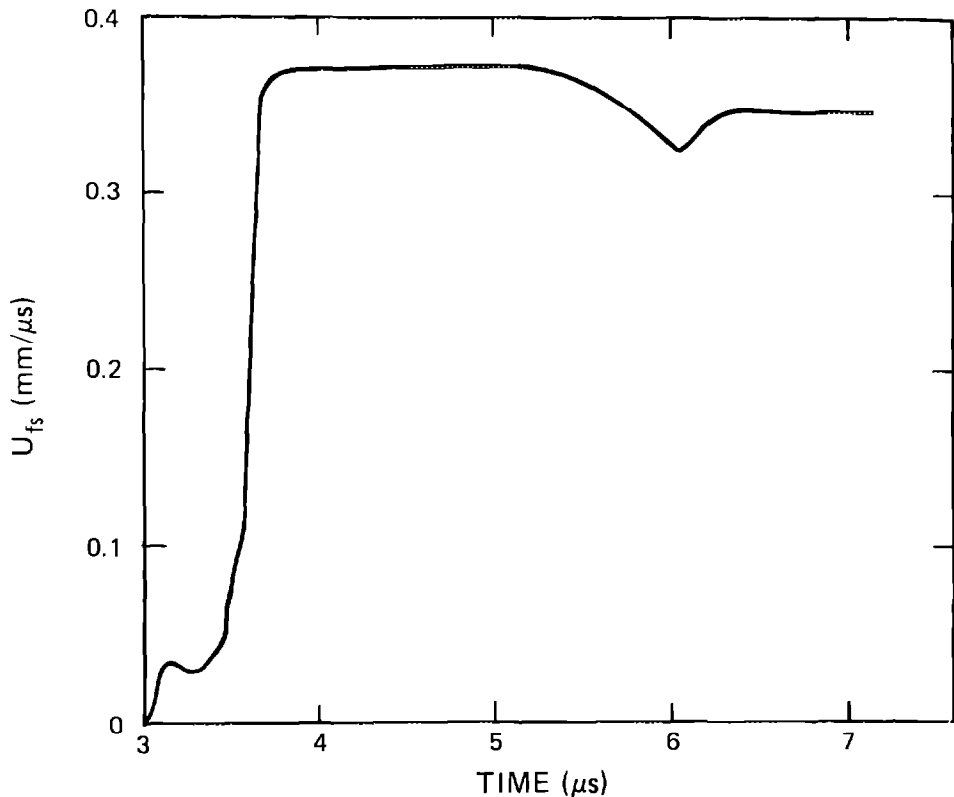

TARGET

Material: Armco iron
Experiment type: Free-surface capacitor
Experimenters: J. W. Taylor and M. H. Rice
Shot no.: 56-61-92 Date: August 21, 1961
Thickness: 12.70 mm Diameter: 152.4 mm
Density: 7.87 g/cm³
 $C_L = 5.94$ mm/ μ s $C_S = 3.26$ mm/ μ s
Heat treatment: Annealed

IMPACTOR

Armco iron, 6.35 mm thick, backed with low-density polyurethane foam, mounted on 165-mm-diam aluminum alloy projectile
Impact velocity: 0.064 mm/ μ s

TRANSDUCER

Free-surface capacitor
Time: Relative

NOTES

Shots 56-61-91, 56-61-92, and 56-61-94 are a series of wave profiles with varied impact stress.

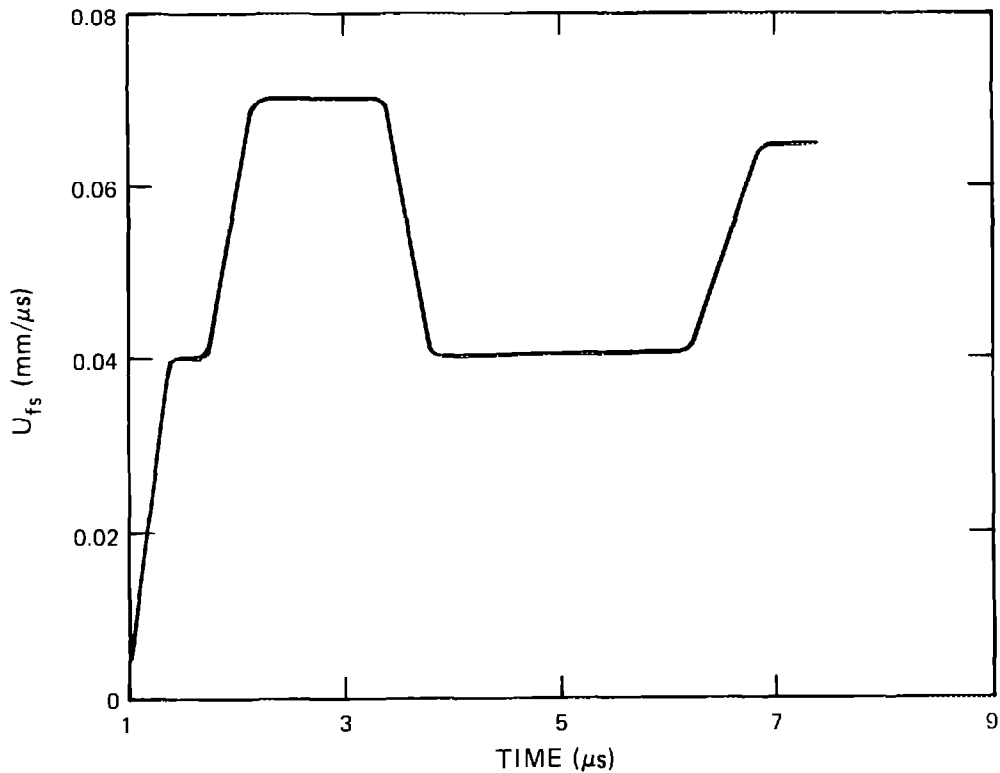

TARGET

Material: Armco iron
Experiment type: Free-surface capacitor
Experimenters: J. W. Taylor and M. H. Rice
Reference: J. W. Taylor and M. H. Rice (1963)
Shot no.: 56-61-94 **Date:** August 28, 1961
Thickness: 12.70 mm **Diameter:** 152.4 mm
Density: 7.87 g/cm³
C_L = 5.94 mm/μs **C_s** = 3.26 mm/μs
Heat treatment: Annealed

IMPACTOR

Armco iron, 6.35 mm thick, backed with low-density polyurethane foam, mounted on 165-mm-diam aluminum alloy projectile
Impact velocity: 0.154 mm/μs

TRANSDUCER

Free-surface capacitor
Time: Relative

NOTES

Shots 56-61-91, 56-61-92, and 56-61-94 are a series of wave profiles with varied impact stress.

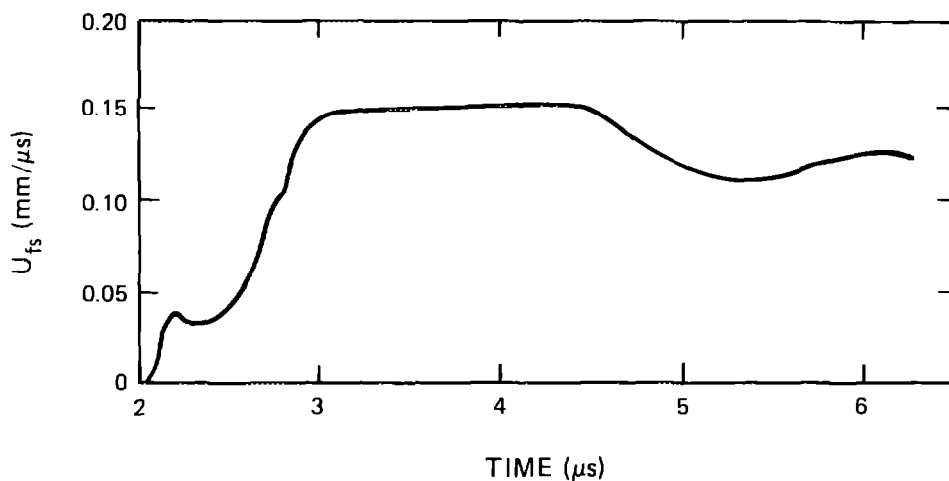

TARGET

Material: Armco iron
Experiment type: Free-surface capacitor
Experimenter: J. W. Taylor
Shot no.: 56-64-327 **Date:** September 3, 1964
Thickness: 9.53 mm
Density: 7.87 g/cm³
C_L = 5.94 mm/μs C_S = 3.26 mm/μs

IMPACTOR

Armco iron, 3.18 mm thick, backed by tungsten, mounted on aluminum alloy projectile
Impact velocity: 0.977 mm/μs

TRANSDUCER

Free-surface capacitor
Time: Relative

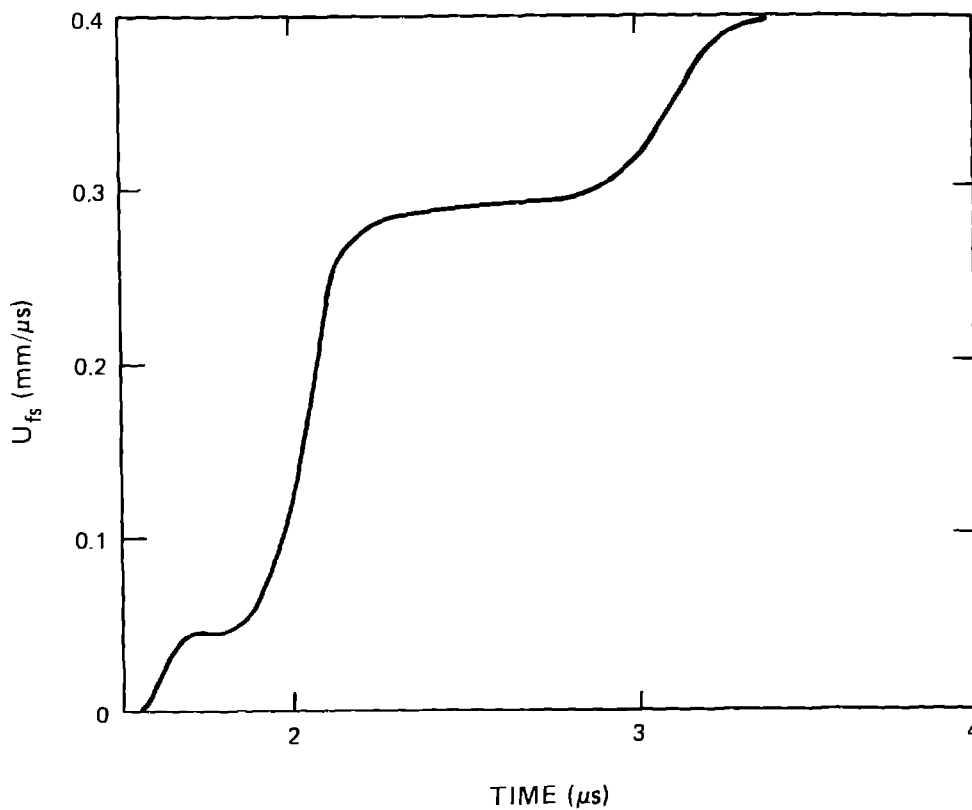

TARGET

Material: Armco iron at 96°C

Experiment type: Free-surface capacitor

Experimenter: J. W. Taylor

Shot no.: 56-65-372 **Date:** March 1, 1965

Thickness: 12.70 mm **Diameter:** 38.1 mm

Density: 7.87 g/cm³

$C_L = 5.94 \text{ mm}/\mu\text{s}$ $C_S = 3.26 \text{ mm}/\mu\text{s}$

IMPACTOR

Steel C-1018, mounted on 51-mm-diam aluminum alloy projectile

TRANSDUCER

Free-surface capacitor

Time: Relative

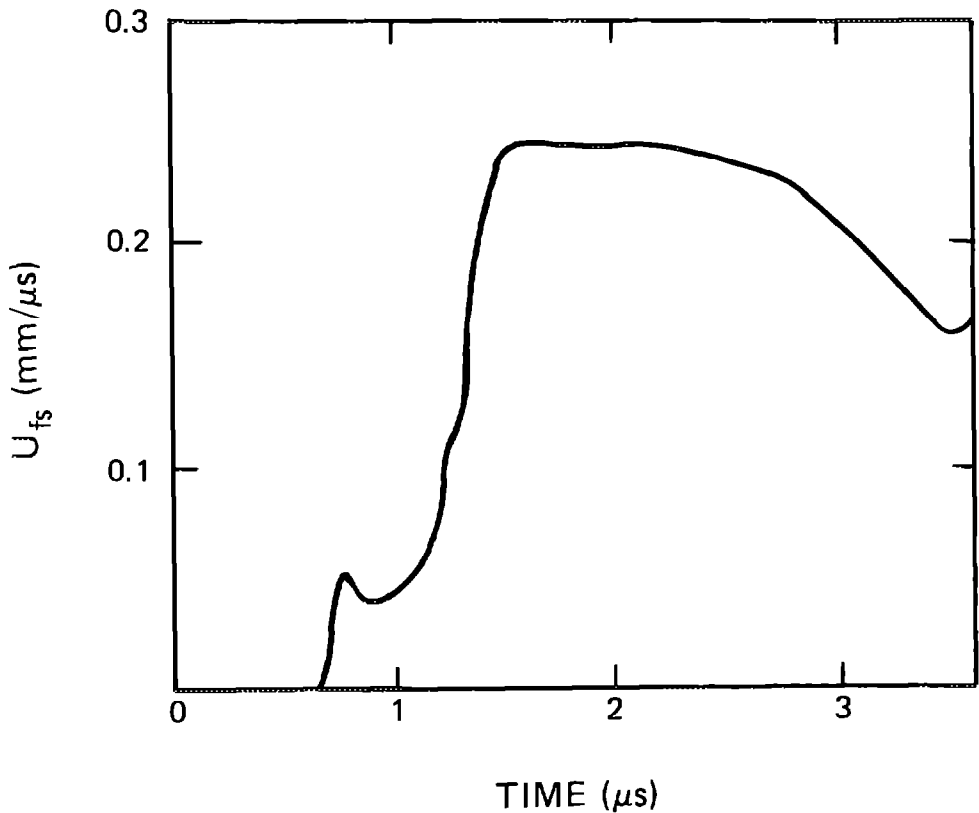

TARGET**Material:** Lead**Experiment type:** Free-surface capacitor**Experimenters:** J. W. Taylor and M. H. Rice**Shot no.:** 56-61-82 **Date:** July 13, 1961**Thickness:** 12.65 mm **Diameter:** 153 mm**Density:** 11.34 g/cm³ $C_L = 2.25 \text{ mm}/\mu\text{s}$ $C_s = 0.89 \text{ mm}/\mu\text{s}$ **IMPACTOR**

Lead mounted on 165-mm-diam aluminum alloy projectile

Impact velocity: 0.116 mm/ μs **TRANSDUCER**

Free-surface capacitor

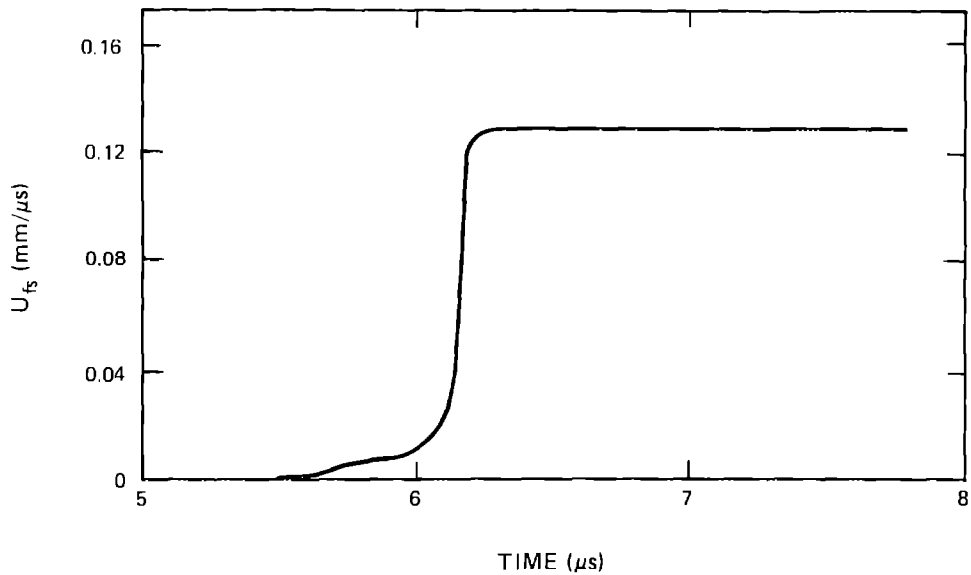
Time: Relative

TARGET**Material:** Mercury**Experiment type:** Free-surface capacitor**Experimenter:** J. W. Taylor**Shot no.:** 56-63-183 **Date:** February 13, 1963**Thickness:** 1.29 mm iron, 6.34 mm mercury**Diameter:** 38.1 mm**Density:** 13.595 g/cm³ $C_L = 1.45 \text{ mm}/\mu\text{s}$ **IMPACTOR**

Cold-rolled steel, 6.35 mm thick, backed with low-density polyurethane foam, mounted on 51-mm-diam aluminum alloy projectile

Impact velocity: 0.257 mm/ μs **TRANSDUCER**

Free-surface capacitor

Time: Relative**NOTES**

The mercury target was supported by 1.29-mm-thick iron at the impact surface.

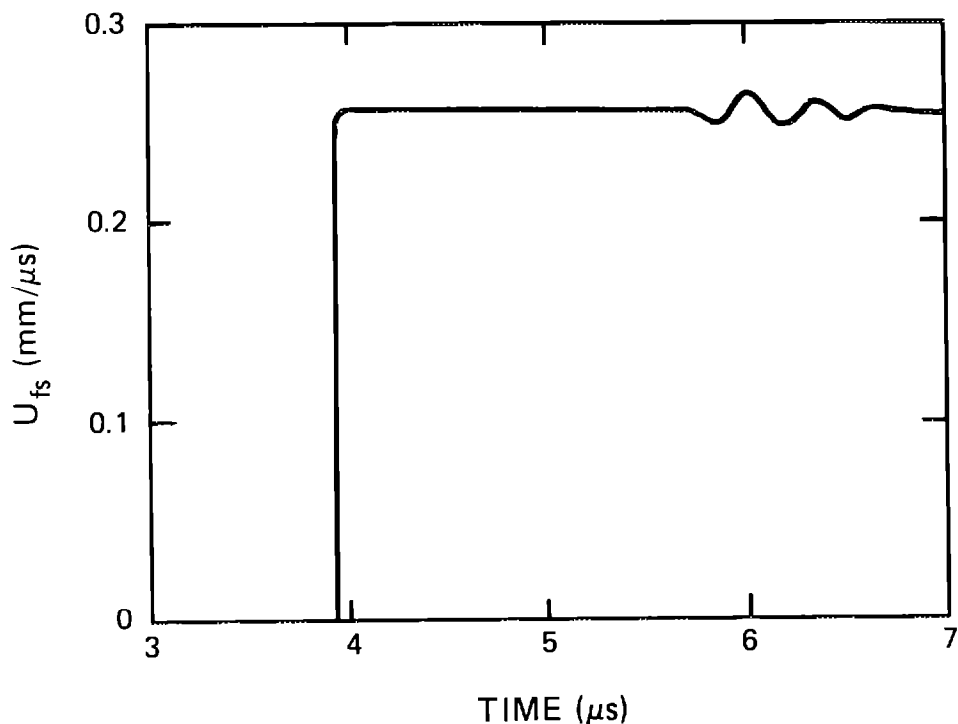

TARGET

Material: Niobium
Experiment type: Free-surface capacitor
Experimenter: J. W. Taylor
Shot no.: 56-63-229 **Date:** May 16, 1963
Thickness: 12.07 mm **Diameter:** 38.1 mm
Density: 8.68 g/cm³
C_L = 5.03 mm/μs **C_g** = 2.11 mm/μs

IMPACTOR

Iron, 6.35 mm thick, mounted on 51-mm-diam aluminum alloy projectile
Impact velocity: 0.199 mm/μs

TRANSDUCER

Free-surface capacitor
Time: Relative

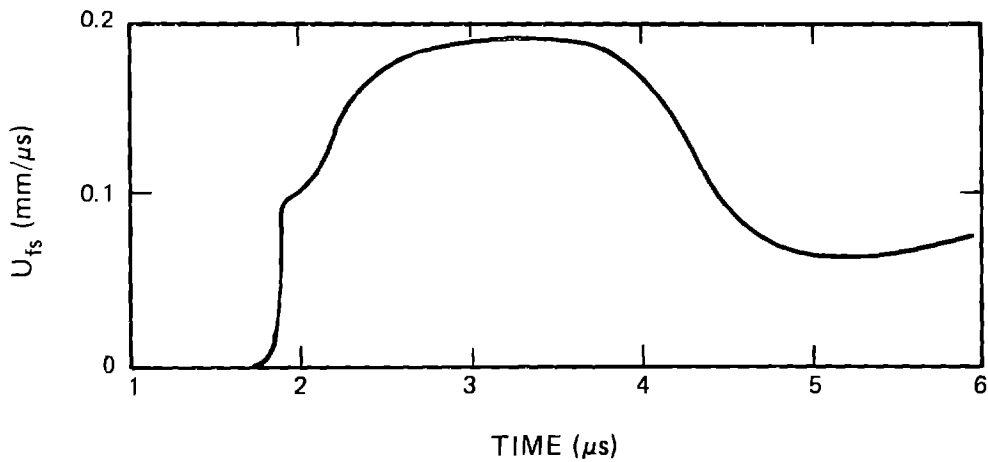

TARGET

Material: Silicon [100] direction
Experiment type: Free-surface capacitor
Experimenter: J. W. Hopson
Shot no.: 80101 **Date:** August 7, 1968

HE SHOT GEOMETRY

P-080 lens/127 mm Comp B/4.83 mm stainless steel/
25.4 mm free run/12.7 mm 2024 aluminum base plate/
7.62 mm silicon [100]

SHOT COMPONENTS

Silicon [100]
Density: 2.32 g/cm³

TRANSDUCER

Free-surface capacitor
Time: Relative

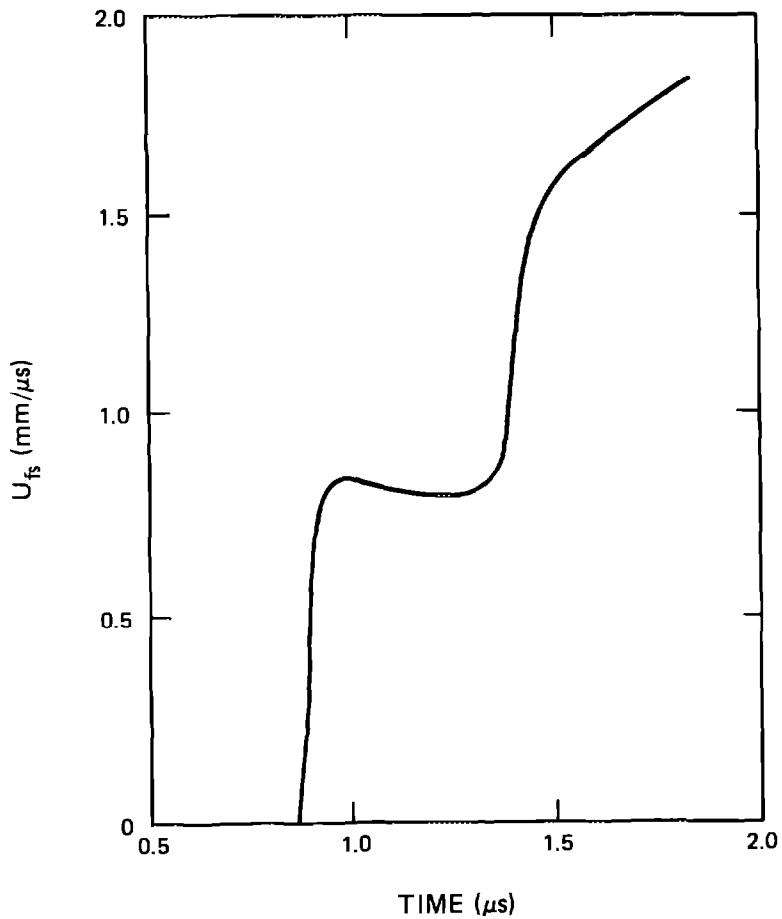

TARGET

Material: Tantalum
Experiment type: Free-surface capacitor
Experimenter: J. W. Taylor
Reference: R. G. McQueen, S. P. Marsh, J. W. Taylor, J. N. Fritz, and W. J. Carter (1970)
Shot no.: 56-67-432 **Date:** February 7, 1967
Thickness: 9.60 mm **Diameter:** 38.1 mm
Density: 16.68 g/cm³
C_L = 4.14 mm/μs **C_S** = 2.16 mm/μs

IMPACTOR

Tantalum, 3.05 mm thick, backed with low-density polyurethane foam, mounted on 51-mm-diam aluminum alloy projectile
Impact velocity: 0.390 mm/μs

TRANSDUCER

Free-surface capacitor
Time: Relative

NOTES

Shots 56-67-432, 56-67-458, and 56-67-459 are a series of overtaking unloading wave profiles at a constant impact stress.

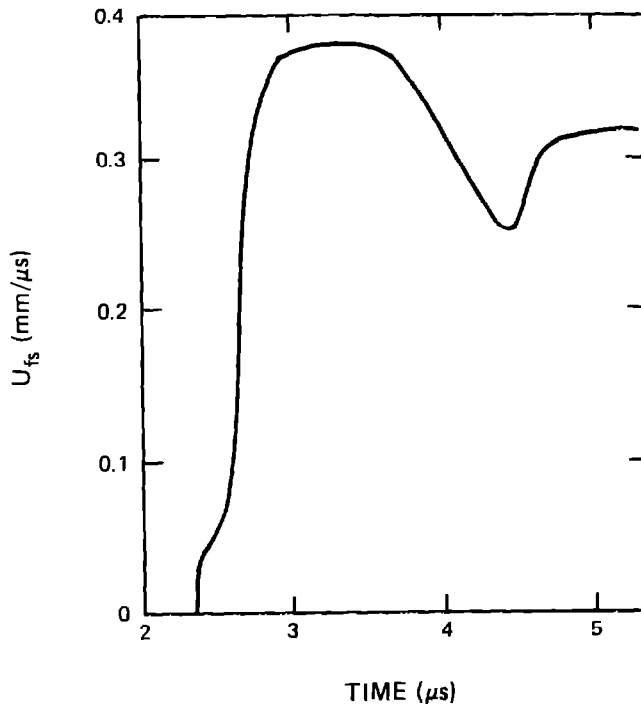

TARGET**Material:** Tantalum**Experiment type:** Free-surface capacitor**Experimenter:** J. W. Taylor**Reference:** R. G. McQueen, S. P. Marsh, J. W. Taylor, J. N. Fritz, and W. J. Carter (1970)**Shot no.:** 56-67-458 **Date:** September 5, 1967**Thickness:** 9.60 mm **Diameter:** 38.1 mm**Density:** 16.68 g/cm³ $C_L = 4.14 \text{ mm}/\mu\text{s}$ $C_S = 2.16 \text{ mm}/\mu\text{s}$ **IMPACTOR**

Tantalum, 0.51 mm thick, backed with low-density polyurethane foam, mounted on 51-mm-diam aluminum alloy projectile

Impact velocity: 0.403 mm/ μs **TRANSDUCER**

Free-surface capacitor

Time: Relative**NOTES**

Shots 56-67-432, 56-67-458, and 56-67-459 are a series of overtaking unloading wave profiles at a constant impact stress.

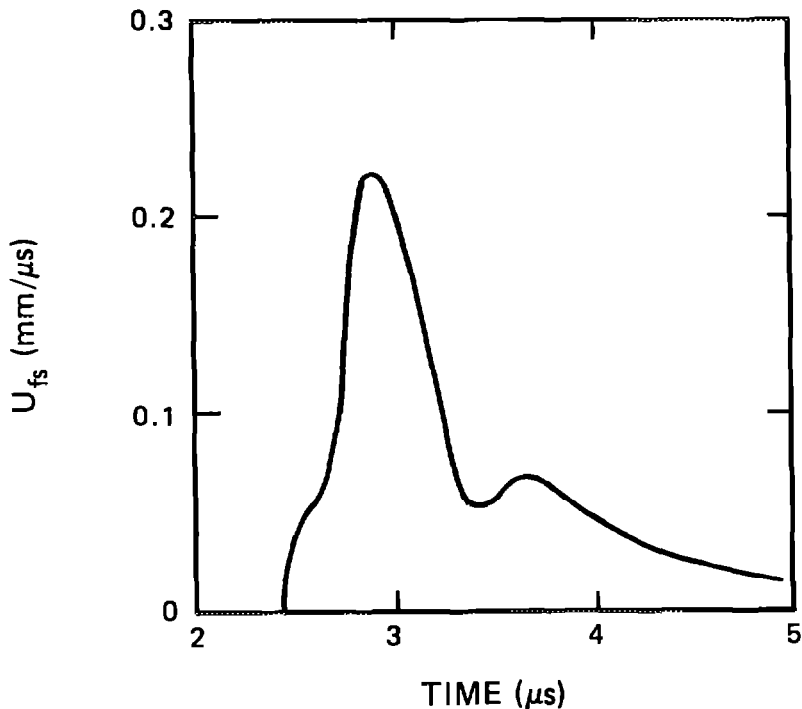

TARGET**Material:** Tantalum**Experiment type:** Free-surface capacitor**Experimenter:** J. W. Taylor**Reference:** R. G. McQueen, S. P. Marsh, J. W. Taylor, J. N. Fritz, and W. J. Carter (1970)**Shot no.:** 56-67-459 **Date:** October 24, 1967**Thickness:** 9.60 mm **Diameter:** 38.1 mm**Density:** 16.68 g/cm³**C_L** = 4.14 mm/μs **C_S** = 2.16 mm/μs**IMPACTOR**

Tantalum, 0.13 mm thick, backed with low-density polyurethane foam, mounted on 51-mm-diam aluminum alloy projectile

Impact velocity: 0.410 mm/μs**TRANSDUCER**

Free-surface capacitor

Time: Relative**NOTES**

Shots 56-67-432, 56-67-458, and 56-67-459 are a series of overtaking unloading wave profiles at a constant impact stress.

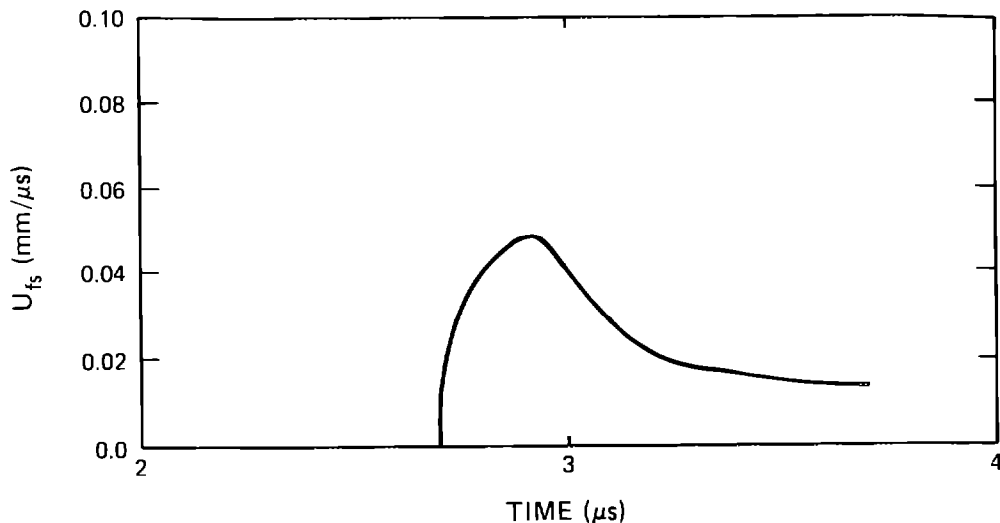

TARGET

Material: Thorium
Experiment type: Free-surface capacitor
Experimenter: J. W. Taylor
Reference: R. G. McQueen (1964)
Shot no.: 56-62-149 **Date:** September 19, 1962
Thickness: 25.40 mm **Diameter:** 152.4 mm
Density: 11.68 g/cm³
C_L = 2.95 mm/μs **C_S** = 1.57 mm/μs

IMPACTOR

Thorium mounted on 165-mm-diam aluminum alloy projectile
Impact velocity: 0.15 mm/μs

TRANSDUCER

Free-surface capacitor
Time: Relative

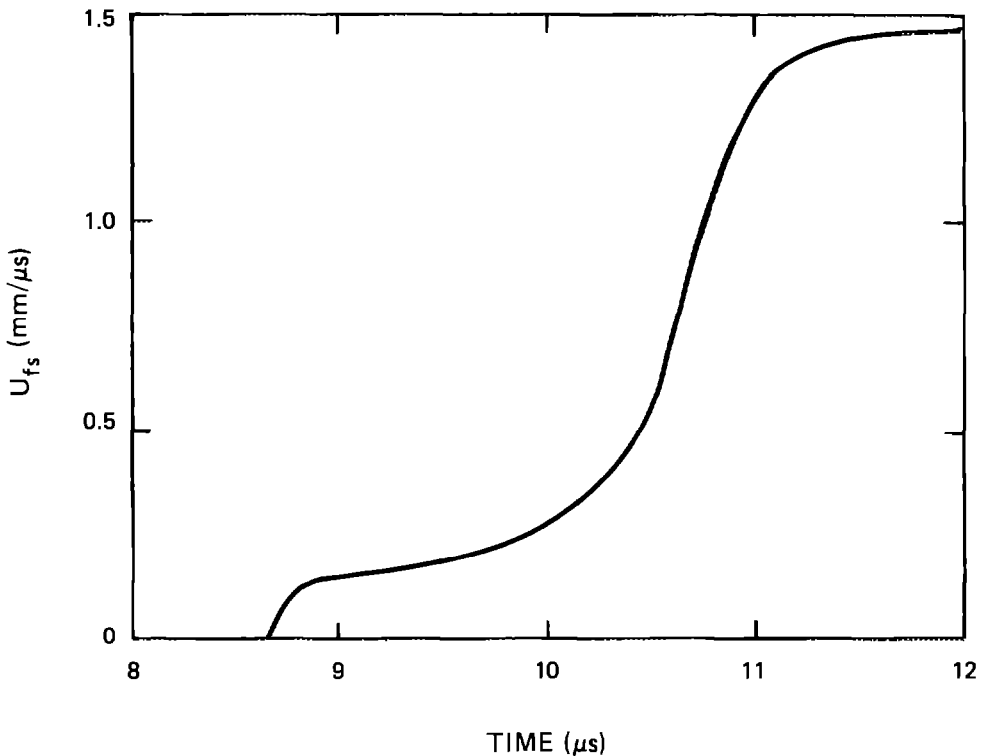

TARGET

Material: Tin

Experiment type: Free-surface capacitor

Experimenter: J. W. Hopson

Shot no.: 56-73-8 **Date:** February 14, 1973

Thickness: 8.87 mm **Diameter:** 38.1 mm

Density: 7.28 g/cm³

$C_L = 3.43$ mm/ μ s $C_S = 1.77$ mm/ μ s

IMPACTOR

OFHC copper, 4.93 mm thick, backed with low-density polyurethane foam, mounted on 51-mm-diam aluminum alloy projectile

TRANSDUCER

Free-surface capacitor

Time: Relative

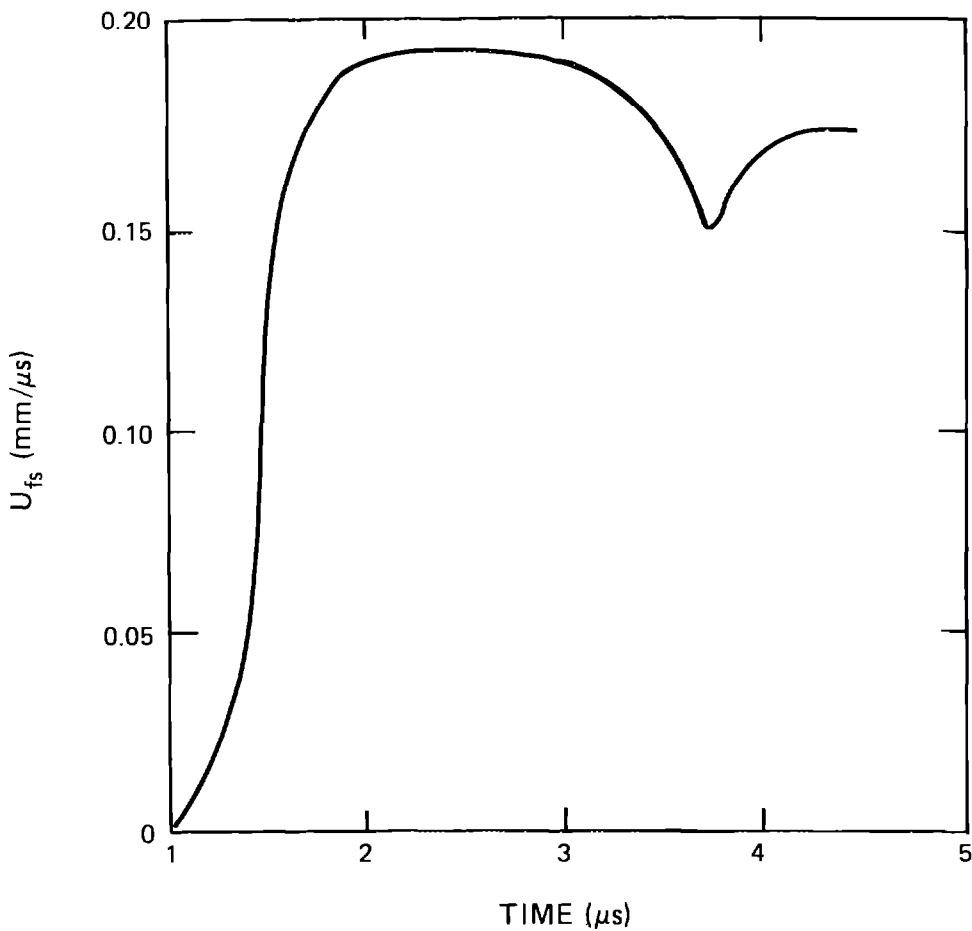

TARGET

Material: Titanium
Experiment type: Free-surface capacitor
Experimenter: J. W. Hopson
Shot no.: 56-73-27 **Date:** April 30, 1973
Thickness: 9.50 mm **Diameter:** 38.1 mm
Density: 4.52 g/cm³
C_L = 6.01 mm/μs **C_s =** 3.06 mm/μs
Heat treatment: Annealed

IMPACTOR

OFHC copper, 2.97 mm thick, backed with low-density polyurethane foam, mounted on 51-mm-diam aluminum alloy projectile
Impact velocity: 0.371 mm/μs

TRANSDUCER

Free-surface capacitor
Time: Relative

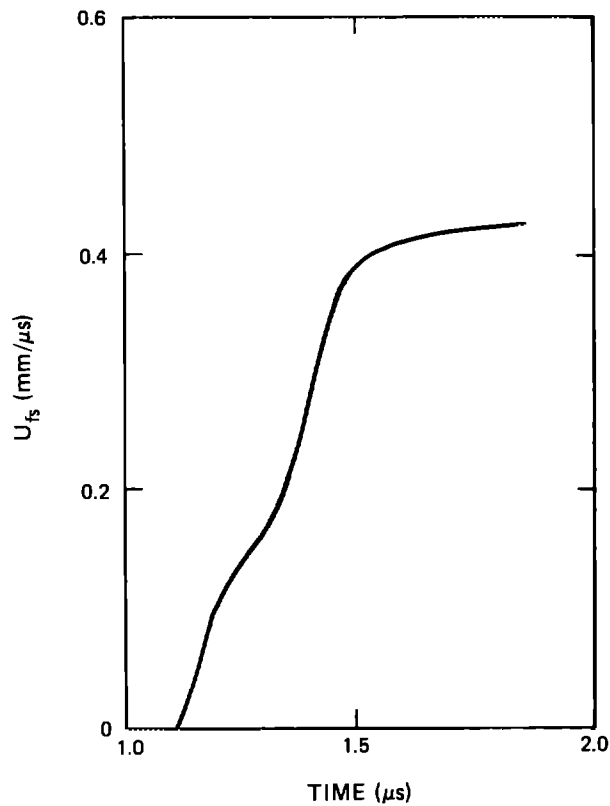

TARGET

Material: Tungsten
Experiment type: Free-surface capacitor
Experimenter: J. W. Hopson
Shot no.: 56-73-2 **Date:** February 5, 1973
Thickness: 4.93 mm **Diameter:** 38.1 mm
Density: 19.24 g/cm³
C_L = 5.18 mm/μs **C_S** = 2.85 mm/μs

IMPACTOR

OFHC copper, 4.93 mm thick, backed with low-density polyurethane foam, mounted on 51-mm-diam aluminum alloy projectile
Impact velocity: 0.306 mm/μs

TRANSDUCER

Free-surface capacitor
Time: Relative

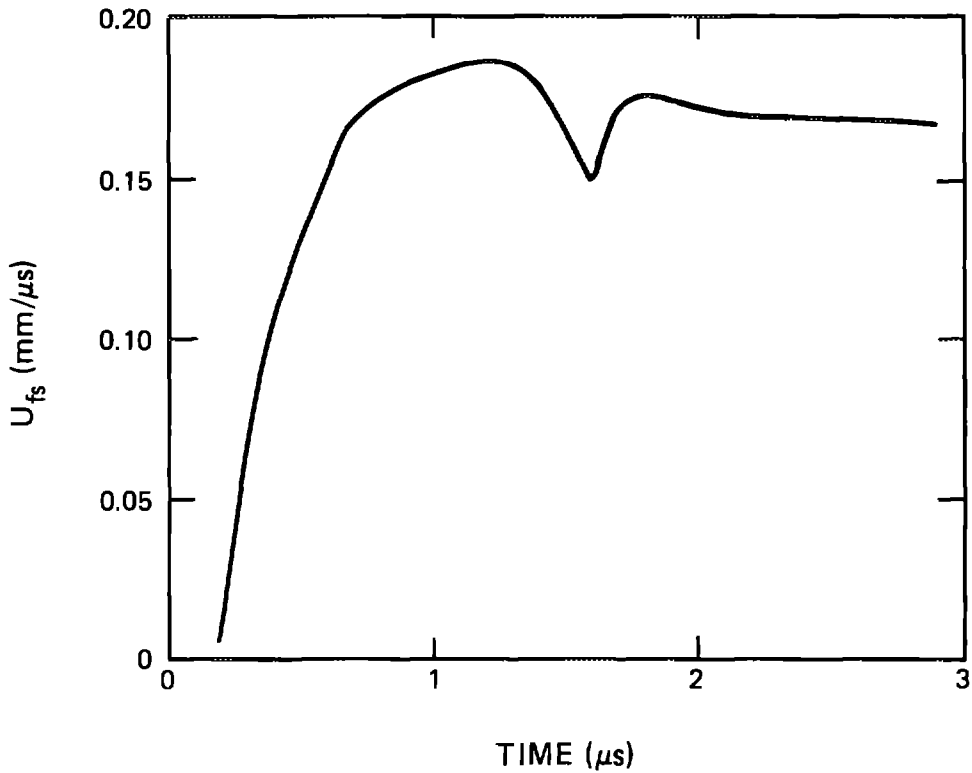

TARGET

Material: Uranium
Experiment type: Free-surface capacitor
Experimenter: J. W. Taylor
Shot no.: 56-62-144 **Date:** August 29, 1962
Thickness: 25.47 mm **Diameter:** 152 mm
Density: 19.00 g/cm³
C_L = 3.45 mm/μs **C_S** = 2.12 mm/μs

IMPACTOR

Uranium, 25.4 mm thick, mounted on 165-mm-diam aluminum alloy projectile
Impact velocity: 0.390 mm/μs

TRANSDUCER

Free-surface capacitor
Time after impact

NOTES

Shots 56-62-144, 56-62-145, and 56-62-152 are a series with varied impact stress.

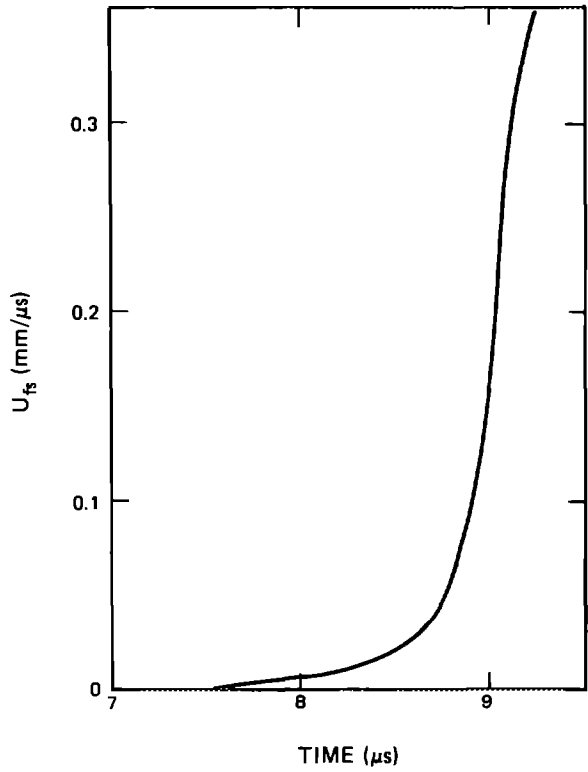

TARGET

Material: Uranium
Experiment type: Free-surface capacitor
Experimenter: J. W. Taylor
Shot no.: 56-62-145 **Date:** September 7, 1962
Thickness: 25.50 mm **Diameter:** 152 mm
Density: 19.00 g/cm³
C_L = 3.45 mm/μs **C_s** = 2.12 mm/μs

IMPACTOR

Uranium, mounted on 165-mm-diam aluminum alloy projectile
Impact velocity: 0.105 mm/μs

TRANSDUCER

Free-surface capacitor
Time after impact

NOTES

Shots 56-62-144, 56-62-145, and 56-62-152 are a series with varied impact stress.

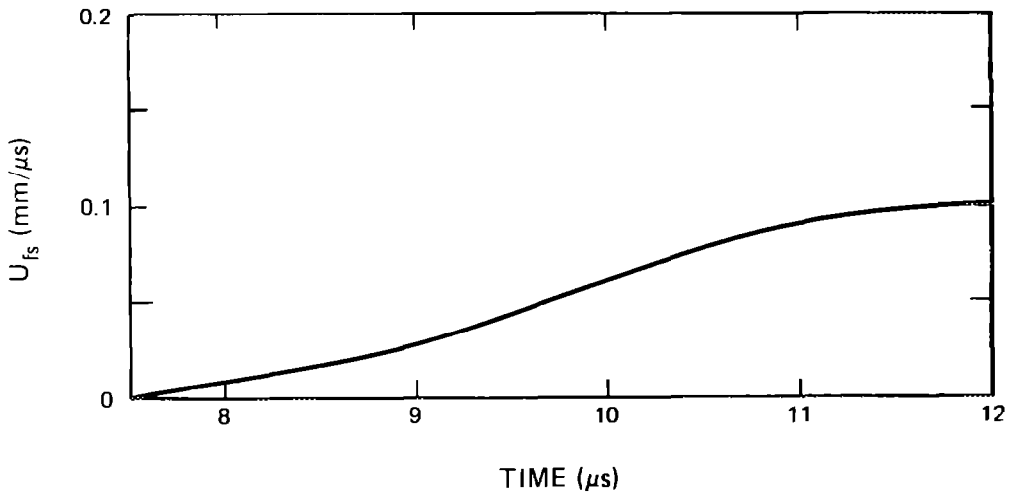

TARGET

Material: Uranium
Experiment type: Free-surface capacitor
Experimenter: J. W. Taylor
Shot no.: 56-62-146 **Date:** September 11, 1962
Thickness: 12.79 mm **Diameter:** 152 mm
Density: 19.00 g/cm³
 $C_L = 3.45$ mm/ μ s $C_s = 2.12$ mm/ μ s

IMPACTOR

Uranium, 6.35 mm thick, , backed with low-density polyurethane foam, mounted on 165-mm-diam aluminum alloy projectile
Impact velocity: 0.525 mm/ μ s

TRANSDUCER

Free-surface capacitor
Time after impact

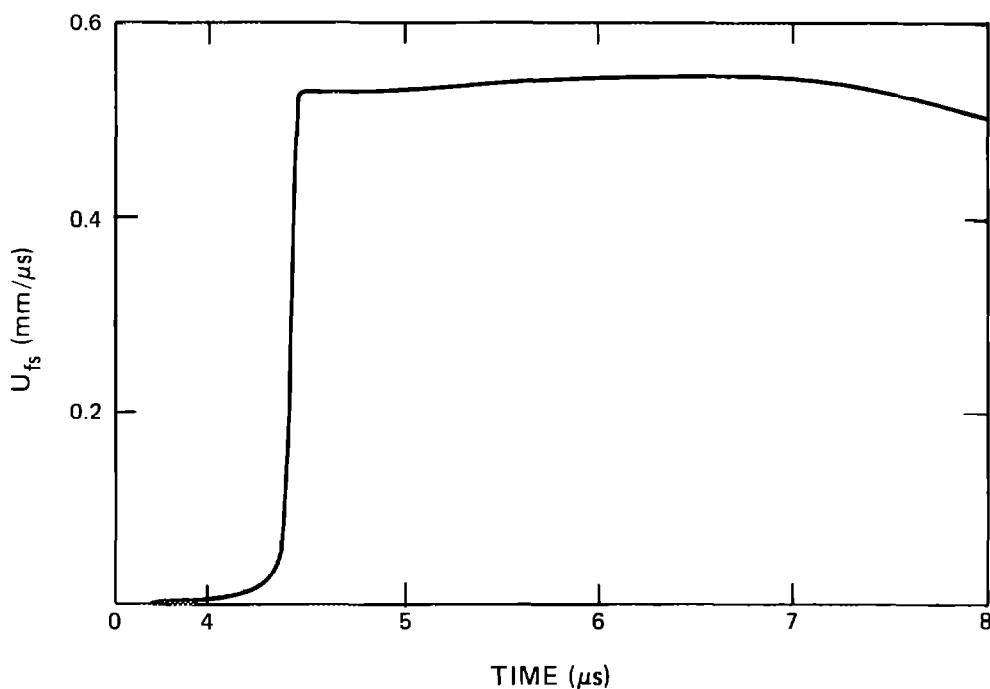

TARGET **Material:** Uranium
Experiment type: Free-surface capacitor
Experimenter: J. W. Taylor
Shot no.: 56-62-152 **Date:** October 2, 1962
Thickness: 25.48 mm **Diameter:** 152 mm
Density: 19.00 g/cm³
C_L = 3.45 mm/μs **C_S** = 2.12 mm/μs

IMPACTOR Uranium, mounted on 165-mm-diam aluminum alloy projectile
Impact velocity: 0.267 mm/μs

TRANSDUCER Free-surface capacitor
Time after impact

NOTES Shots 56-62-144, 56-62-145, and 56-62-152 are a series with varied impact stress.

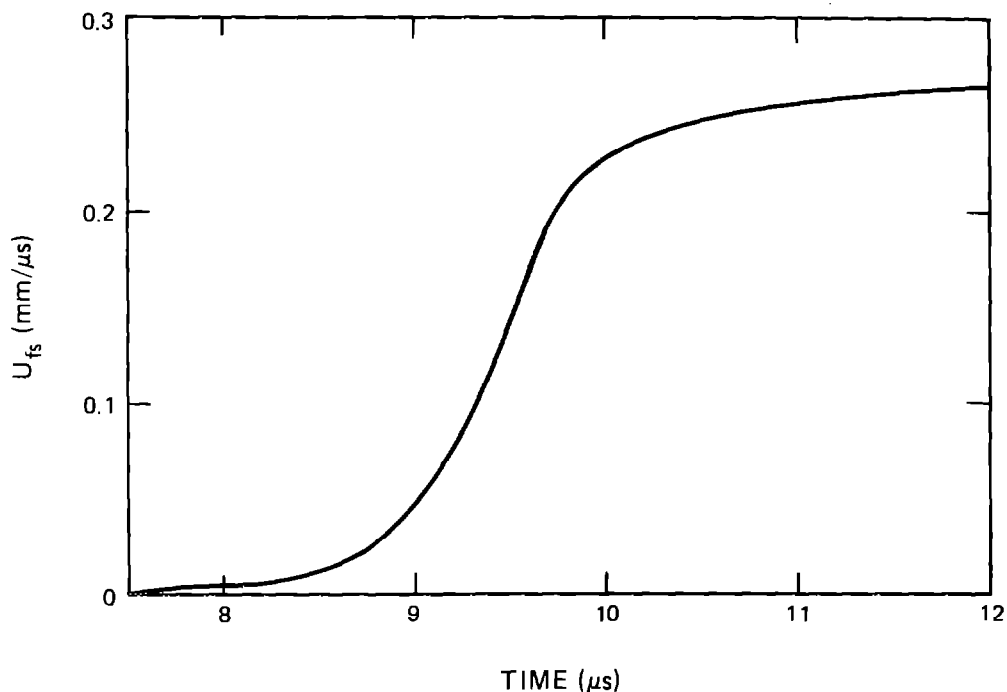

TARGET **Material:** Uranium
Experiment type: Free-surface capacitor
Experimenter: J. W. Taylor
Shot no.: 56-62-167 **Date:** December 12, 1962
Thickness: 25.40 mm **Diameter:** 152 mm
Density: 19.00 g/cm³
 $C_L = 3.45 \text{ mm}/\mu\text{s}$ $C_s = 2.12 \text{ mm}/\mu\text{s}$

IMPACTOR 12.76 mm uranium backed by 6.35 mm tungsten, mounted on
165-mm-diam aluminum alloy projectile
Impact velocity: 0.385 mm/ μs

TRANSDUCER **Free-surface capacitor**
Time after impact

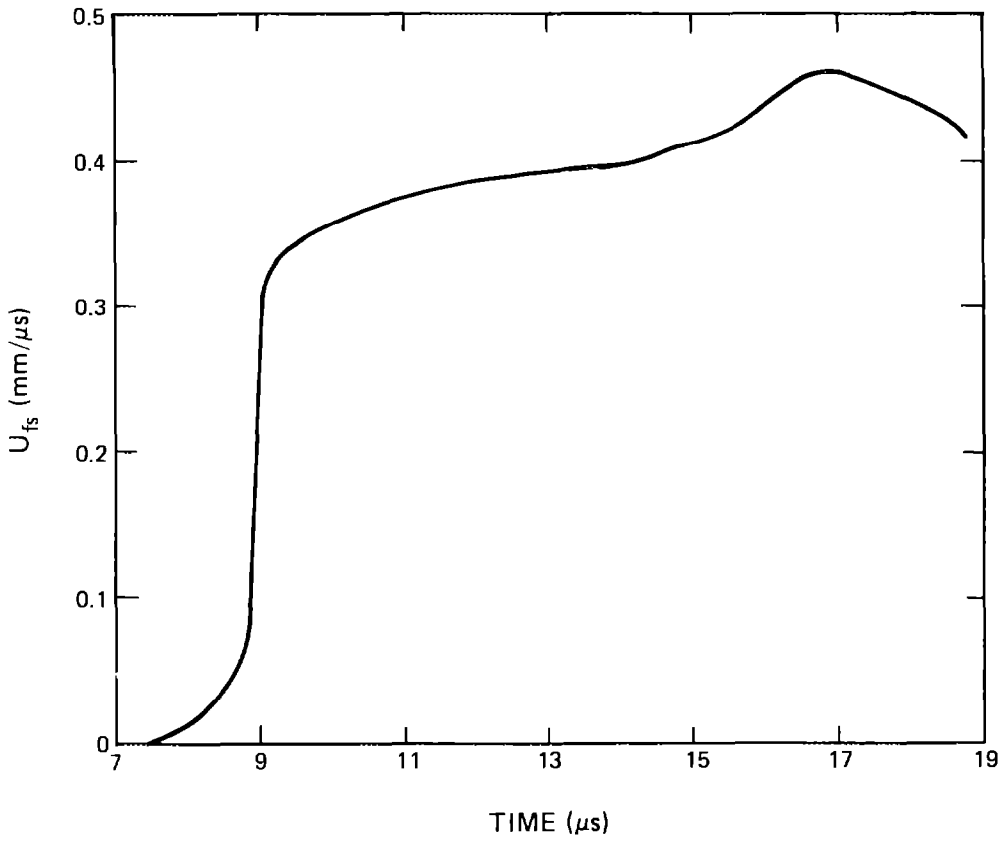

TARGET

Material: Uranium
Experiment type: Embedded Manganin gage
Experimenter: C. E. Morris
Shot no.: 56-78-87 **Date:** November 21, 1978
Thickness: 15.077 mm **Diameter:** 39.7 mm
Density: 19.000 g/cm³
C_L = 3.45 mm/μs **C_s** = 2.12 mm/μs

IMPACTOR

Uranium, 2.809 mm thick, backed with low-density polyurethane foam, mounted on 51-mm-diam aluminum alloy projectile
Impact velocity: 0.255 mm/μs

TRANSDUCER

Two-terminal, 50-Ω Manganin gage
Location from impact surface: 7.488 mm
Heat treatment: Annealed
Encapsulation: 0.53 mm Al₂O₃ [11̄02] on both sides
Calibration: J. W. Hopson and J. W. Taylor calibration formula for Manganin gages
 $\sigma = a_1 x + b_1 x^2 + c_1 x^3$ for $x < 0.1$,
 $\sigma = a_2 + b_2 x + c_2 x^2$ for $x > 0.1$,
where $x = \Delta R/R$.
a₁ = 521.32 **b₁** = -1614.86 **c₁** = 7648.72
a₂ = 6.5950 **b₂** = 370.37 **c₂** = 0.00
Time: Relative

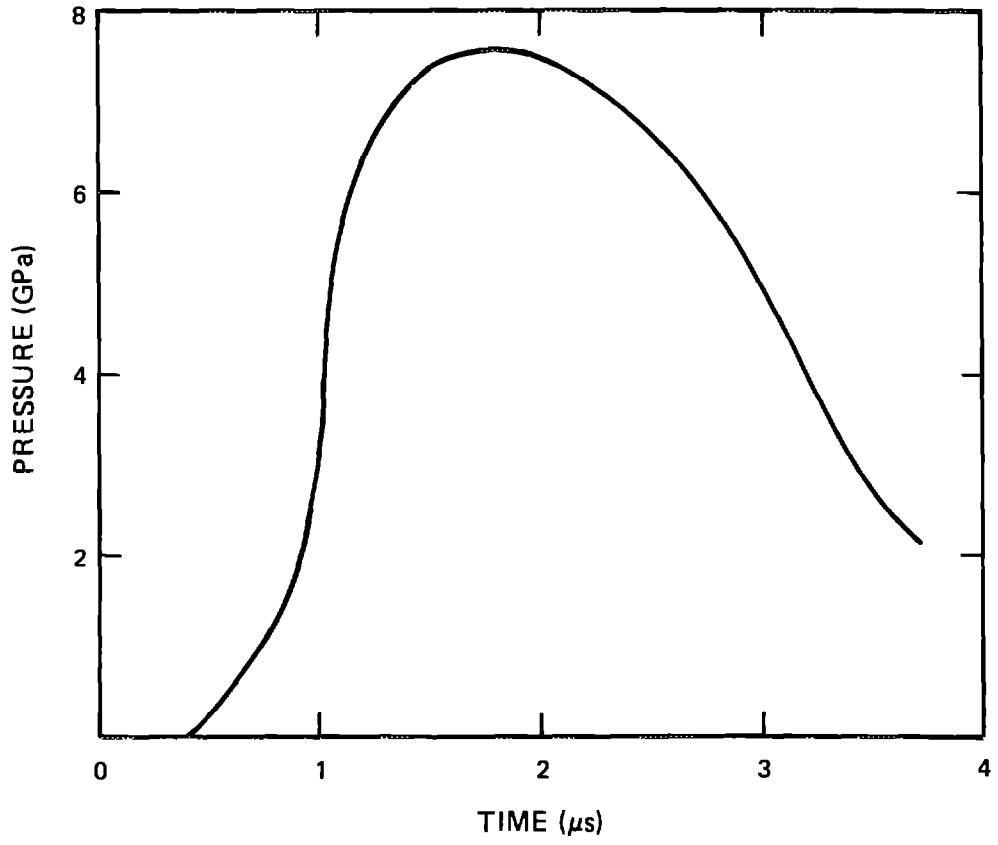

TARGET

Material: Uranium
Experiment type: Embedded Manganin gage
Experimenter: C. E. Morris
Shot no.: 56-8-88 **Date:** November 15, 1978
Thickness: 15.252 mm **Diameter:** 39.7 mm
Density: 19.000 g/cm³
 $C_L = 3.45$ mm/ μ s $C_s = 2.12$ mm/ μ s

IMPACTOR

Uranium, 2.819 mm thick, backed with low-density polyurethane foam, mounted on 51-mm-diam aluminum alloy projectile
Impact velocity: 0.481 mm/ μ s

TRANSDUCER

Two-terminal, 50- Ω Manganin gage
Location from impact surface: 7.599 mm
Heat treatment: Annealed
Encapsulation: 0.514 mm Al₂O₃ [1 $\bar{1}$ 02] on both sides
Calibration: J. W. Hopson and J. W. Taylor calibration formula for
Manganin gages
 $\sigma = a_1 x + b_1 x^2 + c_1 x^3$ for $x < 0.1$,
 $\sigma = a_2 + b_2 x + c_2 x^2$ for $x > 0.1$,
where $x = \Delta R/R$.
 $a_1 = 521.32$ $b_1 = -1614.86$ $c_1 = 7648.72$
 $a_2 = 6.5950$ $b_2 = 370.37$ $c_2 = 0.00$
Time: Relative

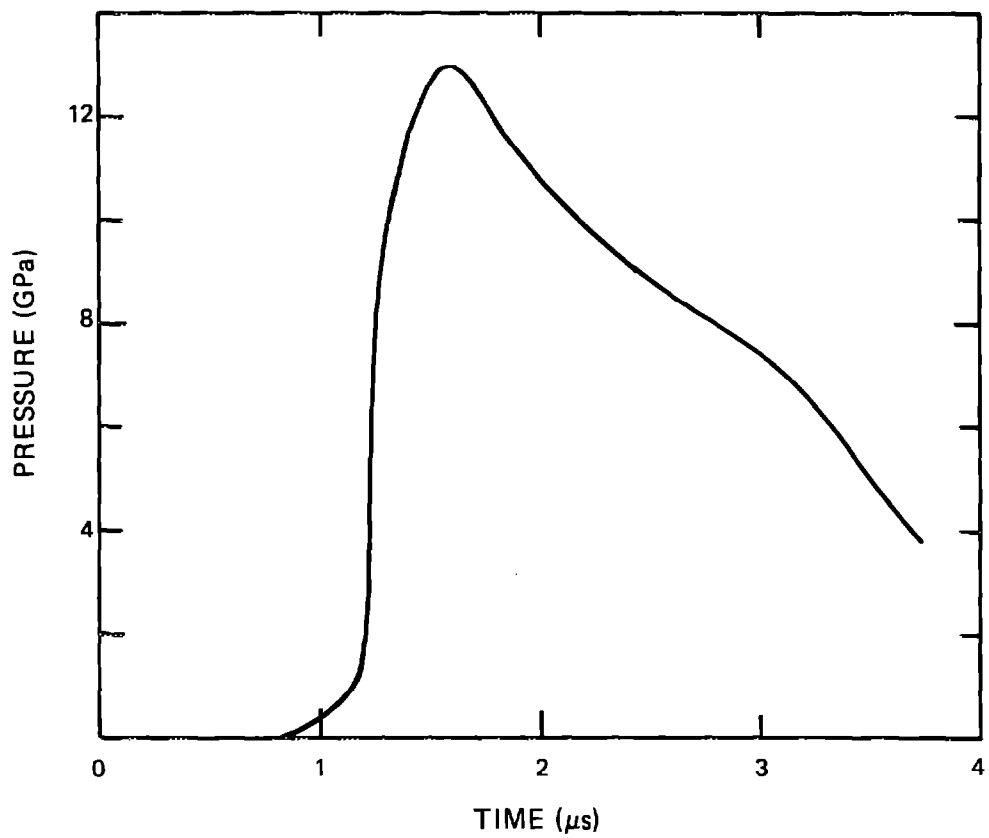

TARGET

Material: Uranium
Experiment type: Embedded Manganin gage
Experimenter: C. E. Morris
Shot no.: 56-78-89 **Date:** November 15, 1978
Thickness: 15.213 mm **Diameter:** 39.7 mm
Density: 19.000 g/cm³
C_L = 3.45 mm/μs **C_s =** 2.12 mm/μs

IMPACTOR

Uranium, 2.832 mm thick, backed with low-density polyurethane foam, mounted on 51-mm-diam aluminum alloy projectile
Impact velocity: 0.371 mm/μs

TRANSDUCER

Two-terminal, 50-Ω Manganin gage
Location from impact surface: 7.571 mm
Heat treatment: Annealed
Encapsulation: 0.53 mm Al₂O₃ [1 $\bar{1}$ 02] on both sides
Calibration: J. W. Hopson and J. W. Taylor calibration formula for
 Manganin gages
 $\sigma = a_1 x + b_1 x^2 + c_1 x^3$ for $x < 0.1$,
 $\sigma = a_2 + b_2 x + c_2 x^2$ for $x > 0.1$,
 where $x = \Delta R/R$.
a₁ = 521.32 **b₁ =** -1614.86 **c₁ =** 7648.72
a₂ = 6.5950 **b₂ =** 370.37 **c₂ =** 0.00
Time: Relative

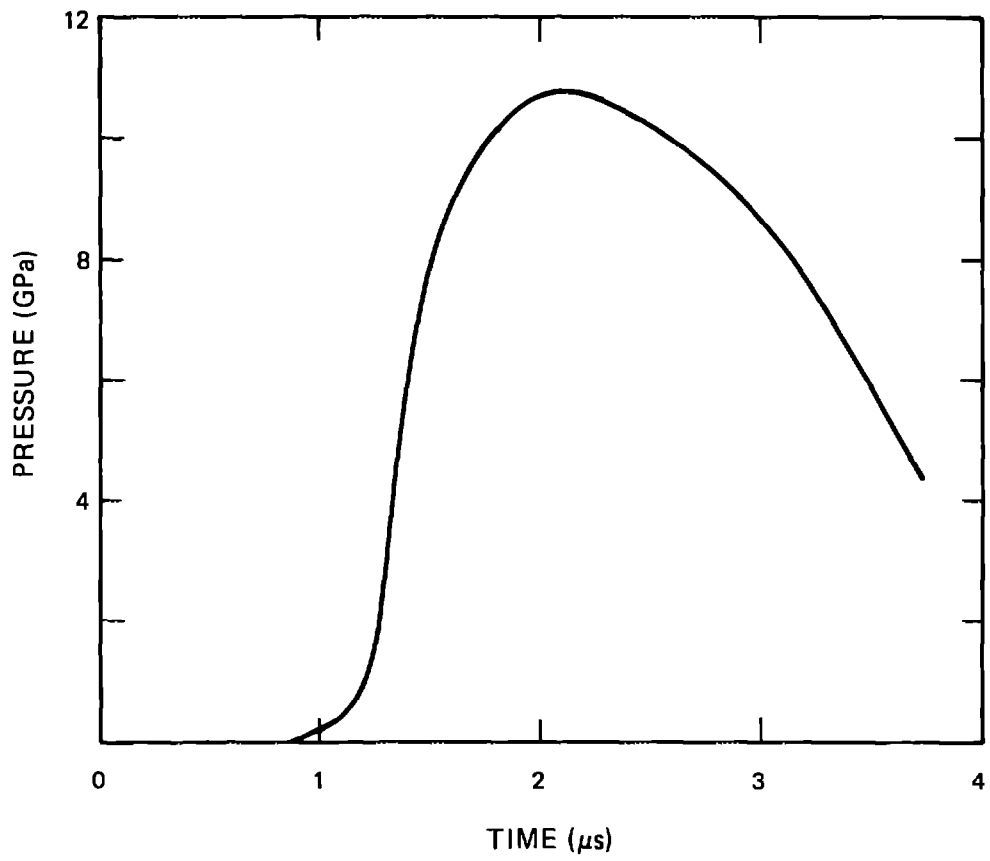

TARGET

Material: Zirconium

Experiment type: Free-surface capacitor

Experimenter: J. W. Taylor

Shot no.: 56-72-19 **Date:** February 9, 1972

Thickness: 6.34 mm **Diameter:** 38.1 mm

Density: 6.51 g/cm³

$C_L = 4.77$ mm/ μ s $C_s = 2.39$ mm/ μ s

IMPACTOR

Tantalum, 3.20 mm thick, mounted on 51-mm-diam aluminum alloy projectile

Impact velocity: 0.641 mm/ μ s

TRANSDUCER

Free-surface capacitor

Time: Relative

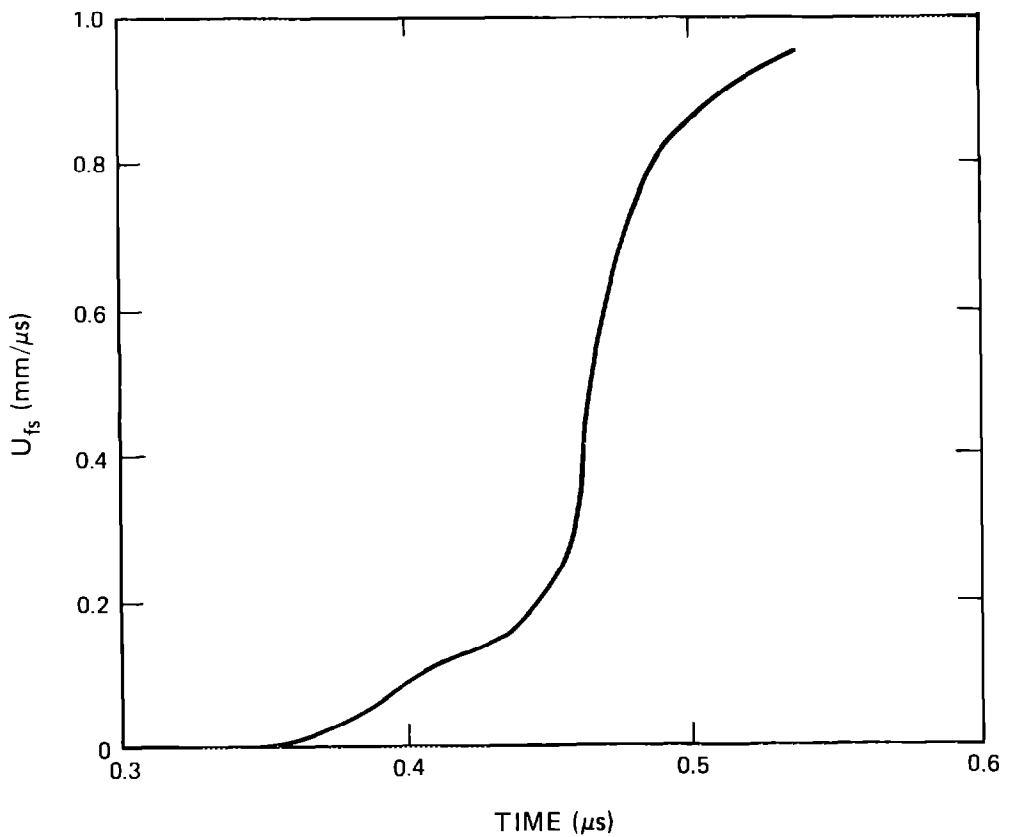

ALLOYS

TARGET

Material: 921T aluminum
Experiment type: Free-surface capacitor
Experimenter: J. W. Taylor
Shot no.: 56-63-220 **Date:** April 24, 1963
Thickness: 6.73
Density: 2.813 g/cm³
C_L = 6.29 mm/μs **C_s** = 3.11 mm/μs

IMPACTOR

Iron, 6.35 mm thick, mounted on aluminum alloy projectile
Impact velocity: 0.202 mm/μs

TRANSDUCER

Free-surface capacitor
Time: Relative

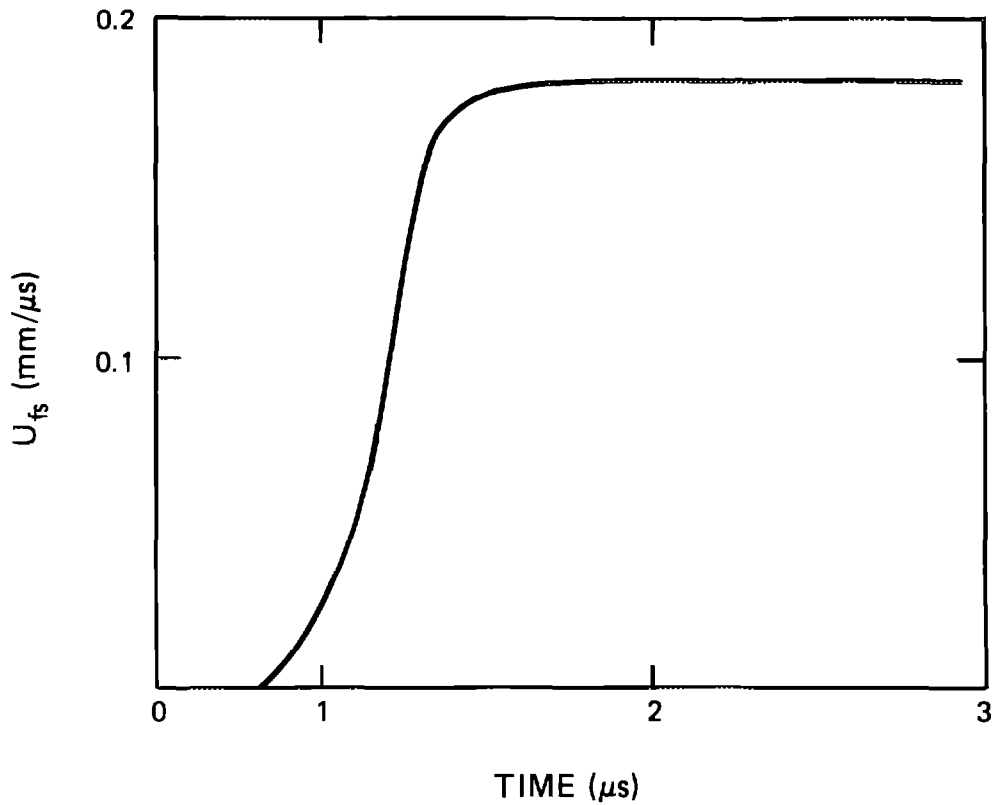

TARGET

Material: 2024 aluminum
Experiment type: Free-surface capacitor
Experimenter: M. H. Rice
Shot no.: 56-59-14 **Date:** July 14, 1959
Thickness: 38.10 mm **Diameter:** 153 mm
Density: 2.785 g/cm³
 $C_L = 6.36 \text{ mm}/\mu\text{s}$ $C_S = 3.16 \text{ mm}/\mu\text{s}$

IMPACTOR

2024 aluminum, mounted on 165-mm-diam aluminum alloy projectile
Impact velocity: 0.175 mm/ μs

TRANSDUCER

Free-surface capacitor
Time: Relative

NOTES

This was the first free-surface capacitor record.

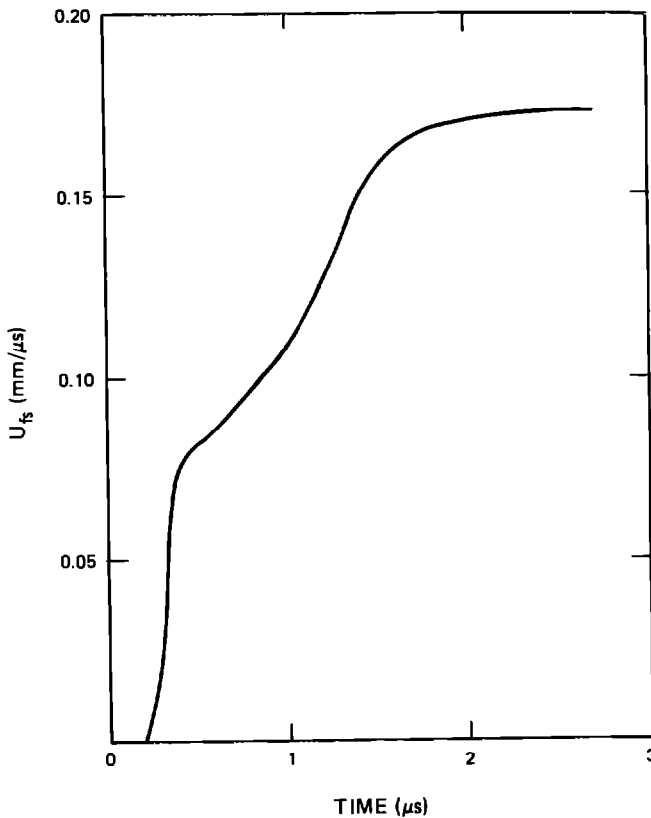

TARGET

Material: 2024 aluminum
Experiment type: Free-surface capacitor
Experimenters: M. H. Rice and J. W. Taylor
Reference: R. G. McQueen (1964)
Shot no.: 56-60-35 **Date:** June 6, 1960
Thickness: 76.20 mm **Diameter:** 152 mm
Density: 2.785 g/cm³
C_L = 6.36 mm/μs **C_S** = 3.16 mm/μs

IMPACTOR

2024 aluminum, 51 mm thick, mounted on 165-mm-diam aluminum alloy projectile
Impact velocity: 0.117 mm/μs

TRANSDUCER

Free-surface capacitor
Time: Relative

NOTES

Shots 56-60-35, 56-60-38, and 56-60-41 are a series with varied impact stress.

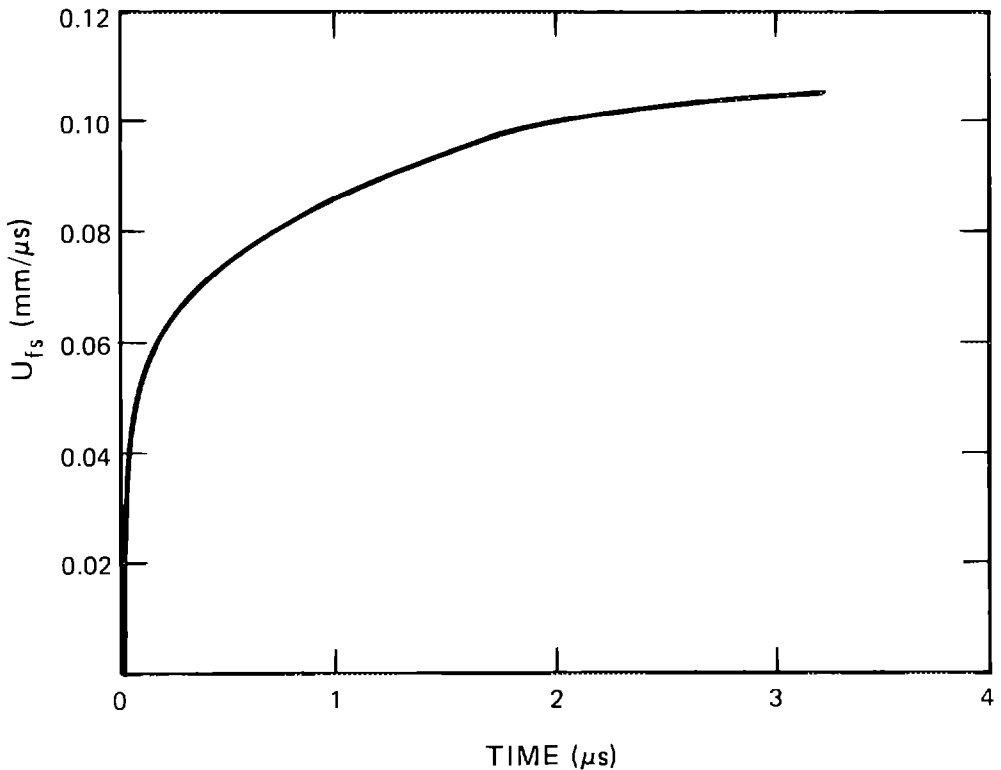

TARGET

Material: 2024 aluminum
Experiment type: Free-surface capacitor
Experimenters: M. H. Rice and J. W. Taylor
Reference: R. G. McQueen (1964)
Shot no.: 56-60-38 **Date:** June 16, 1960
Thickness: 76.20 mm **Diameter:** 152 mm
Density: 2.785 g/cm³
C_L = 6.36 mm/μs **C_s** = 3.16 mm/μs

IMPACTOR

2024 aluminum, 51 mm thick, mounted on 165-mm-diam aluminum alloy projectile
Impact velocity: 0.307 mm/μs

TRANSDUCER

Free-surface capacitor
Time: Relative

NOTES

Shots 56-60-35, 56-60-38, and 56-60-41 are a series with varied impact stress.

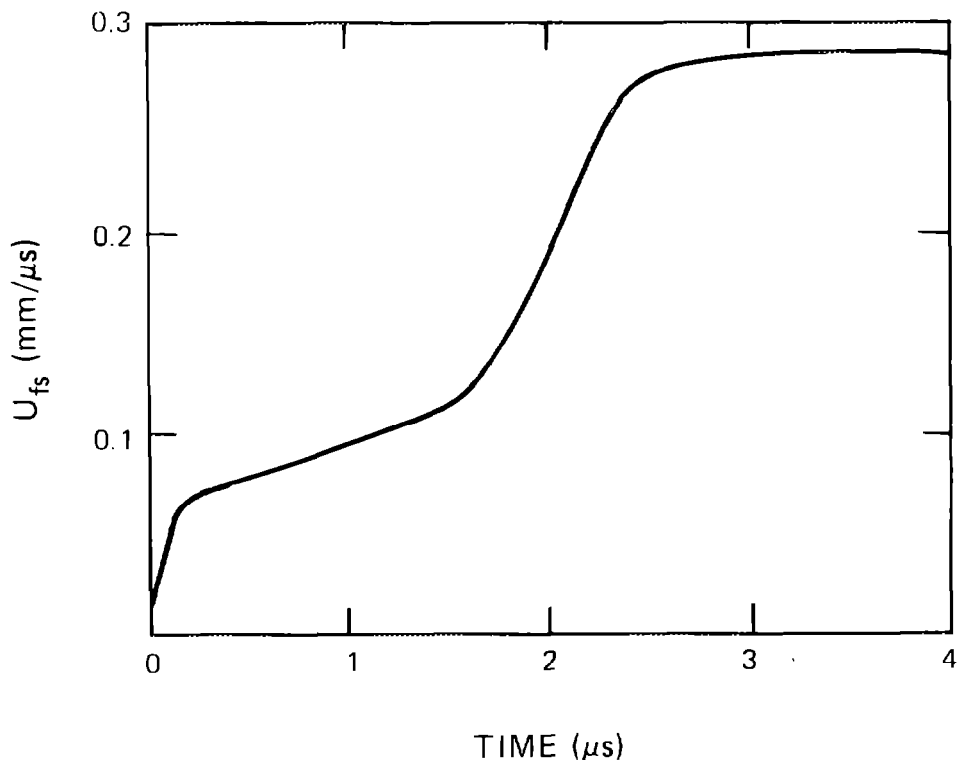

TARGET**Material:** 2024 aluminum**Experiment type:** Free-surface capacitor**Experimenters:** M. H. Rice and J. W. Taylor**Reference:** R. G. McQueen (1964)**Shot no.:** 56-60-41 **Date:** June 24, 1960**Thickness:** 76.20 mm **Diameter:** 152 mm**Density:** 2.785 g/cm³**C_L** = 6.36 mm/μs **C_S** = 3.16 mm/μs**IMPACTOR**

2024 aluminum, 51 mm thick, mounted on 165-mm-diam aluminum alloy projectile

Impact velocity: 0.168 mm/μs**TRANSDUCER**

Free-surface capacitor

Time: Relative**NOTES**

Shots 56-60-35, 56-60-38, and 56-60-41 are a series with varied impact stress.

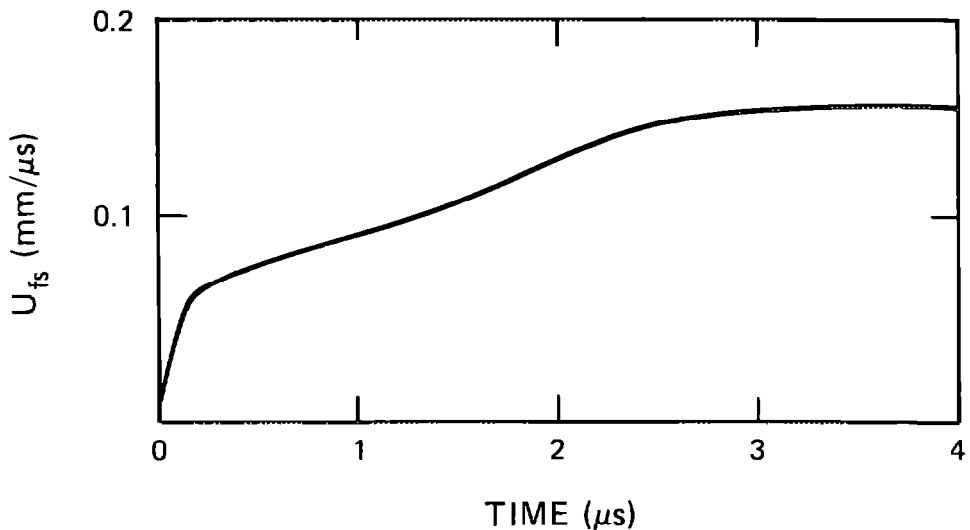

TARGET

Material: 2024 aluminum
Experiment type: Free-surface capacitor
Experimenter: J. W. Taylor
Reference: J. W. Taylor (1968)
Shot no.: 56-65-394 **Date:** May 22, 1965
Thickness: 12.70 mm
Density: 2.785 g/cm³
 $C_L = 6.36 \text{ mm}/\mu\text{s}$ $C_S = 3.16 \text{ mm}/\mu\text{s}$

IMPACTOR

2024 aluminum, 3.18 mm thick, backed by iron, mounted on aluminum alloy projectile

TRANSDUCER

Free-surface capacitor
Time: Relative

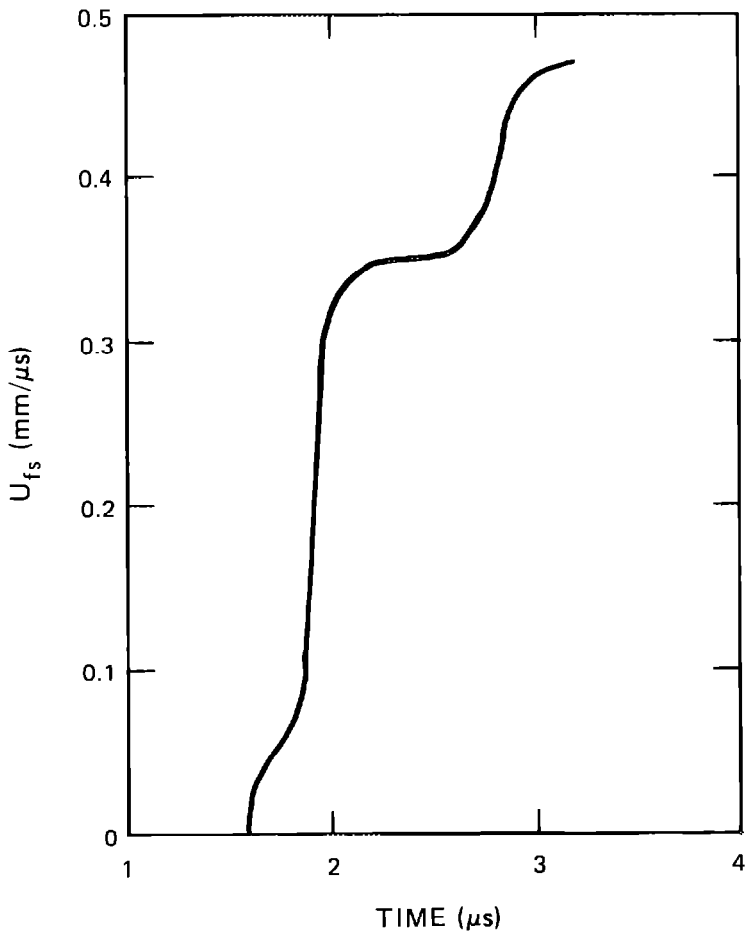

TARGET

Material: 2024 aluminum
Experiment type: Free-surface capacitor
Experimenter: J. W. Taylor
Reference: J. W. Taylor (1968)
Shot no.: 56-66-407 Date: December 12, 1966
Thickness: 12.70 mm Diameter: 152.4 mm
Density: 2.785 g/cm³
 $C_L = 6.36 \text{ mm}/\mu\text{s}$ $C_S = 3.16 \text{ mm}/\mu\text{s}$

IMPACTOR

2024 aluminum, 3.18 mm thick, backed with low-density polyurethane foam, mounted on 165-mm-diam aluminum alloy projectile
Impact velocity: 1.00 mm/ μs

TRANSDUCER

Free-surface capacitor
Time: Relative

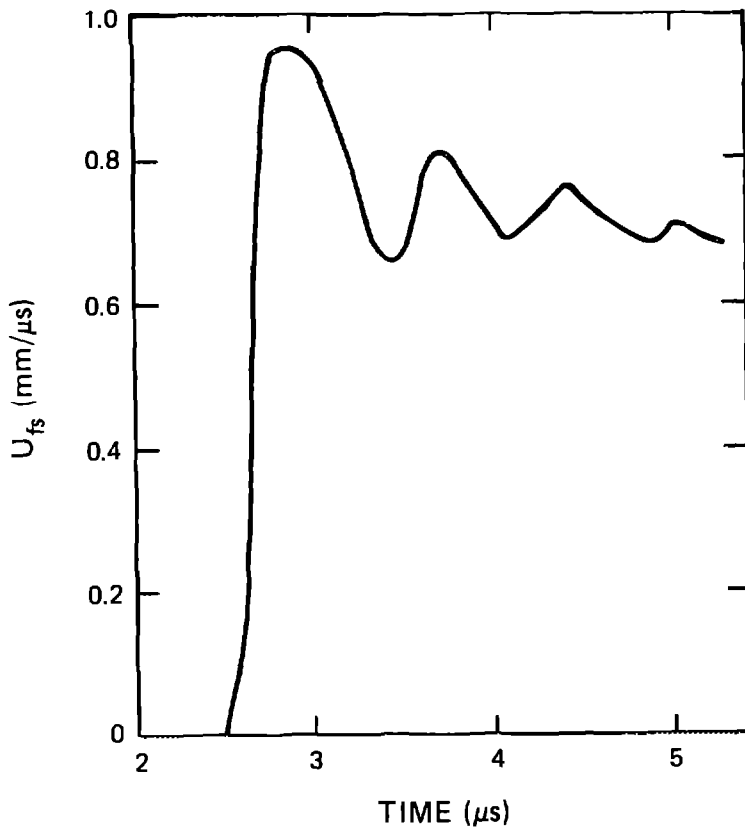

TARGET

Material: 2024 aluminum
Experiment type: Free-surface capacitor
Experimenter: J. W. Taylor
Reference: J. W. Taylor (1968)
Shot no.: 56-66-412 **Date:** December 23, 1966
Thickness: 12.70 mm **Diameter:** 152.4 mm
Density: 2.785 g/cm³
 $C_L = 6.36 \text{ mm}/\mu\text{s}$ $C_S = 3.16 \text{ mm}/\mu\text{s}$

IMPACTOR

2024 aluminum, 6.35 mm thick, backed with low-density polyurethane foam, mounted on 165-mm-diam aluminum alloy projectile
Impact velocity: 0.995 mm/ μs

TRANSDUCER

Free-surface capacitor
Time: Relative

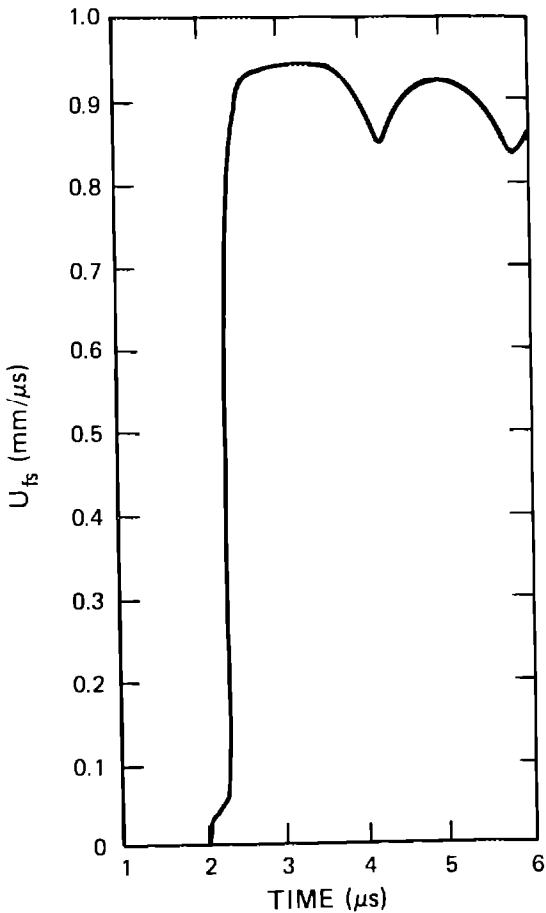

TARGET

Material: 2024 Aluminum
Experiment type: Free-surface capacitor
Experimenter: J. W. Taylor
Reference: J. W. Taylor (1968)
Shot no.: 56-66-383 **Date:** June 21, 1966
Thickness: 12.70 mm **Diameter:** 38.1 mm
Density: 2.785 g/cm³
 $C_L = 6.36 \text{ mm}/\mu\text{s}$ $C_s = 3.16 \text{ mm}/\mu\text{s}$

IMPACTOR

2024 aluminum, 3.18 mm thick, backed with low-density polyurethane foam, mounted on 51-mm-diam aluminum alloy projectile
Impact velocity: 0.408 mm/ μs

TRANSDUCER

Free-surface capacitor
Time: Relative

NOTES

Shots 56-66-383, 56-67-414, 56-67-415, and 56-67-424 are a series of overtaking unloading wave profiles with varied driver thicknesses.

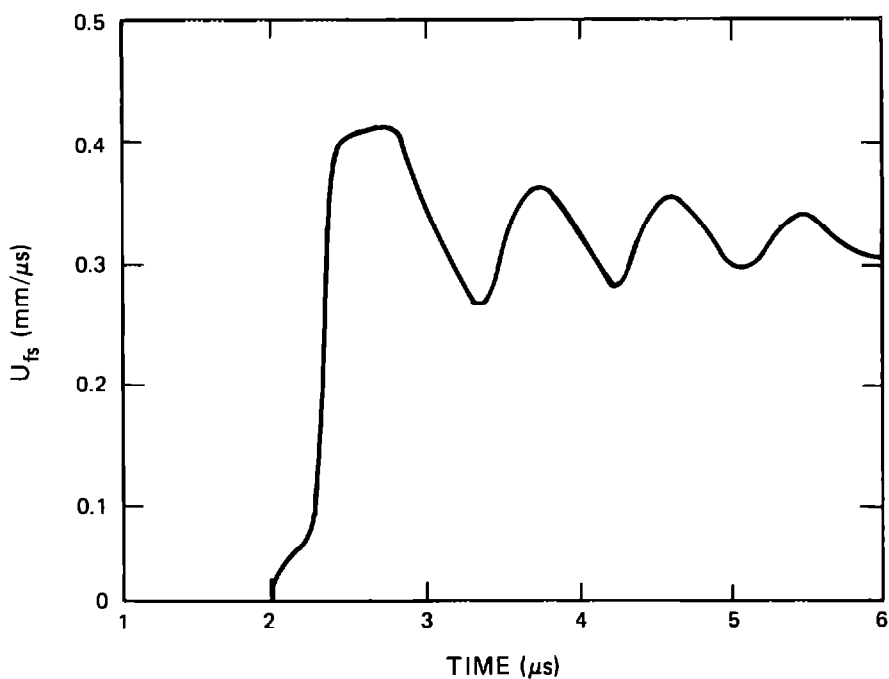

TARGET

Material: 2024 aluminum
Experiment type: Free-surface capacitor
Experimenter: J. W. Taylor
Shot no.: 56-67-414 **Date:** January 10, 1967
Thickness: 12.70 mm **Diameter:** 38.1 mm
Density: 2.785 g/cm³
C_L = 6.36 mm/μs **C_S** = 3.16 mm/μs

IMPACTOR

2024 aluminum, 1.47 mm thick, backed with low-density polyurethane foam, mounted on 51-mm-diam aluminum alloy projectile
Impact velocity: 0.455 mm/μs

TRANSDUCER

Free-surface capacitor
Time: Relative

NOTES

Shots 56-66-383, 56-67-414, 56-67-415, and 56-67-424 are a series of overtaking unloading wave profiles with varied driver thicknesses.

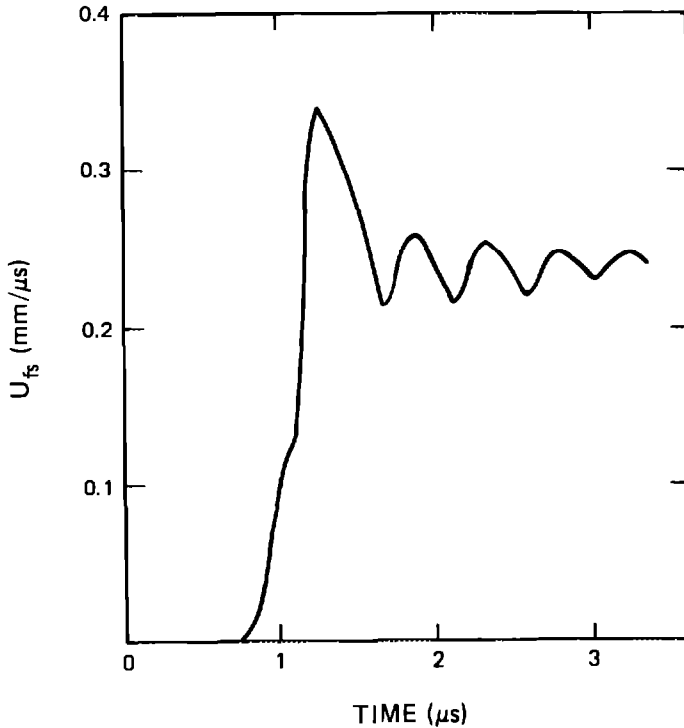

TARGET

Material: 2024 aluminum
Experiment type: Free-surface capacitor
Experimenter: J. W. Taylor
Shot no.: 56-67-415 **Date:** January 10, 1967
Thickness: 12.70 mm **Diameter:** 38.1 mm
Density: 2.785 g/cm³
 $C_L = 6.36 \text{ mm}/\mu\text{s}$ $C_S = 3.16 \text{ mm}/\mu\text{s}$

IMPACTOR

2024 aluminum, 2.03 mm thick, backed with low-density polyurethane foam, mounted on 51-mm-diam aluminum alloy projectile
Impact velocity: 0.410 mm/ μs

TRANSDUCER

Free-surface capacitor
Time: Relative

NOTES

Shots 56-66-383, 56-67-414, 56-67-415, and 56-67-424 are a series of overtaking unloading wave profiles with varied driver thicknesses.

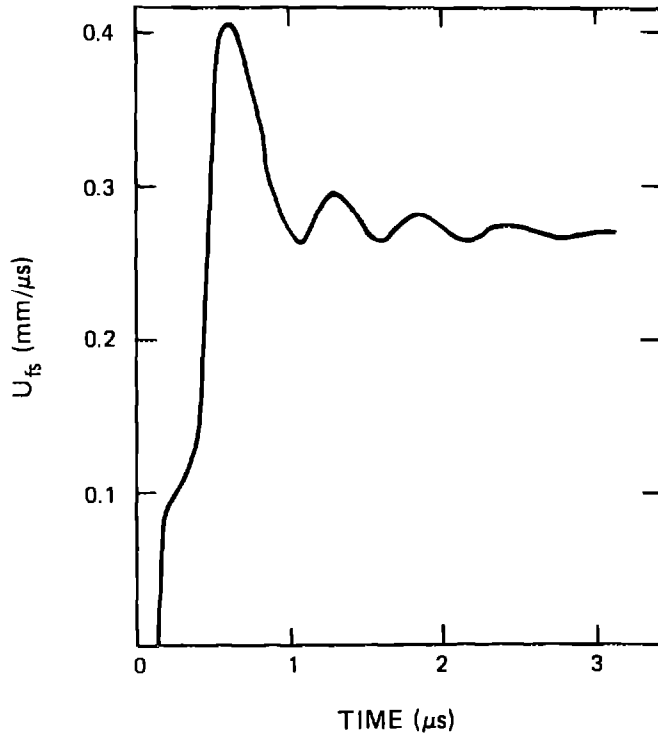

TARGET **Material:** 2024 aluminum
Experiment type: Free-surface capacitor
Experimenter: J. W. Taylor
Shot no.: 56-67-424 **Date:** March 3, 1967
Thickness: 12.70 mm **Diameter:** 38.1 mm
Density: 2.785 g/cm³
C_L = 6.36 mm/μs **C_s** = 3.16 mm/μs

IMPACTOR 2024 aluminum, 0.076 mm thick, backed with low-density polyurethane foam, mounted on 51-mm-diam aluminum alloy projectile
Impact velocity: 0.413 mm/μs

TRANSDUCER Free-surface capacitor
Time: Relative

NOTES Shots 56-66-383, 56-67-414, 56-67-415, and 56-67-424 are a series of overtaking unloading wave profiles with varied driver thicknesses.

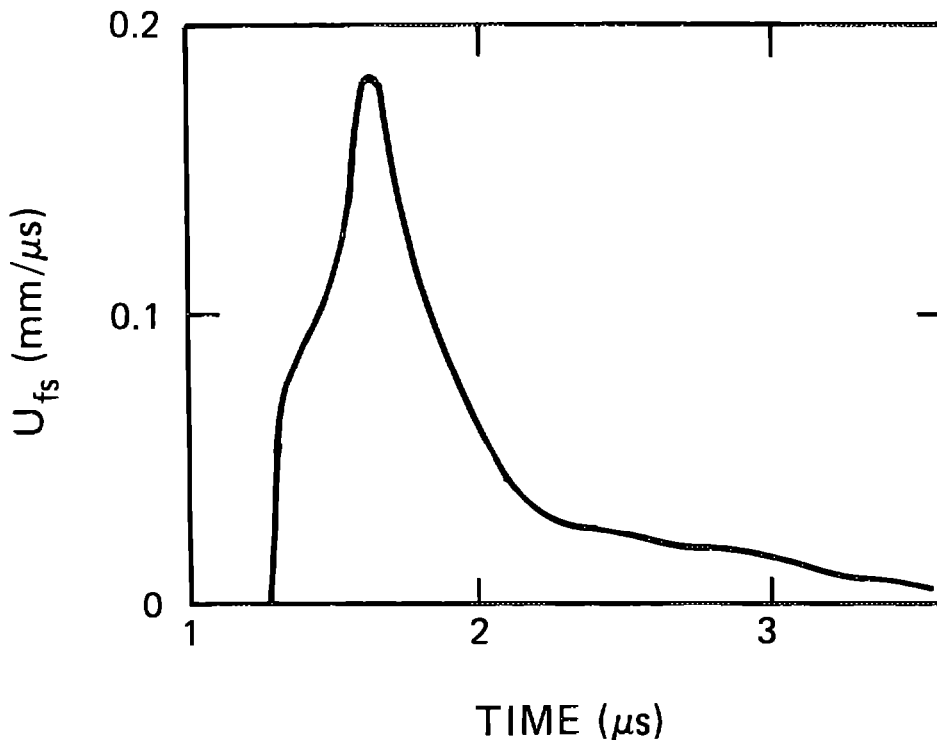

TARGET

Material: 2024 aluminum
Experiment type: ASM probe
Experimenters: C. E. Morris and J. N. Fritz
Shot no.: 88S86 **Date:** January 26, 1981

HE SHOT GEOMETRY

P-120 lens/152 mm cyclotol/89 mm PBX 9501/6.35 mm air/0.25 mm polyethylene/3.228 mm 2024 aluminum/25 mm HE/4.184 mm 2024 aluminum//epoxy/6.003 mm Teflon//

SHOT COMPONENTS

2024 aluminum
Density: 2.785 g/cm³
 $C_L = 6.36 \text{ mm}/\mu\text{s}$ $C_S = 3.16 \text{ mm}/\mu\text{s}$
Teflon
Density: 2.151 g/cm³
 $C_L = 1.23 \text{ mm}/\mu\text{s}$ $C_S = 0.41 \text{ mm}/\mu\text{s}$

TRANSDUCER

ASM probe
Coil radius: 19.148 mm **Initial coil spacing:** 6.601 mm

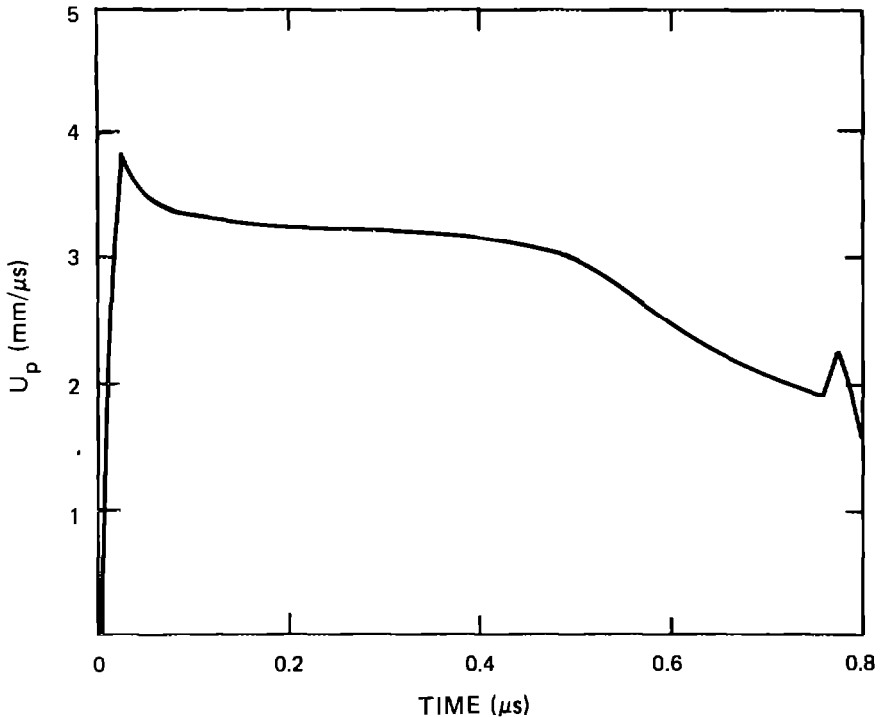

TARGET

Material: 2024 aluminum
Experiment type: ASM probe
Experimenters: C. E. Morris and J. N. Fritz
Shot no.: 88S83 **Date:** January 23, 1981

HE SHOT GEOMETRY

P-120 lens/229 mm cyclotol/51 mm PBX 9501/6.35 mm air/0.25 mm polyethylene/5.072 mm 2024 aluminum/2.5 mm HE/7.016 mm 2024 aluminum//epoxy/10.014 mm Teflon//

SHOT COMPONENTS

2024 aluminum
Density: 2.785 g/cm³
 $C_L = 6.36$ mm/ μ s $C_S = 3.16$ mm/ μ s
Teflon
Density: 2.151 g/cm³
 $C_L = 1.23$ mm/ μ s $C_S = 0.41$ mm/ μ s

TRANSDUCER

ASM probe
Coil radius: 25.499 mm **Initial coil spacing:** 10.624 mm

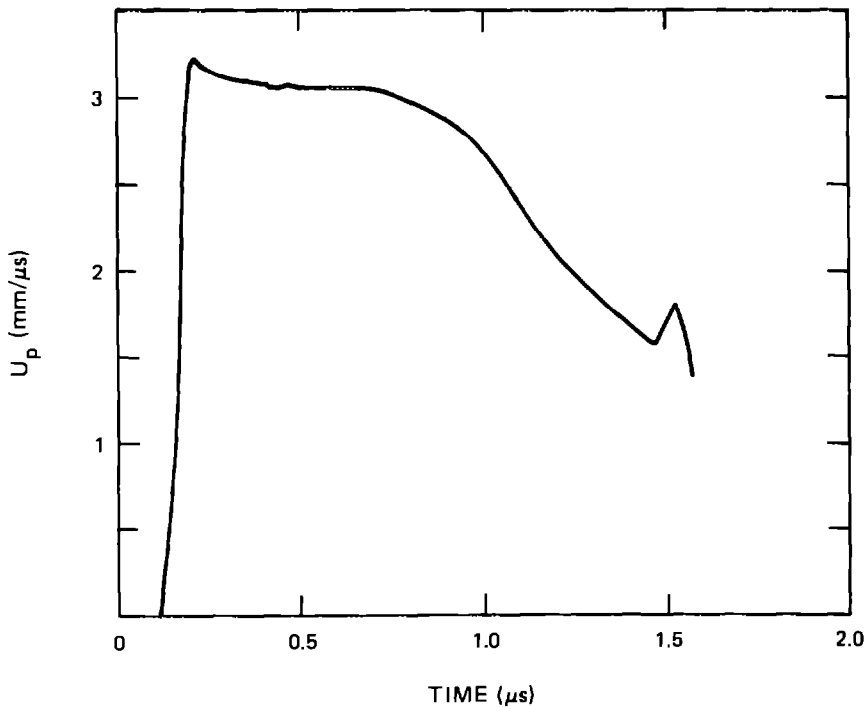

TARGET

Material: 2024 aluminum
Experiment type: ASM probe
Experimenters: C. E. Morris and J. N. Fritz
Shot no.: 88S85 **Date:** January 26, 1981

HE SHOT GEOMETRY

P-120 lens/203 mm Comp B/6.35 mm air/0.25 mm polyethylene/6.368 mm 2024 aluminum/25 mm HE/9.009 mm 2024 aluminum//epoxy/10.980 mm Teflon//

SHOT COMPONENTS

2024 aluminum
Density: 2.785 g/cm³
 $C_L = 6.36 \text{ mm}/\mu\text{s}$ $C_S = 3.16 \text{ mm}/\mu\text{s}$
Teflon
Density: 2.151 g/cm³
 $C_L = 1.23 \text{ mm}/\mu\text{s}$ $C_S = 0.41 \text{ mm}/\mu\text{s}$

TRANSDUCER

ASM probe
Coil radius: 25.497 mm **Initial coil spacing:** 11.571 mm

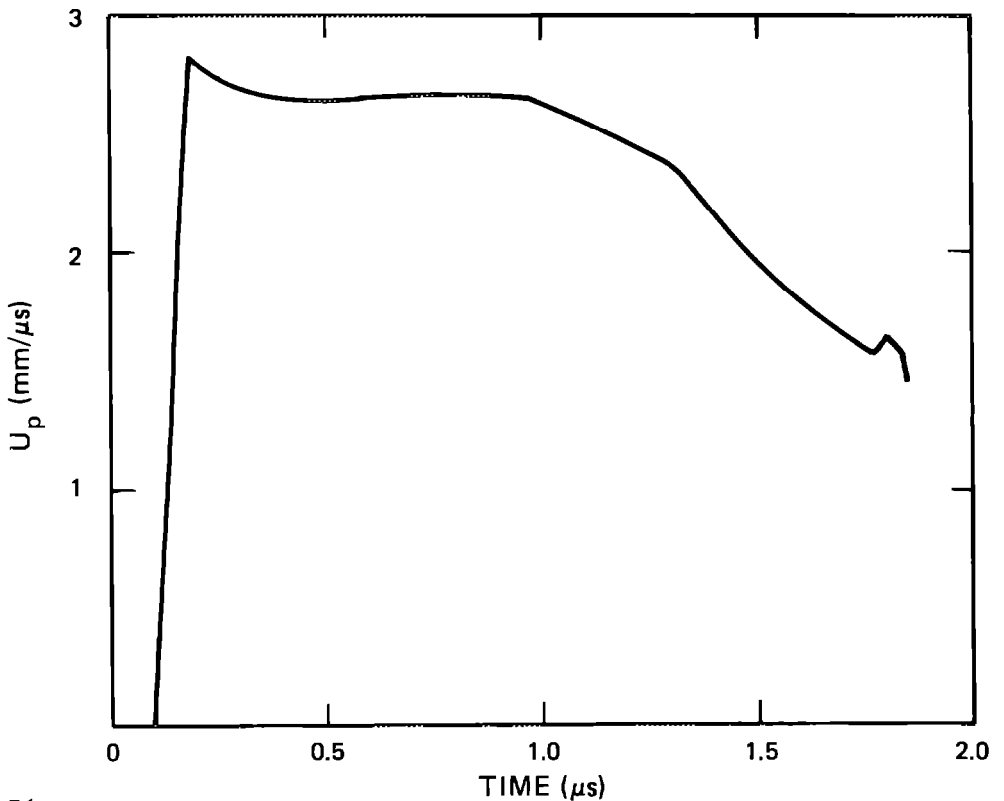

TARGET

Material: 2024 aluminum
Experiment type: ASM probe
Experimenters: C. E. Morris and J. N. Fritz
Shot no.: 57S88 **Date:** March 11, 1981

HE SHOT GEOMETRY

P-120 lens/152 mm baratol/12.7 mm air/0.25 mm poly-ethylene/6.370 mm 2024 aluminum/25 mm HE/11.006 mm 2024 aluminum//epoxy/10.012 mm Teflon//

SHOT COMPONENTS

2024 aluminum
Density: 2.785 g/cm³
 $C_L = 6.36$ mm/ μ s $C_S = 3.16$ mm/ μ s
Teflon
Density: 2.151 g/cm³
 $C_L = 1.23$ mm/ μ s $C_S = 0.41$ mm/ μ s

TRANSDUCER

ASM probe
Coil radius: 25.479 mm **Initial coil spacing:** 10.571 mm

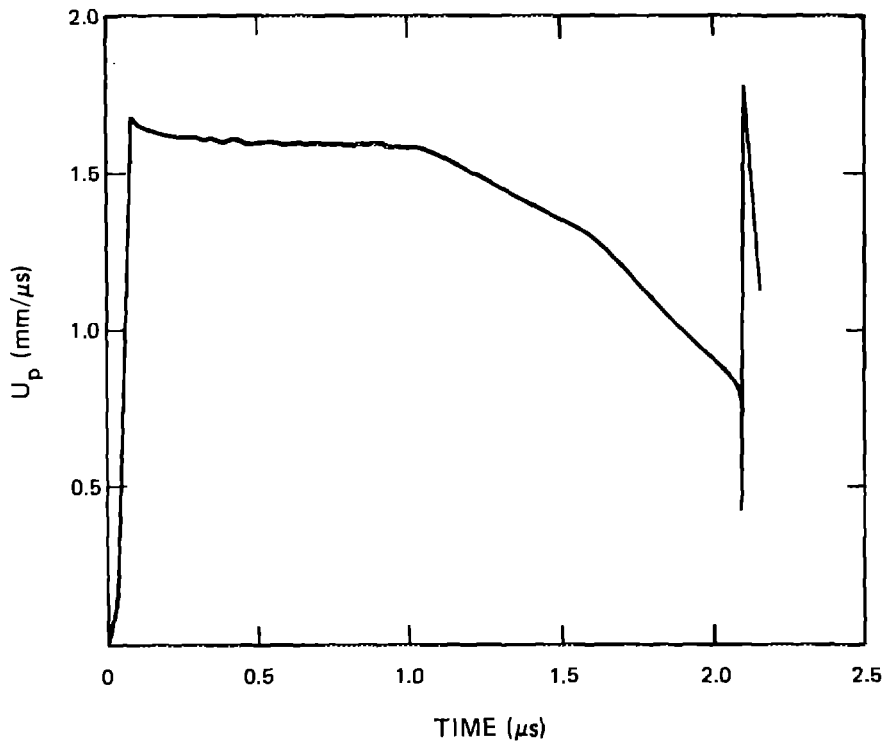

TARGET

Material: 2024 aluminum, spall strength measurement
Experiment type: ASM probe
Experimenters: J. N. Fritz and J. A. Morgan
Shot no.: M 37s1 **Date:** June 8, 1971

HE SHOT GEOMETRY

P-081 lens/101.6 mm Comp B/19.55 mm OFHC copper/
3.189 mm 2024 aluminum/6.36 mm vacuum/6.323 mm
2024 aluminum//10 mm vacuum/10.0 mm polymethyl
methacrylate//

SHOT COMPONENTS

2024 aluminum
Density: 2.785 g/cm³
 $C_L = 6.36$ mm/ μ s $C_s = 3.16$ mm/ μ s
OFHC copper
Density: 8.93 g/cm³
 $C_L = 4.76$ mm/ μ s $C_s = 2.33$ mm/ μ s

TRANSDUCER

ASM probe
Coil radius: 38.17 mm **Initial coil spacing:** 20.00 mm

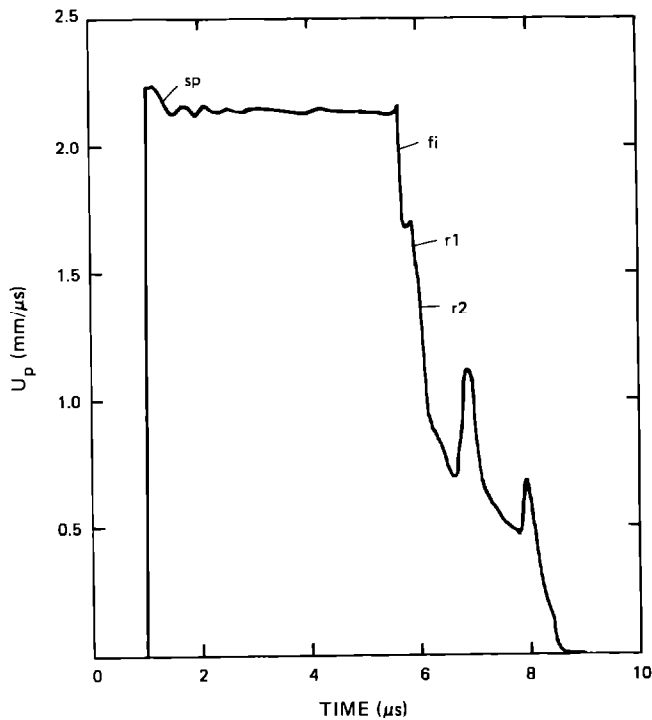

TARGET

Material: 6061 aluminum
Experiment type: Free-surface capacitor
Experimenter: J. W. Hopson
Shot no.: 56-70-46 **Date:** May 15, 1970
Thickness: 12.70 mm **Diameter:** 44.5 mm
Density: 2.703 g/cm³
C_L = 6.40 mm/μs **C_s** = 3.15 mm/μs

IMPACTOR

6061 aluminum, 6.08 mm thick, mounted on 51-mm-diam aluminum alloy projectile
Impact velocity: 0.390 mm/μs

TRANSDUCER

Free-surface capacitor
Time: Relative

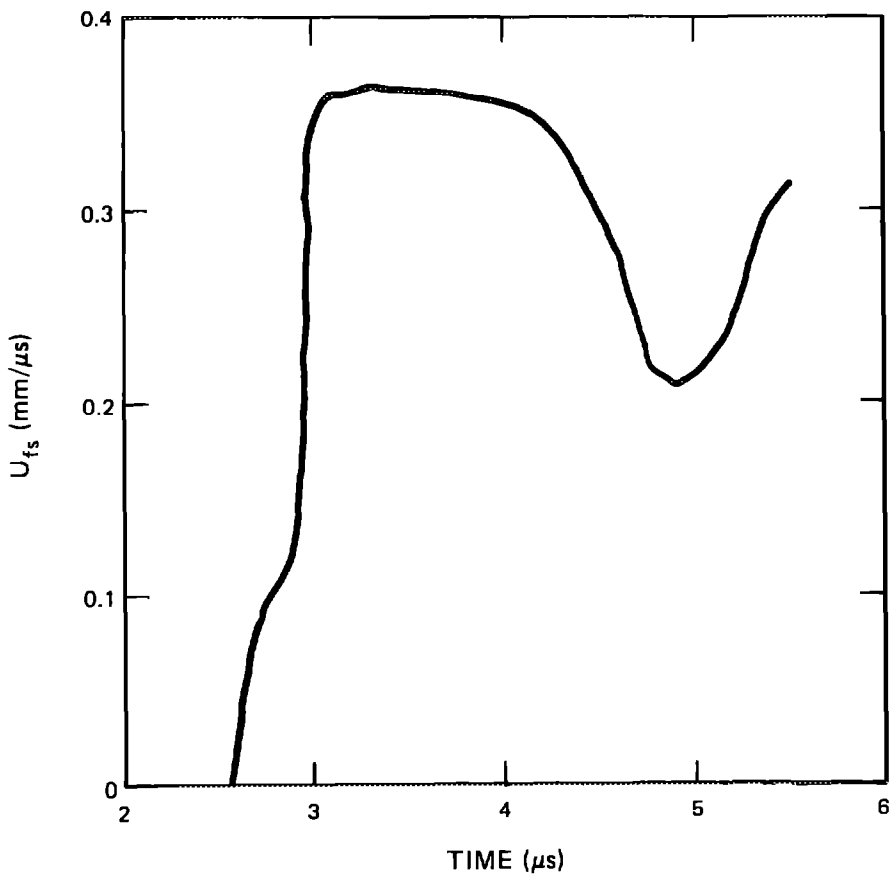

TARGET **Material:** 98.2 wt% copper with 1.8 wt% beryllium
Experiment type: Free-surface capacitor
Experimenter: J. W. Hopson
Shot no.: 56-73-28 **Date:** May 1, 1973
Thickness: 6.13 mm **Diameter:** 38.1 mm
Density: 8.33 g/cm³
C_L = 4.97 mm/μs **C_s = 2.46 mm/μs**
Heat treatment: Solution annealed and overaged

IMPACTOR OFHC copper, 2.97 mm thick, backed with low-density poly-
urethane foam, mounted on 51-mm-diam aluminum alloy
projectile

TRANSDUCER **Free-surface capacitor**
Time: Relative

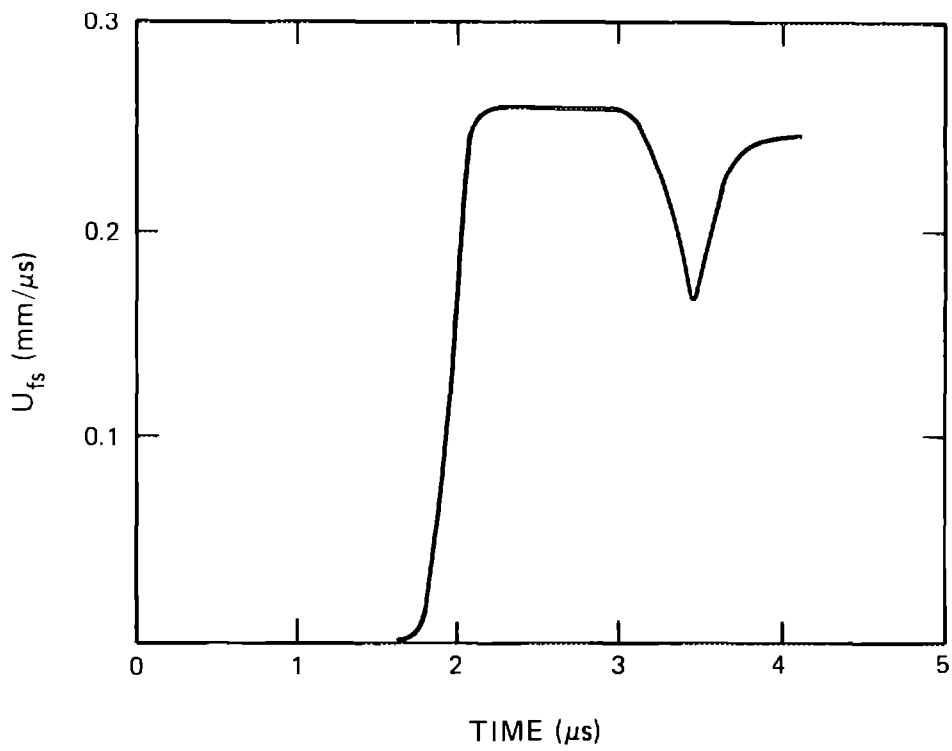

TARGET

Material: OFHC copper
Experiment type: Embedded Manganin gage
Experimenter: C. E. Morris
Shot no.: 56-78-9 **Date:** April 6, 1978
Thickness: 18.24 mm **Diameter:** 39.7 mm
Density: 8.93 g/cm³
C_L = 4.76 mm/μs **C_g** = 2.33 mm/μs

IMPACTOR

OFHC copper, 2.946 mm thick, backed with low-density polyurethane foam, mounted on 51-mm-diam aluminum alloy projectile
Impact velocity: 0.285 mm/μs

TRANSDUCER

Two-terminal, 50-Ω Manganin gage
Location from impact surface: 9.103 mm
Heat treatment: Annealed
Encapsulation: 0.041 mm polyimide on each side
Calibration: J. W. Hopson and J. W. Taylor calibration formula for Manganin gages
 $\sigma = a_1 x + b_1 x^2 + c_1 x^3$ for $x < 0.1$,
 $\sigma = a_2 + b_2 x + c_2 x^2$ for $x > 0.1$,
where $x = \Delta R/R$.
 $a_1 = 521.32$ $b_1 = -1614.86$ $c_1 = 7648.72$
 $a_2 = 6.5950$ $b_2 = 370.37$ $c_2 = 0.00$
Time: Relative

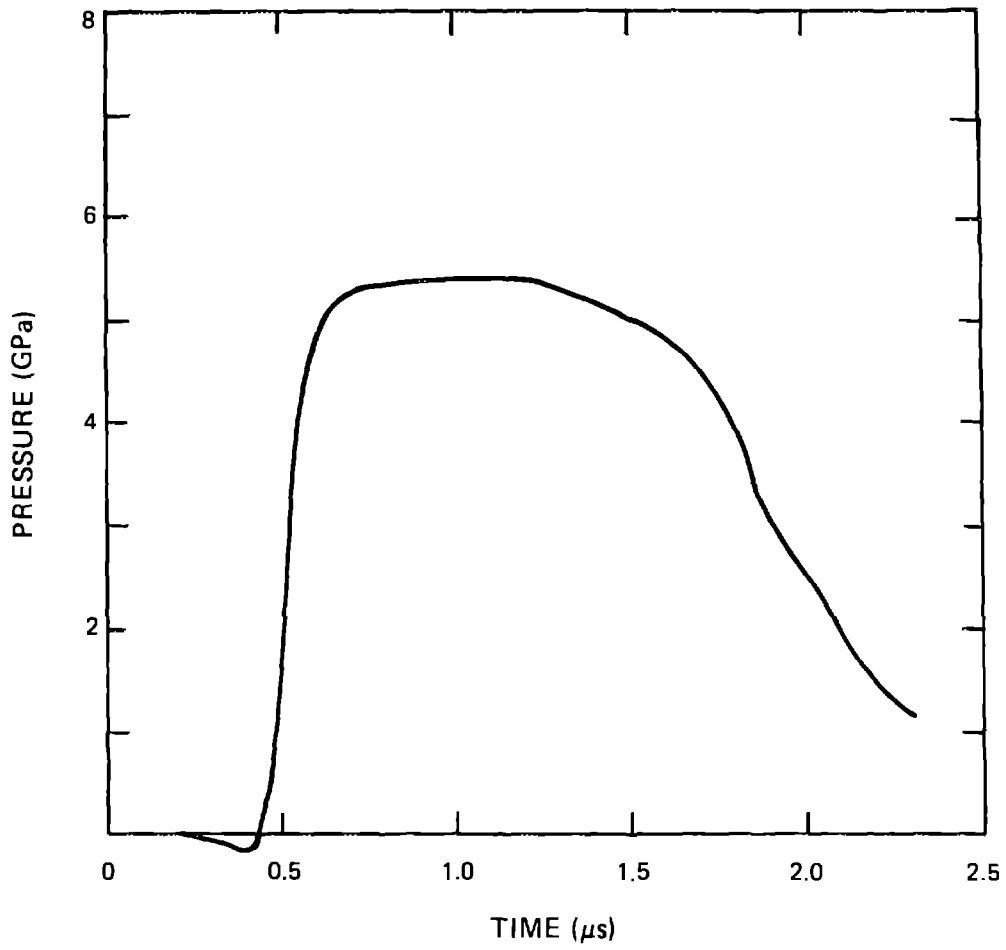

TARGET

Material: OFHC copper
Experiment type: Embedded Manganin gage
Experimenter: C. E. Morris
Shot no.: 56-78-10 **Date:** April 6, 1978
Thickness: 18.230 mm **Diameter:** 39.7 mm
Density: 8.93 g/cm³
C_L = 4.76 mm/μs **C_s** = 2.33 mm/μs

IMPACTOR

OFHC copper, 2.865 mm thick, backed with low-density polyurethane foam, mounted on 51-mm-diam aluminum alloy projectile
Impact velocity: 0.468 mm/μs

TRANSDUCER

Two-terminal, 50-Ω Manganin gage
Location from impact surface: 9.103 mm
Heat treatment: Annealed
Encapsulation: 0.041 mm polyimide on each side
Calibration: J. W. Hopson and J. W. Taylor calibration formula for Manganin gages
 $\sigma = a_1 x + b_1 x^2 + c_1 x^3$ for $x < 0.1$,
 $\sigma = a_2 + b_2 x + c_2 x^2$ for $x > 0.1$,
where $x = \Delta R/R$.
 $a_1 = 521.32$ $b_1 = -1614.86$ $c_1 = 7648.72$
 $a_2 = 6.5950$ $b_2 = 370.37$ $c_2 = 0.00$
Time: Relative

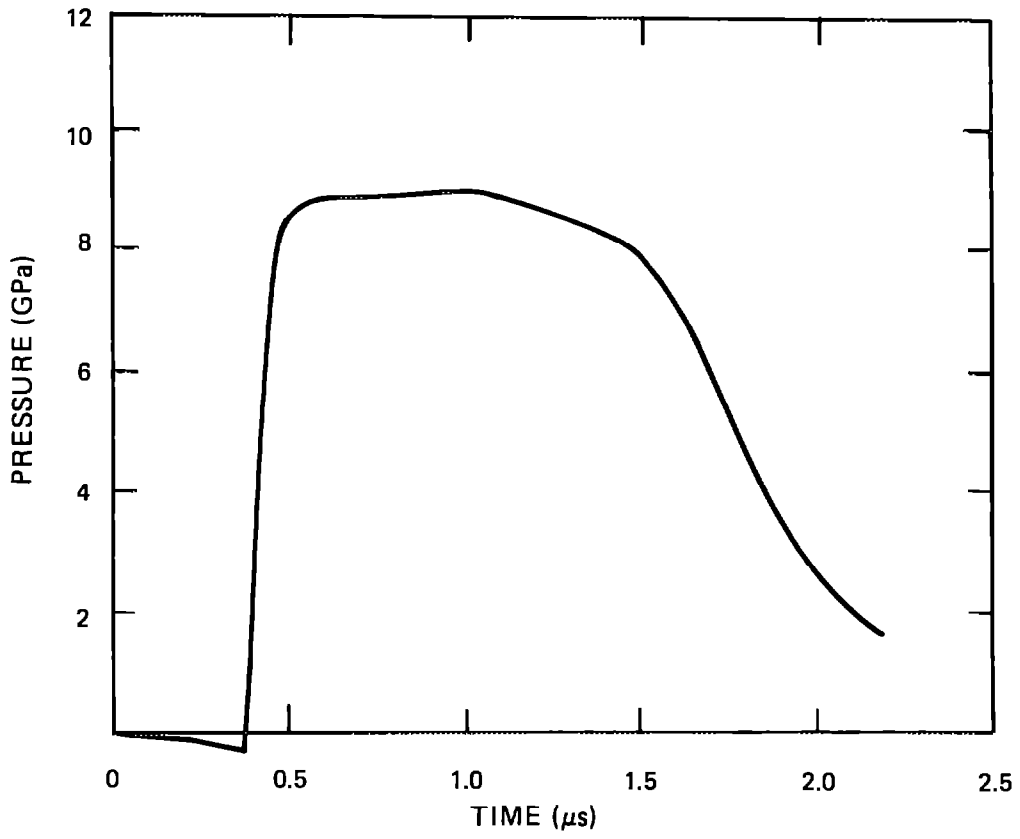

TARGET**Material:** OFHC copper**Experiment type:** Embedded Manganin gage**Experimenter:** C. E. Morris**Shot no.:** 56-78-15 **Date:** May 4, 1978**Thickness:** 18.383 mm **Diameter:** 39.7 mm**Density:** 8.93 g/cm³**C_L** = 4.76 mm/μs **C_S** = 2.33 mm/μs**IMPACTOR****OFHC copper, 2.934 mm thick, backed with low-density polyurethane foam, mounted on 51-mm-diam aluminum alloy projectile****Impact velocity:** 0.645 mm/μs**TRANSDUCER****Two-terminal, 50-Ω Manganin gage****Location from impact surface:** 9.191 mm**Heat treatment:** Annealed**Encapsulation:** 0.041 mm polyimide on each side**Calibration:** J. W. Hopson and J. W. Taylor calibration formula for Manganin gages

$$\sigma = a_1 x + b_1 x^2 + c_1 x^3 \text{ for } x < 0.1,$$

$$\sigma = a_2 + b_2 x + c_2 x^2 \text{ for } x > 0.1,$$

where $x = \Delta R/R$.

$$a_1 = 521.32 \quad b_1 = -1614.86 \quad c_1 = 7648.72$$

$$a_2 = 6.5950 \quad b_2 = 370.37 \quad c_2 = 0.00$$

Time: Relative

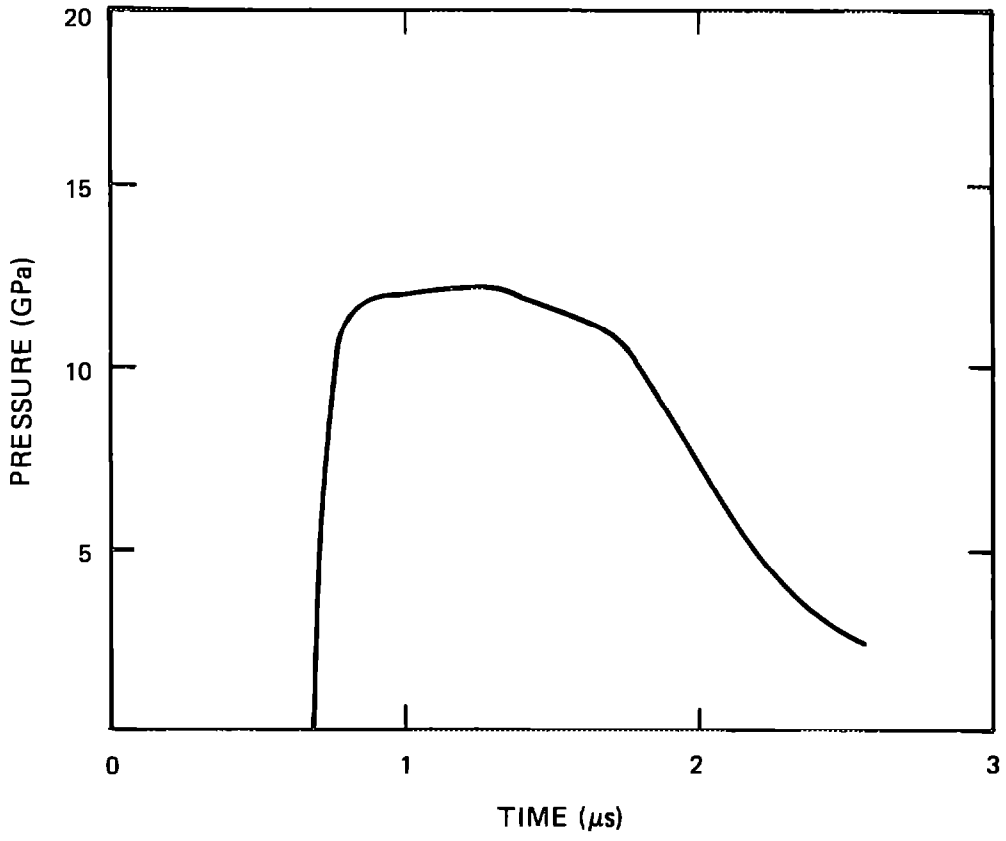

TARGET

Material: OFHC copper
Experiment type: Embedded Manganin gage
Experimenter: C. E. Morris
Shot no.: 56-78-16 **Date:** May 4, 1978
Thickness: 18.380 mm **Diameter:** 39.7 mm
Density: 8.93 g/cm³
C_L = 4.76 mm/μs **C_s** = 2.33 mm/μs

IMPACTOR

OFHC copper, 2.959 mm thick, backed with tungsten carbide (ρ = 18.84 g/cm³), mounted on 51-mm-diam aluminum alloy projectile
Impact velocity: 0.311 mm/μs

TRANSDUCER

Two-terminal, 50-Ω Manganin gage
Location from impact surface: 9.193 mm
Heat treatment: Annealed
Encapsulation: 0.041 mm polyimide on both sides
Calibration: J. W. Hopson and J. W. Taylor calibration formula for Manganin gages
 $\sigma = a_1 x + b_1 x^2 + c_1 x^3$ for $x < 0.1$,
 $\sigma = a_2 + b_2 x + c_2 x^2$ for $x > 0.1$,
where $x = \Delta R/R$.
a₁ = 521.32 **b₁** = -1614.86 **c₁** = 7648.72
a₂ = 6.5950 **b₂** = 370.37 **c₂** = 0.00
Time: Relative

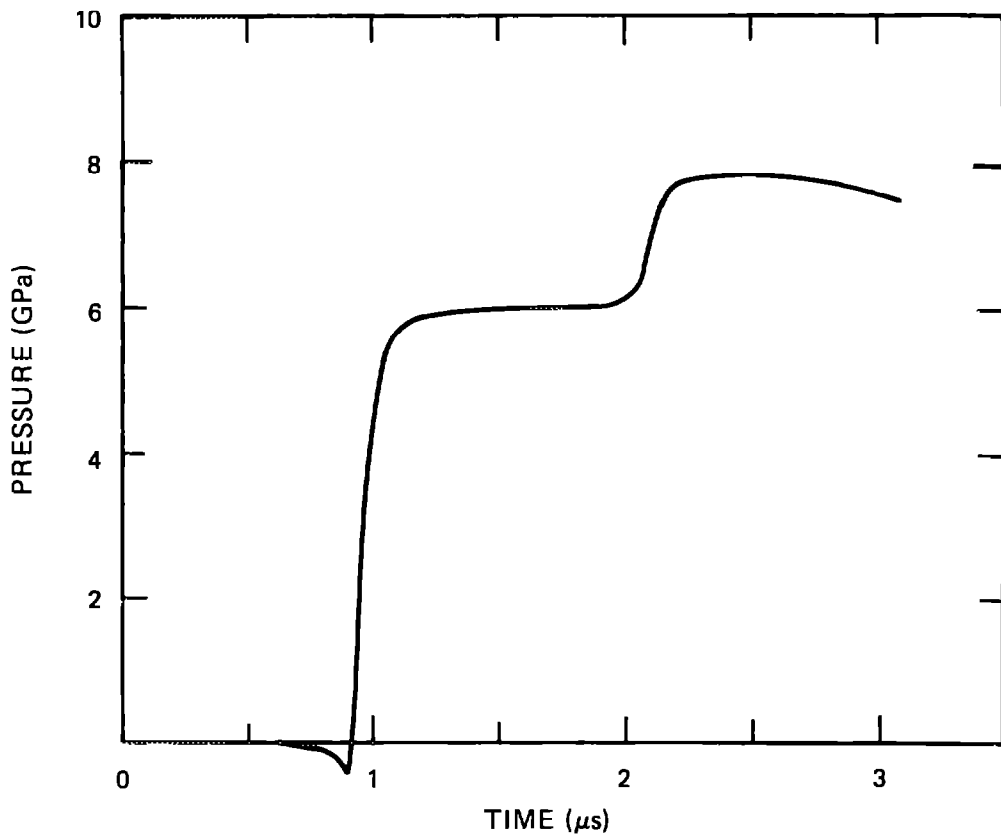

TARGET **Material:** OFHC copper
Experiment type: Embedded Manganin gage
Experimenter: C. E. Morris
Shot no.: 56-78-17 **Date:** May 8, 1978
Thickness: 18.382 mm **Diameter:** 39.7 mm
Density: 8.93 g/cm³
C_L = 4.76 mm/μs **C_s** = 2.33 mm/μs

IMPACTOR OFHC copper, 2.952 mm thick, backed with tungsten carbide
(ρ = 18.83 g/cm³), mounted on 51-mm-diam aluminum alloy
projectile
Impact velocity: 0.488 mm/μs

TRANSDUCER Two-terminal, 50-Ω Manganin gage
Location from impact surface: 9.150 mm
Heat treatment: Annealed
Encapsulation: 0.041 mm polyimide on both sides
Calibration: J. W. Hopson and J. W. Taylor calibration formula
for Manganin gages
 $\sigma = a_1 x + b_1 x^2 + c_1 x^3$ for $x < 0.1$,
 $\sigma = a_2 + b_2 x + c_2 x^2$ for $x > 0.1$,
where $x = \Delta R/R$.
a₁ = 521.32 **b₁** = -1614.86 **c₁** = 7648.72
a₂ = 6.5950 **b₂** = 370.37 **c₂** = 0.00
Time: Relative

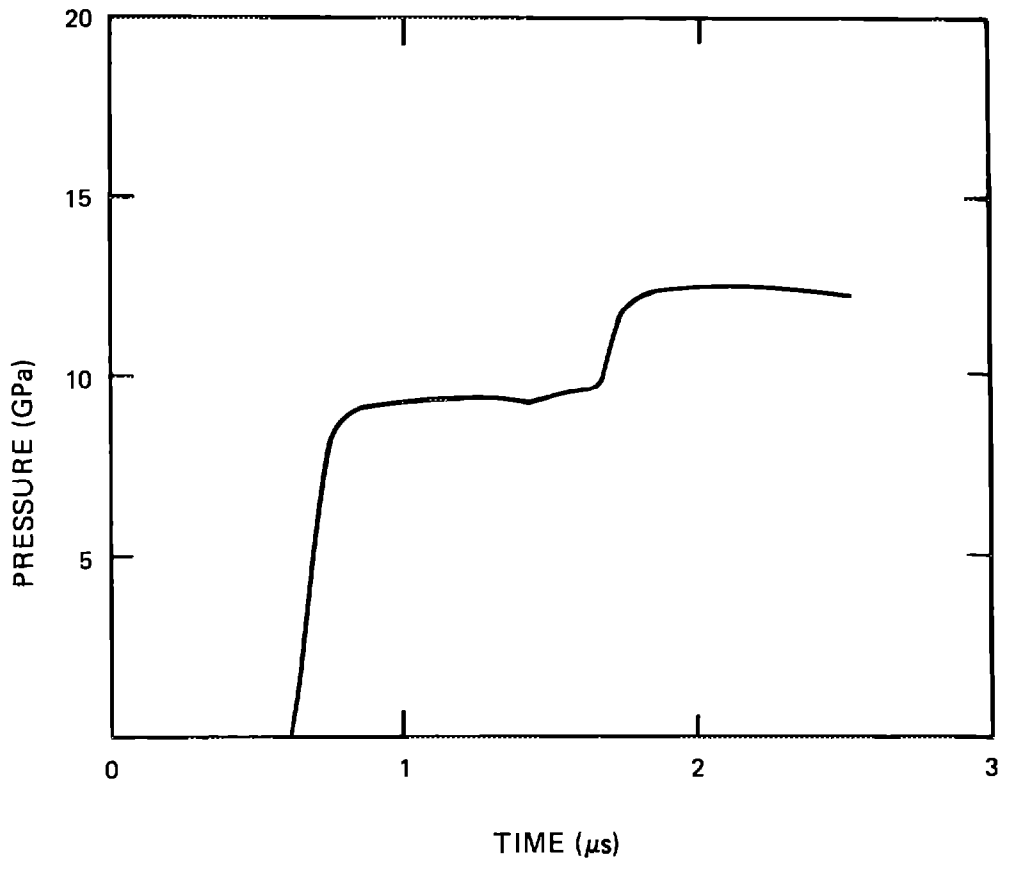

TARGET

Material: OFHC copper
Experiment type: Embedded Manganin gage
Experimenter: C. E. Morris
Shot no.: 56-78-18 **Date:** May 9, 1978
Thickness: 18.344 mm **Diameter:** 39.7 mm
Density: 8.93 g/cm³
C_L = 4.76 mm/μs **C_s** = 2.33 mm/μs

IMPACTOR

OFHC copper, 2.922 mm thick, backed with tungsten carbide (ρ = 18.04 g/cm³), mounted on 51-mm-diam aluminum alloy projectile
Impact velocity: 0.612 mm/μs

TRANSDUCER

Two-terminal, 50-Ω Manganin gage
Location from impact surface: 9.161 mm
Heat treatment: Annealed
Encapsulation: 0.041 polyimide on both sides
Calibration: J. W. Hopson and J. W. Taylor calibration formula for Manganin gages
 $\sigma = a_1 x + b_1 x^2 + c_1 x^3$ for $x < 0.1$,
 $\sigma = a_2 + b_2 x + c_2 x^2$ for $x > 0.1$,
where $x = \Delta R/R$.
a₁ = 521.32 **b₁** = -1614.86 **c₁** = 7648.72
a₂ = 6.5950 **b₂** = 370.37 **c₂** = 0.00
Time: Relative

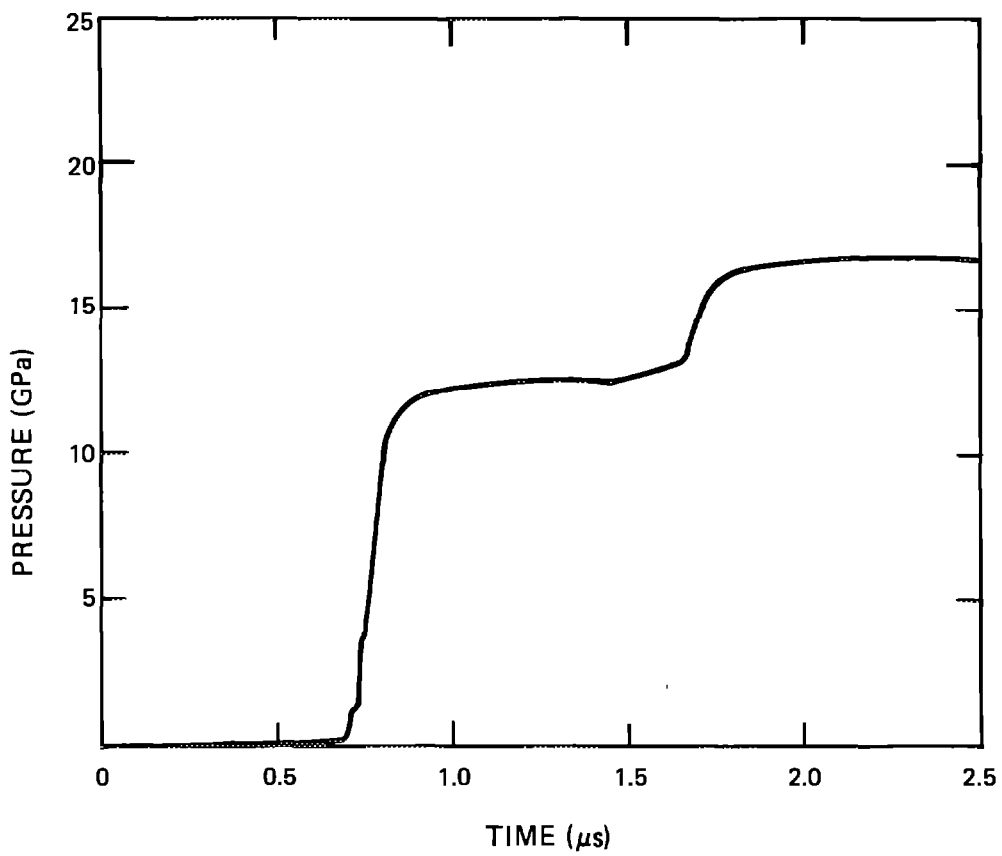

TARGET

Material: OFHC copper
Experiment type: Embedded Manganin gage
Experimenter: C. E. Morris
Shot no.: 56-78-70 **Date:** October 17, 1978
Thickness: 18.254 mm **Diameter:** 39.7 mm
Density: 8.93 g/cm³
C_L = 4.76 mm/μs **C_s** = 2.33 mm/μs
Heat treatment: Fully annealed

IMPACTOR

OFHC copper, 3.005 mm thick, backed with low-density polyurethane foam, mounted on 51-mm-diam aluminum alloy projectile
Impact velocity: 0.540 mm/μs

TRANSDUCER

Two-terminal, 50-Ω Manganin gage
Location from impact surface: 9.673 mm
Heat treatment: Annealed
Encapsulation: 0.544 mm Al₂O₃ [1102] on both sides
Calibration: J. W. Hopson and J. W. Taylor calibration formula for Manganin gages
 $\sigma = a_1 x + b_1 x^2 + c_1 x^3$ for $x < 0.1$,
 $\sigma = a_2 + b_2 x + c_2 x^2$ for $x > 0.1$,
where $x = \Delta R/R$.
 $a_1 = 521.32$ $b_1 = -1614.86$ $c_1 = 7648.72$
 $a_2 = 6.5950$ $b_2 = 370.37$ $c_2 = 0.00$
Time: Relative

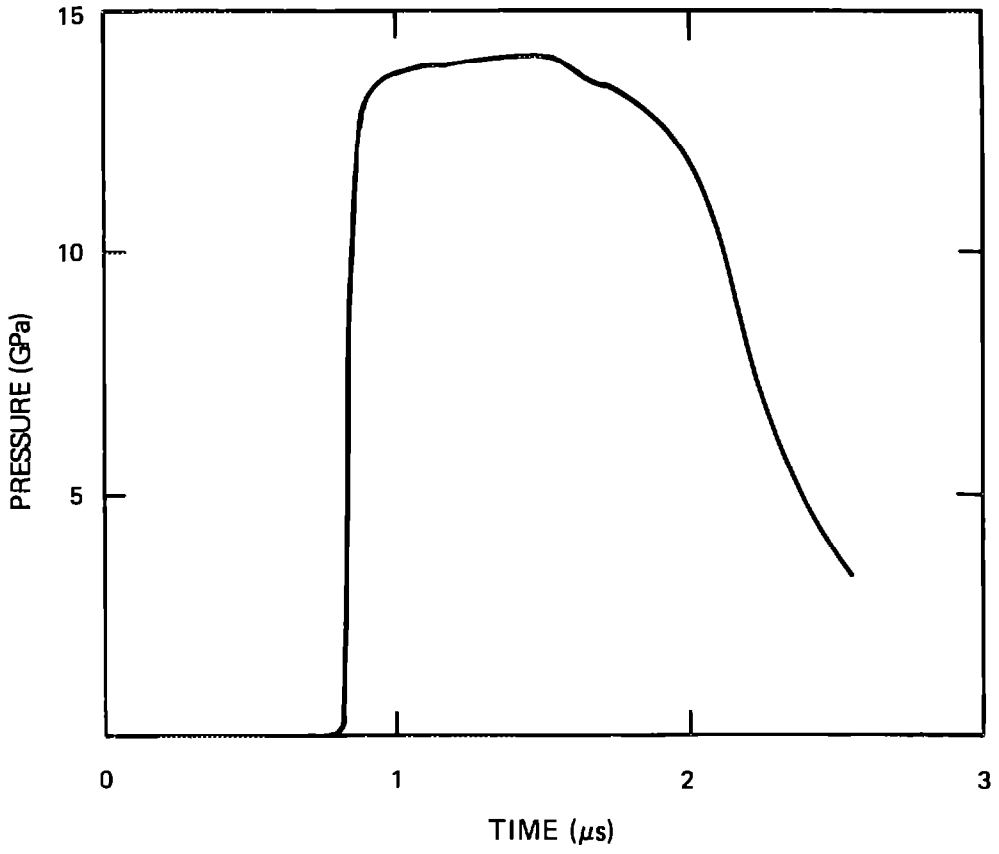

TARGET

Material: OFHC copper
Experiment type: ASM probe
Experimenters: C. E. Morris and J. N. Fritz
Shot no.: 88S79 **Date:** December 23, 1980

HE SHOT GEOMETRY

P-120 lens/102 mm TNT/6.35 mm air/6.370 mm OFHC copper/25 mm HE/12.985 mm OFHC copper//epoxy/7.891 mm dense glass//

SHOT COMPONENTS

OFHC copper
Density: 8.93 g/cm³
 $C_L = 4.76 \text{ mm}/\mu\text{s}$ $C_g = 2.33 \text{ mm}/\mu\text{s}$
Dense glass
Density: 5.197 g/cm³

TRANSDUCER

ASM probe
Coil radius: 19.143 mm **Initial coil spacing:** 8.484 mm

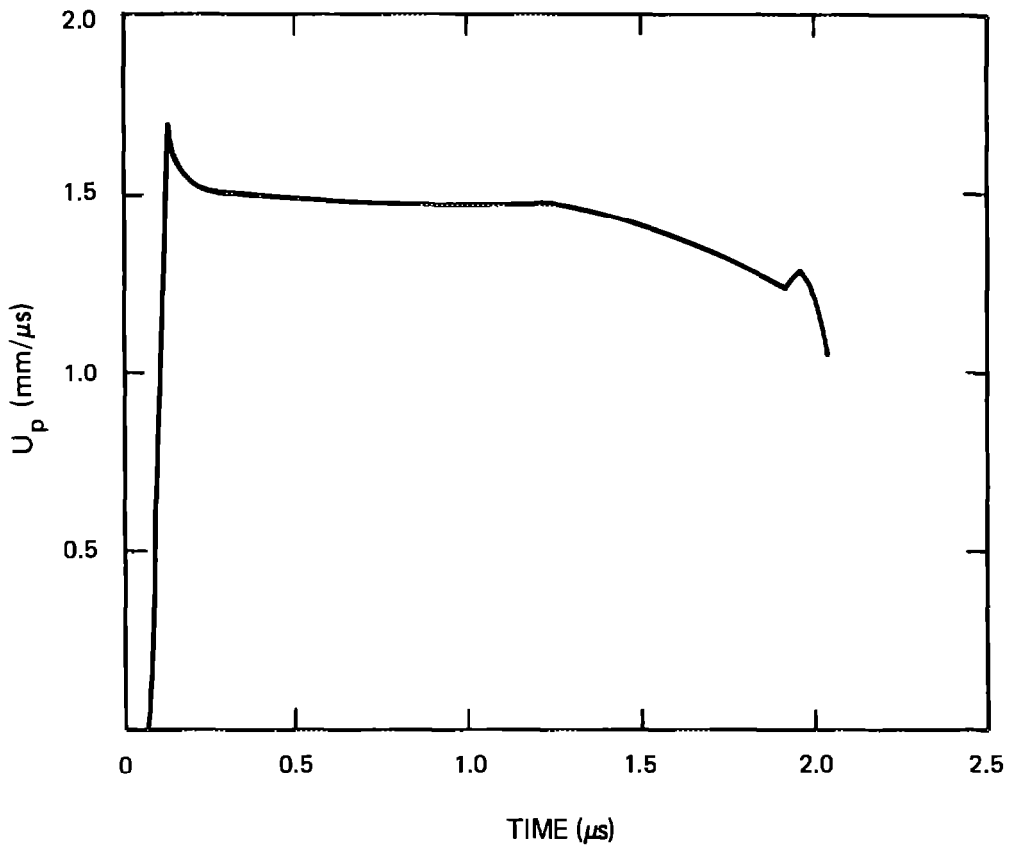

TARGET

Material: OFHC copper
Experiment type: ASM probe
Experimenters: C. E. Morris and J. N. Fritz
Shot no.: 88S80 **Date:** December 24, 1980

HE SHOT GEOMETRY

P-120 lens/102 mm Comp B/6.35 mm air/0.25 mm polyethylene/6.401 mm OFHC copper/25 mm HE/12.984 mm OFHC copper//epoxy/7.844 mm dense glass//

SHOT COMPONENTS

OFHC copper
Density: 8.93 g/cm³
 $C_L = 4.76$ mm/ μ s $C_S = 2.33$ mm/ μ s
Dense glass
Density: 5.204 g/cm³

TRANSDUCER

ASM probe
Coil radius: 19.120 mm **Initial coil spacing:** 8.443 mm

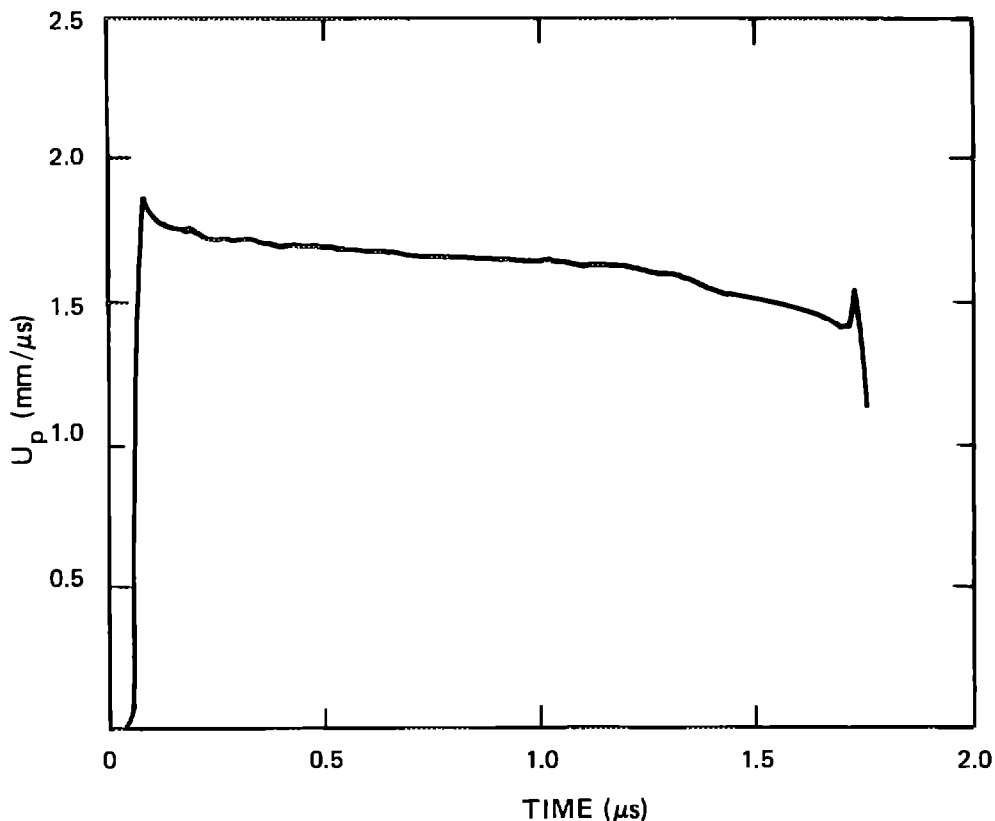

TARGET

Material: OFHC copper
Experiment type: ASM probe
Experimenters: C. E. Morris and J. N. Fritz
Shot no.: 88S81 **Date:** January 21, 1981

HE SHOT GEOMETRY

P-120 lens/203 mm PBX 9501/6.35 mm air/0.25 mm polyethylene/5.131 mm OFHC copper/25 mm HE/12.992 mm OFHC copper//epoxy/7.737 mm dense glass//

SHOT COMPONENTS

OFHC copper
Density: 8.93 g/cm³
 $C_L = 4.76$ mm/ μ s $C_S = 2.33$ mm/ μ s
Dense glass
Density: 5.197 g/cm³

TRANSDUCER

ASM probe
Coil radius: 25.462 mm **Initial coil spacing:** 8.325 mm

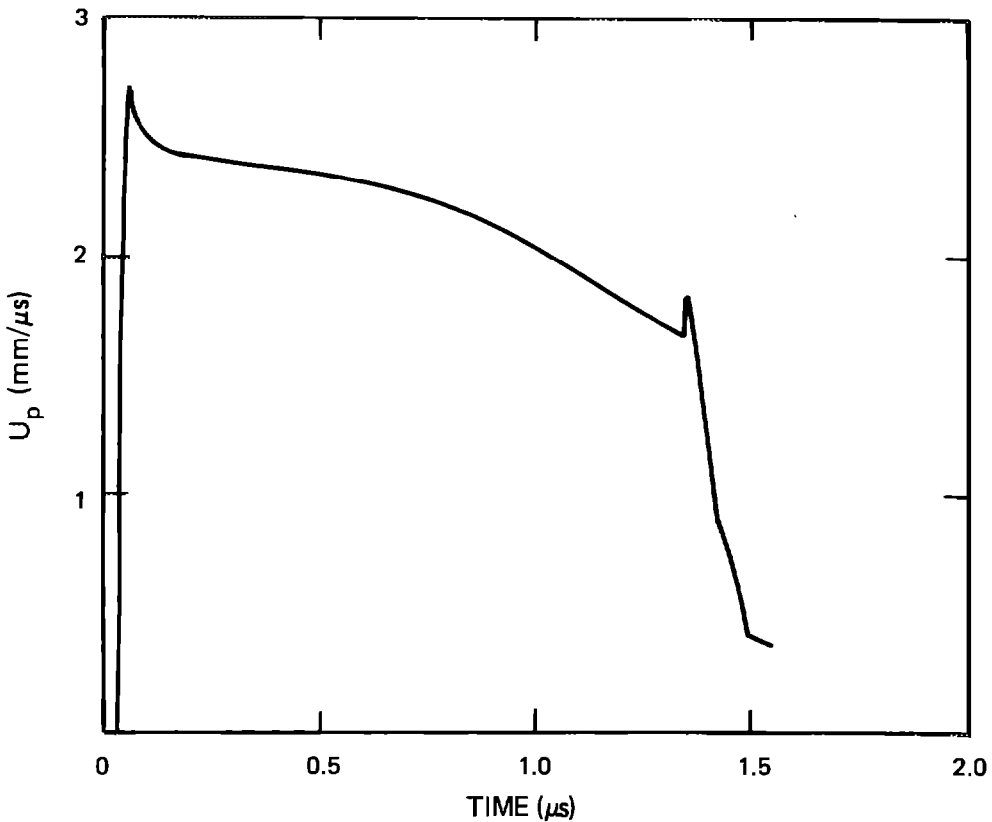

TARGET

Material: OFHC copper
Experiment type: ASM probe
Experimenters: C. E. Morris and J. N. Fritz
Shot no.: 88S82 **Date:** January 22, 1981

HE SHOT GEOMETRY

P-120 lens/203 mm PBX 9501/6.35 mm air/0.25 mm polyethylene/3.155 mm OFHC copper/8.980 mm OFHC copper//epoxy/5.523 mm dense glass//

SHOT COMPONENTS

OFHC copper
Density: 8.93 g/cm³
 $C_L = 4.76$ mm/ μ s $C_S = 2.33$ mm/ μ s
Dense glass
Density: 5.163 g/cm³

TRANSDUCER

ASM probe
Coil radius: 19.122 mm **Initial coil spacing:** 6.114 mm

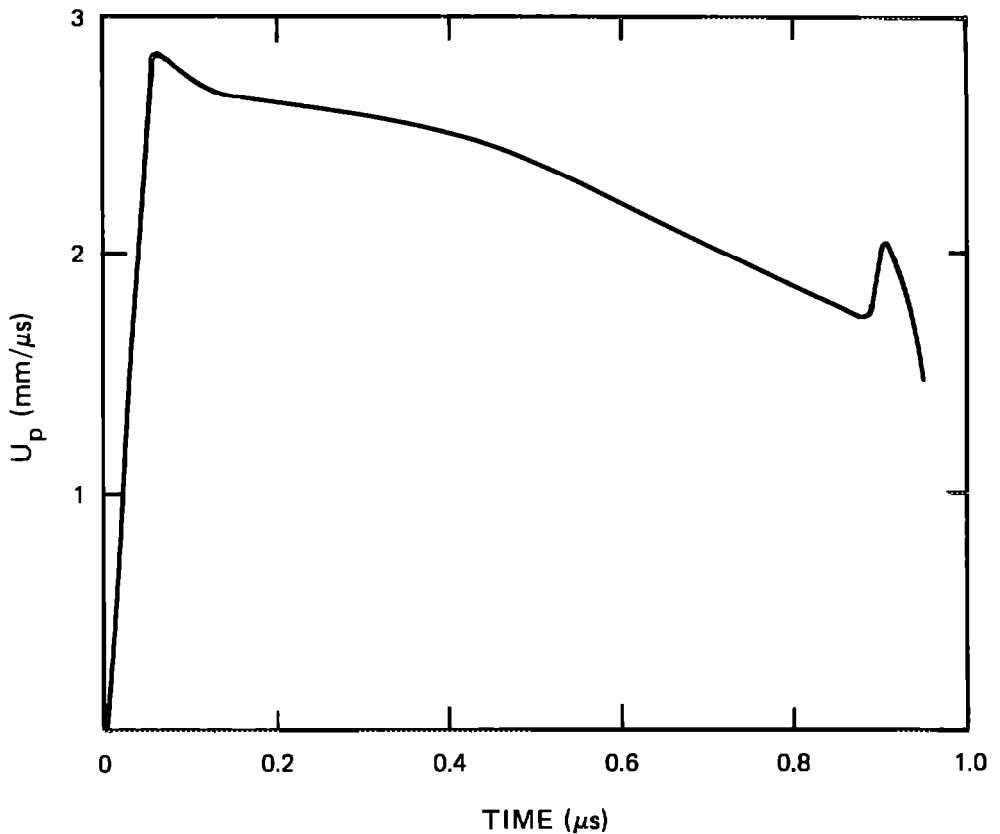

TARGET

Material: 98 wt% gold with 2 wt% copper
Experiment type: Free-surface capacitor
Experimenter: J. W. Hopson
Shot no.: 56-73-29 **Date:** May 1, 1973
Thickness: 8.13 mm **Diameter:** 38.1 mm
Density: 18.73 g/cm³
C_L = 3.36 mm/μs **C_S** = 1.21 mm/μs
Heat treatment: Annealed

IMPACTOR

OFHC copper, 4.83 mm thick, backed with low-density polyurethane foam, mounted on 51-mm-diam aluminum alloy projectile

TRANSDUCER

Free-surface capacitor
Time: Relative

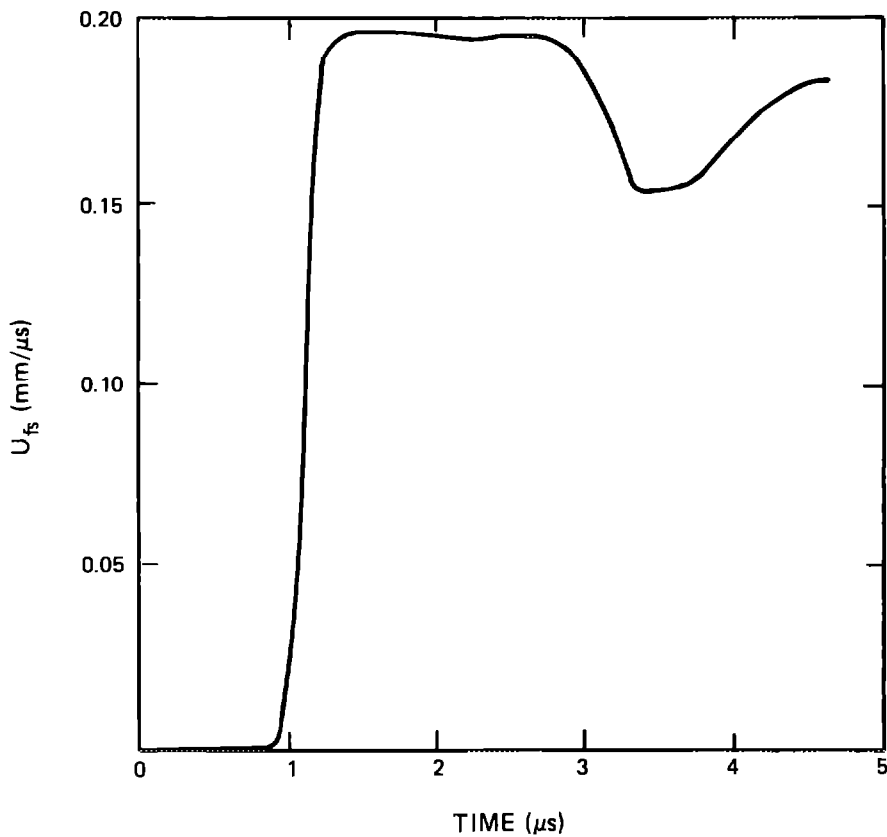

TARGET **Material:** Iron-manganese alloy
 Experiment type: Free-surface capacitor
 Experimenter: J. W. Taylor
 Shot no.: 56-66-366 **Date:** January 5, 1966

IMPACTOR Armco iron, mounted on aluminum alloy projectile

TRANSDUCER Free-surface capacitor
 Time: Relative

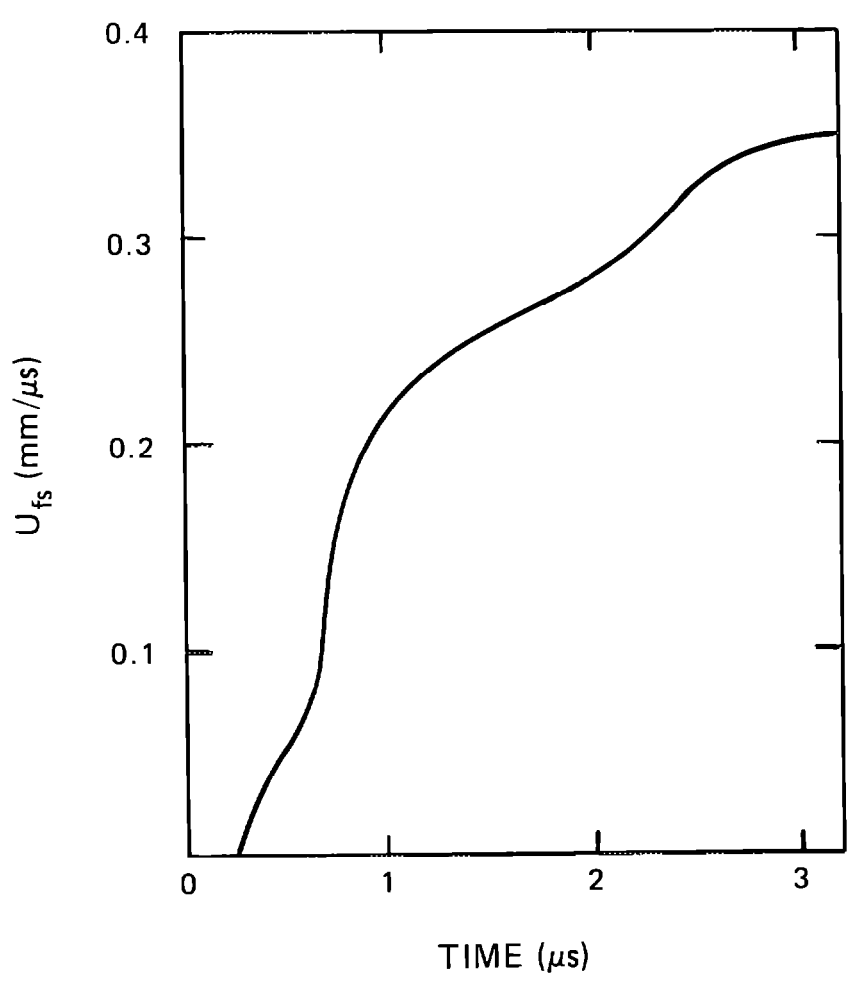

TARGET

Material: 97 wt% lead with 3 wt% antimony
Experiment type: Free-surface capacitor
Experimenter: J. W. Hopson
Shot no.: 56-73-4 **Date:** February 8, 1973
Thickness: 9.51 mm **Diameter:** 38.1 mm
Density: 11.16 g/cm³
C_L = 5.89 mm/μs **C_S** = 4.0 mm/μs
Heat treatment: Rolled and annealed

IMPACTOR

OFHC copper, 4.93 mm thick, mounted on 51-mm-diam aluminum alloy projectile
Impact velocity: 0.219 mm/μs

TRANSDUCER

Free-surface capacitor
Time: Relative

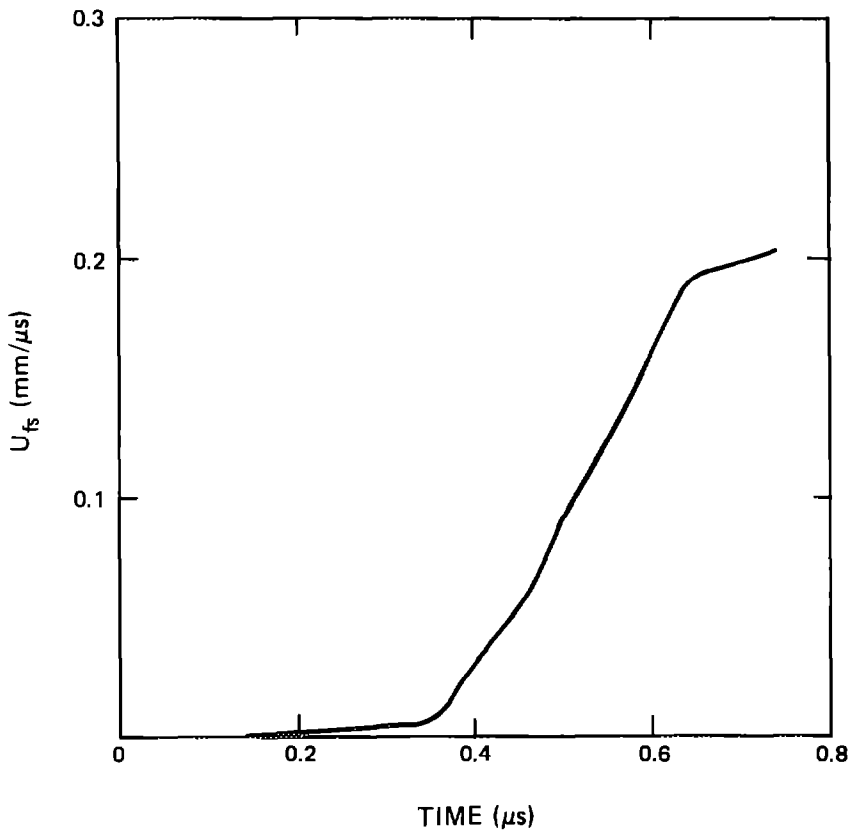

TARGET

Material: Magnesium alloy, AZ31 B
Experiment type: Free-surface capacitor
Experimenter: J. W. Taylor
Reference: R. G. McQueen, S. P. Marsh, J. W. Taylor, J. N. Fritz,
and W. J. Carter (1970)
Shot no.: 56-67-460 **Date:** November 2, 1967
Thickness: 12.7 mm **Diameter:** 38.1 mm
Density: 1.78 g/cm³
 $C_L = 5.73 \text{ mm}/\mu\text{s}$ $C_s = 3.05 \text{ mm}/\mu\text{s}$

IMPACTOR

2024 aluminum, 3.05 mm thick, backed with low-density poly-
urethane foam, mounted on 51-mm-diam aluminum alloy
projectile
Impact velocity: 0.400 mm/ μs

TRANSDUCER

Free-surface capacitor
Time: Relative

NOTES

Shots 56-67-460 and 56-67-461 are sequential overtaking unloading
wave profiles with varied driver thicknesses.

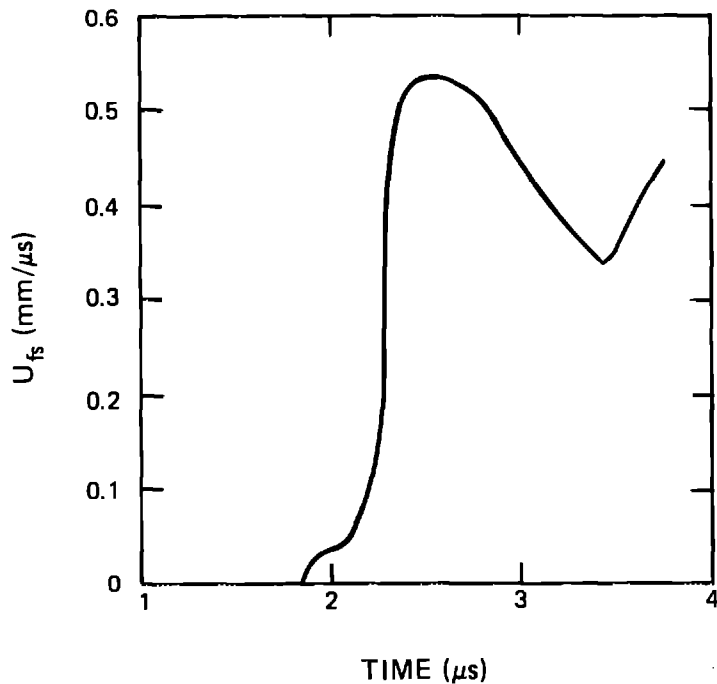

TARGET

Material: Magnesium alloy, AZ31 B
Experiment type: Free-surface capacitor
Experimenter: J. W. Taylor
Reference: R. G. McQueen, S. P. Marsh, J. W. Taylor, J. N. Fritz, and W. J. Carter (1970)
Shot no.: 56-67-461 **Date:** November 2, 1967
Thickness: 12.7 mm **Diameter:** 38.1 mm
Density: 1.78 g/cm³
C_L = 5.73 mm/μs **C_g** = 3.05 mm/μs

IMPACTOR

2024 aluminum, 0.81 mm thick, backed with low-density polyurethane foam, mounted on 51-mm-diam aluminum alloy projectile
Impact velocity: 0.400 mm/μs

TRANSDUCER

Free-surface capacitor
Time: Relative

NOTES

Shots 56-67-460 and 56-67-461 are sequential overtaking unloading wave profiles with varied driver thicknesses.

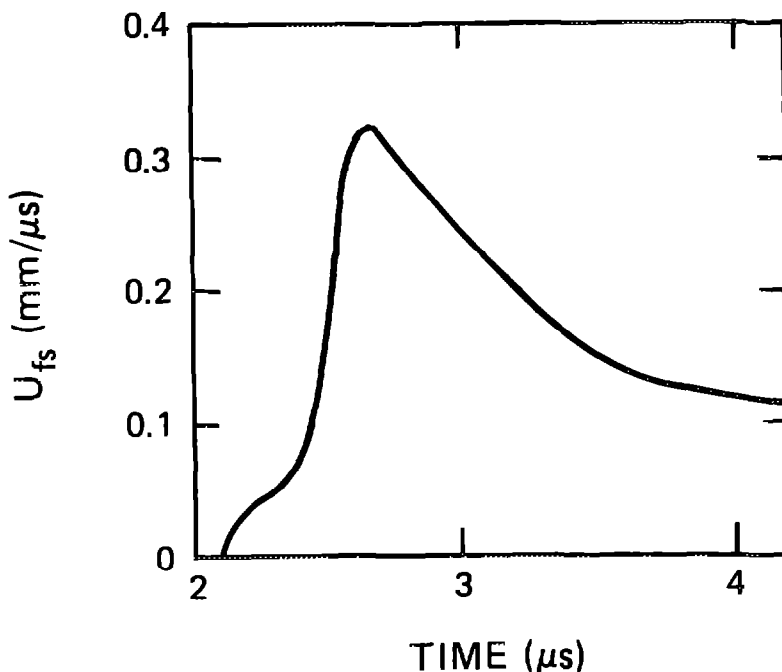

TARGET

Material: Molybdenum carbide, $\text{MoC}_{0.60}$
Experiment type: Free-surface capacitor
Experimenter: J. W. Hopson
Shot no.: 8B623 **Date:** May 6, 1969

HE SHOT SYSTEM

P-080 lens/102 mm baratol/2024 aluminum base plate/
7.24 mm molybdenum carbide

SHOT COMPONENTS

Molybdenum carbide, $\text{MoC}_{0.60}$
Density: 8.94 g/cm^3

TRANSDUCER

Free-surface capacitor
Time: Relative

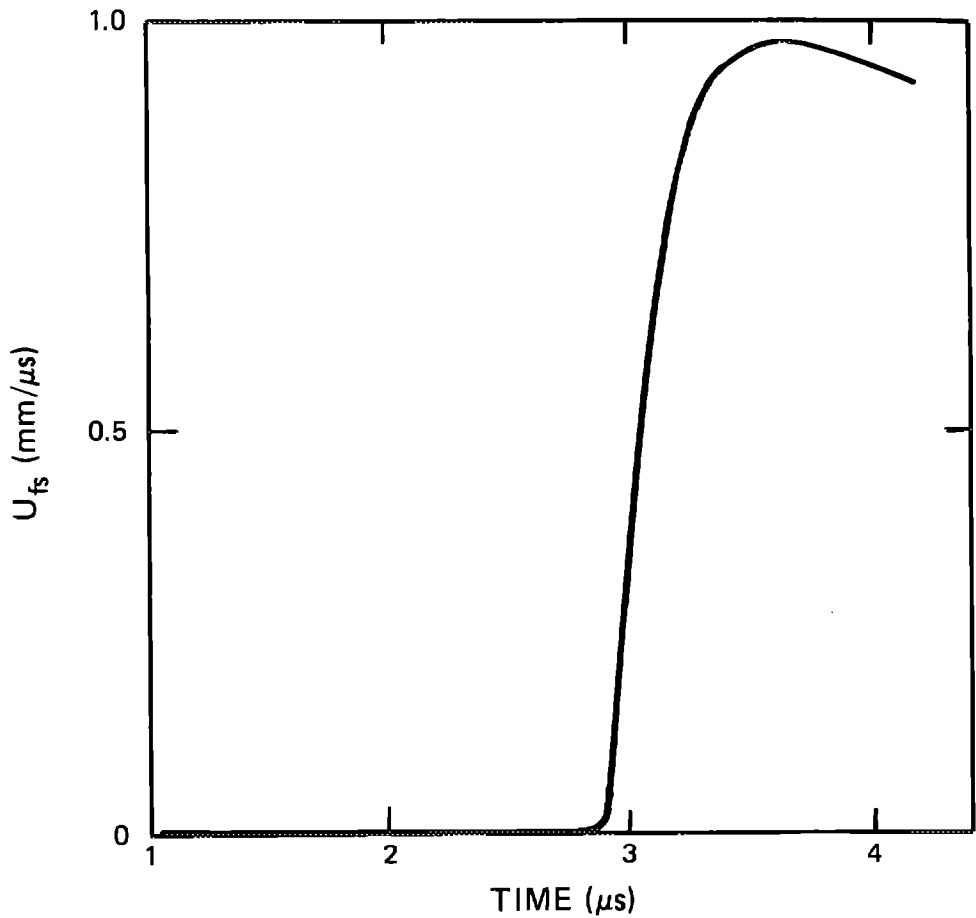

TARGET **Material:** 50 wt% molybdenum with 50 wt% rhenium
Experiment type: Free-surface capacitor
Experimenter: J. W. Hopson
Shot no.: 56-73-31 **Date:** May 2, 1973
Thickness: 8.50 mm **Diameter:** 38.1 mm
Density: 14.633 g/cm³
C_L = 5.84 mm/μs **C_s =** 3.10 mm/μs
Heat treatment: Annealed at 1650°C

IMPACTOR OFHC copper, 2.97 mm thick, backed with low-density polyurethane foam, mounted on 51-mm-diam aluminum alloy projectile

TRANSDUCER Free-surface capacitor
Time: Relative

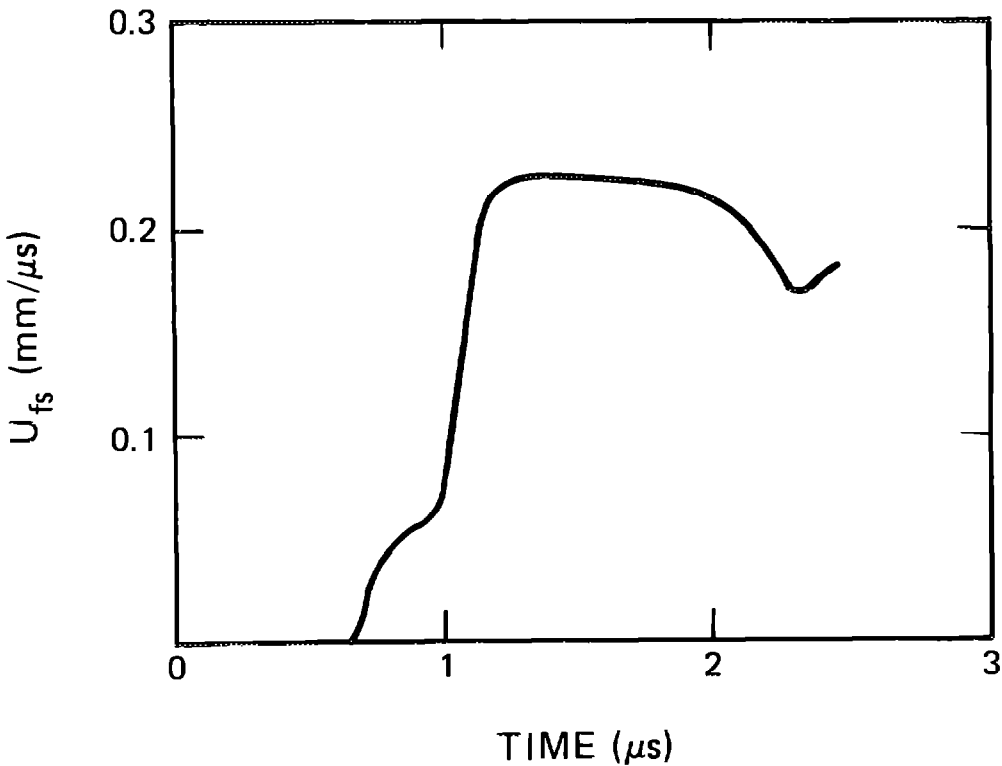

TARGET **Material:** Almar 362 steel
Experiment type: Free-surface capacitor
Experimenters: J. W. Hopson and J. W. Taylor
Shot no.: 56-71-36 **Date:** October 13, 1971
Thickness: 6.42 mm **Diameter:** 38.1 mm
Density: 7.78 g/cm³
C_L = 5.68 mm/μs **C_s** = 3.18 mm/μs

IMPACTOR Steel, 6.06 mm thick, backed with low-density polyurethane foam,
mounted on 51-mm-diam aluminum alloy projectile
Impact velocity: 0.319 mm/μs

TRANSDUCER Free-surface capacitor
Time: Relative

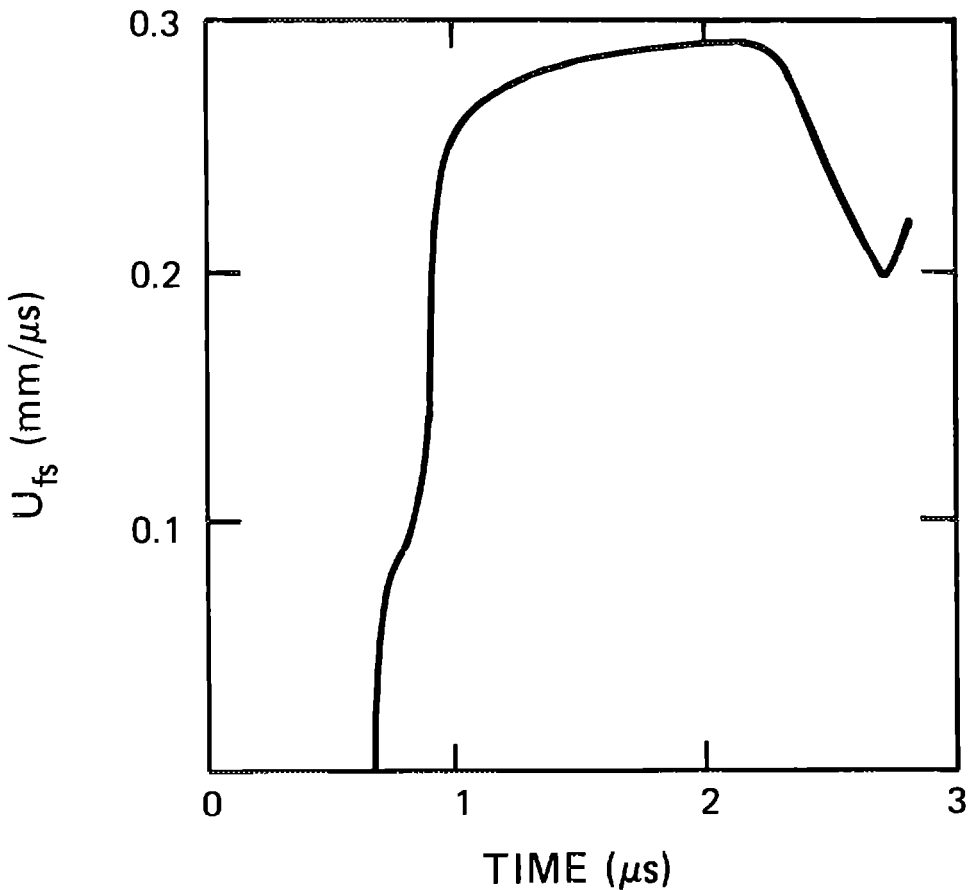

TARGET

Material: A-256 Austenitic stainless steel
Experiment type: Free-surface capacitor
Experimenter: J. W. Hopson
Shot no.: 56-73-3 **Date:** February 5, 1973
Thickness: 9.53 mm **Diameter:** 38.1 mm
Density: 7.96 g/cm³
 $C_L = 5.70$ mm/ μ s $C_S = 3.14$ mm/ μ s
Heat treatment: Solution annealed and aged at 1325°F for 16 hours

IMPACTOR

OFHC copper, 2.972 mm thick, backed with low-density polyurethane foam, mounted on 51-mm-diam aluminum alloy projectile
Impact velocity: 0.271 mm/ μ s

TRANSDUCER

Free-surface capacitor
Time: Relative

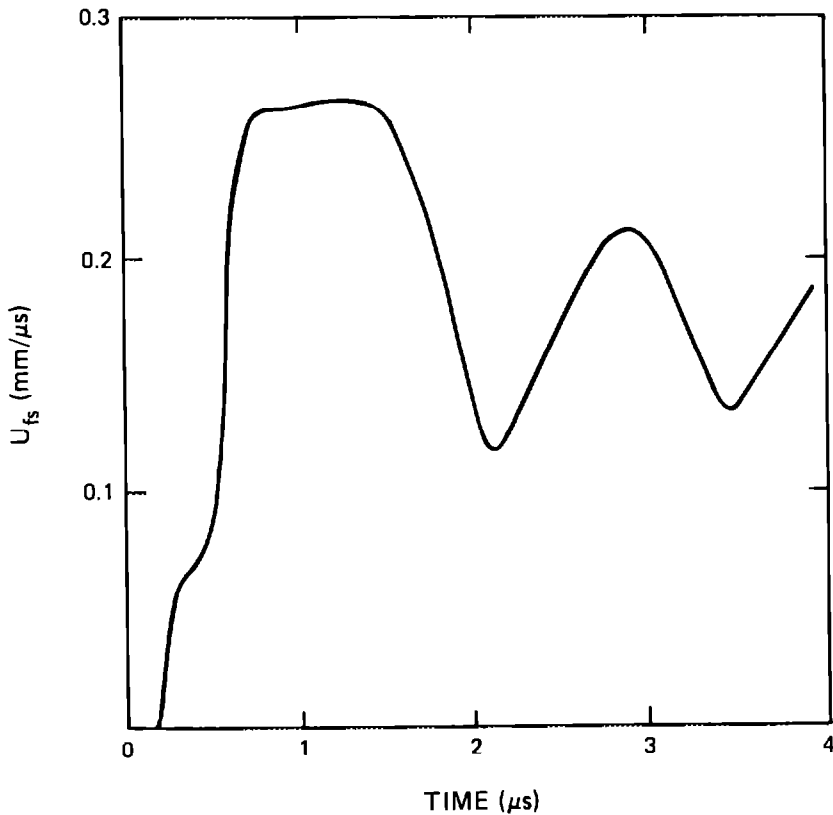

TARGET**Material:** Fansteel 77**Experiment type:** Free-surface capacitor**Experimenter:** J. W. Taylor**Reference:** R. G. McQueen, S. P. Marsh, J. W. Taylor, J. N. Fritz,
and W. J. Carter (1970)**Shot no.:** 56-67-427 **Date:** February 5, 1967**Thickness:** 12.70 mm **Diameter:** 38.1 mm**Density:** 17.48 g/cm³ **C_L** = 5.10 mm/ μ s **C_S** = 3.95 mm/ μ s**Hardness:** Rc 35**IMPACTOR**Tantalum, 3.18 mm thick, backed with low-density polyurethane
foam, mounted on 51-mm-diam aluminum alloy projectile**TRANSDUCER**

Free-surface capacitor

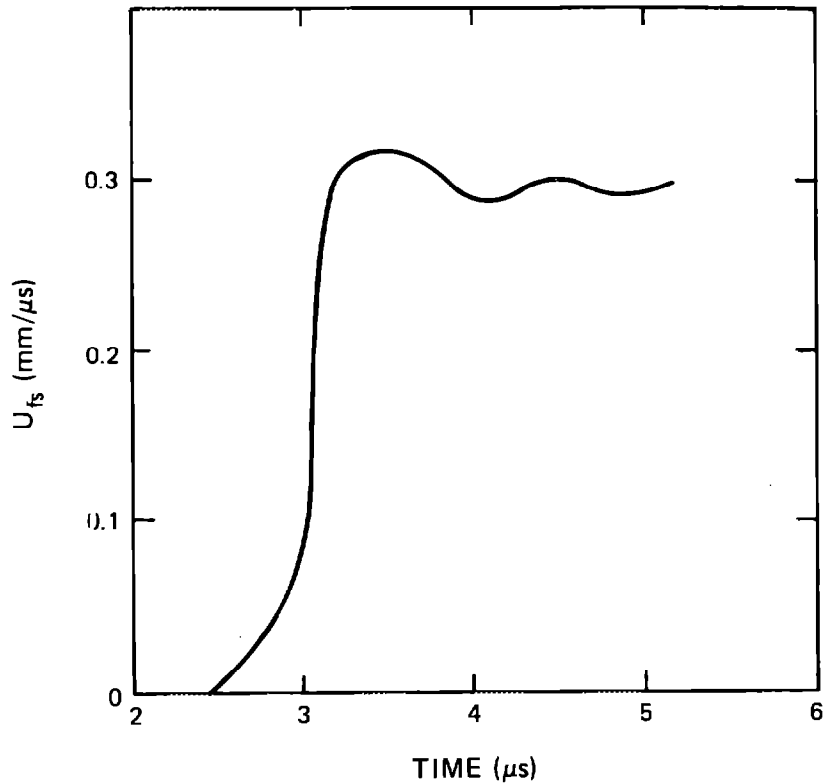
Time: Relative

TARGET

Material: HP-9-4-20 steel
Experiment type: Free-surface capacitor
Experimenters: J. W. Hopson and J. W. Taylor
Shot no.: 56-71-38 **Date:** November 2, 1971
Thickness: 6.19 mm **Diameter:** 38.1 mm
Density: 7.84 g/cm³
C_L = 6.09 mm/μs **C_S** = 3.10 mm/μs

IMPACTOR

Steel disk, backed with low-density polyurethane foam, mounted on 51-mm-diam aluminum alloy projectile

TRANSDUCER

Free-surface capacitor
Time: Relative

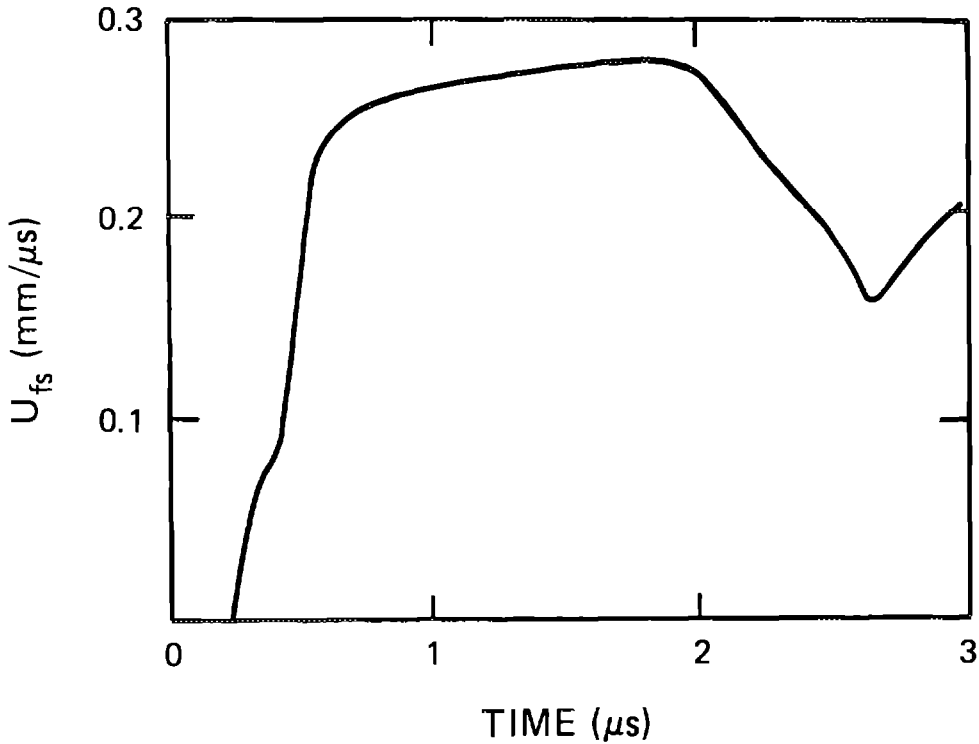

TARGET **Material:** Military specification 12560-B armor plate
Experiment type: Free-surface capacitor
Experimenter: J. W. Hopson
Shot no.: 56-72-32 **Date:** April 21, 1972

IMPACTOR **Armor steel, 4.75 mm thick, backed with low-density poly-
urethane foam, mounted on 51-mm-diam aluminum alloy projectile**
Impact velocity: 0.296 mm/ μ s

TRANSDUCER **Free-surface capacitor**
Time: Relative

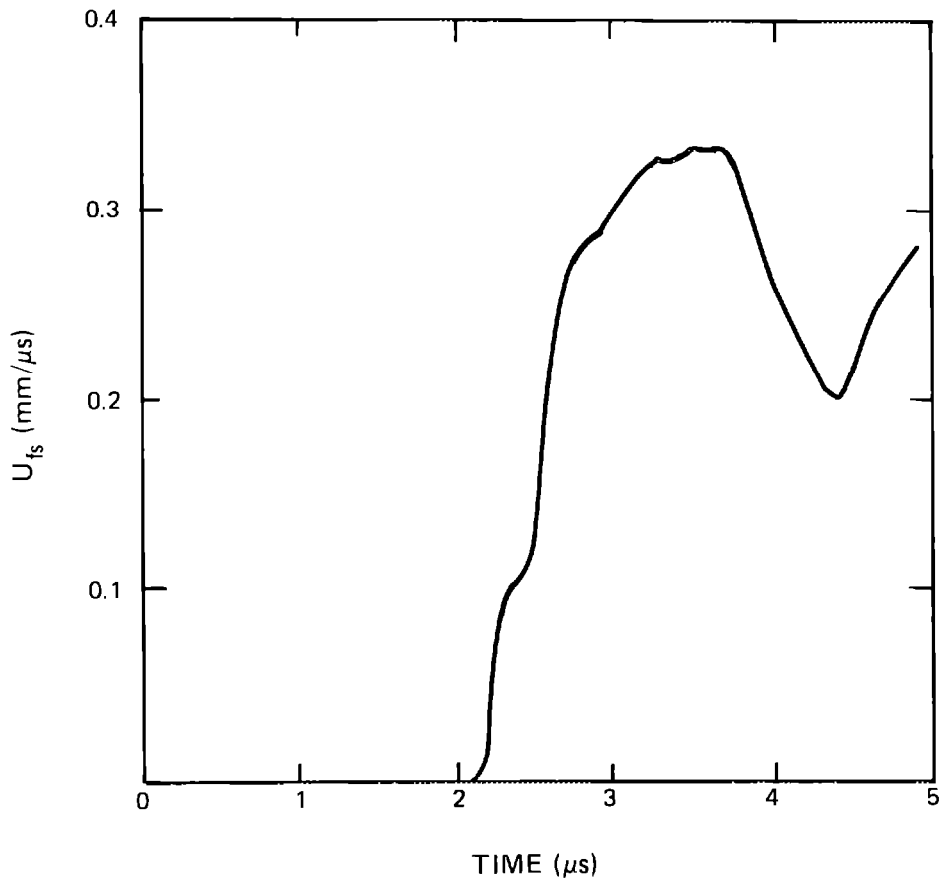

TARGET

Material: HY-80 naval armor steel
Experiment type: Free-surface capacitor
Experimenter: J. W. Hopson
Shot no.: 56-74-9 **Date:** April 1, 1974
Thickness: 12.56 mm **Diameter:** 38.1 mm
Density: 7.84 g/cm³
C_L = 6.28 mm/μs **C_S** = 3.44 mm/μs

IMPACTOR

OFHC copper, 4.76 mm thick, backed with low-density polyurethane foam, mounted on 51-mm-diam aluminum alloy projectile

TRANSDUCER

Free-surface capacitor
Time: Relative

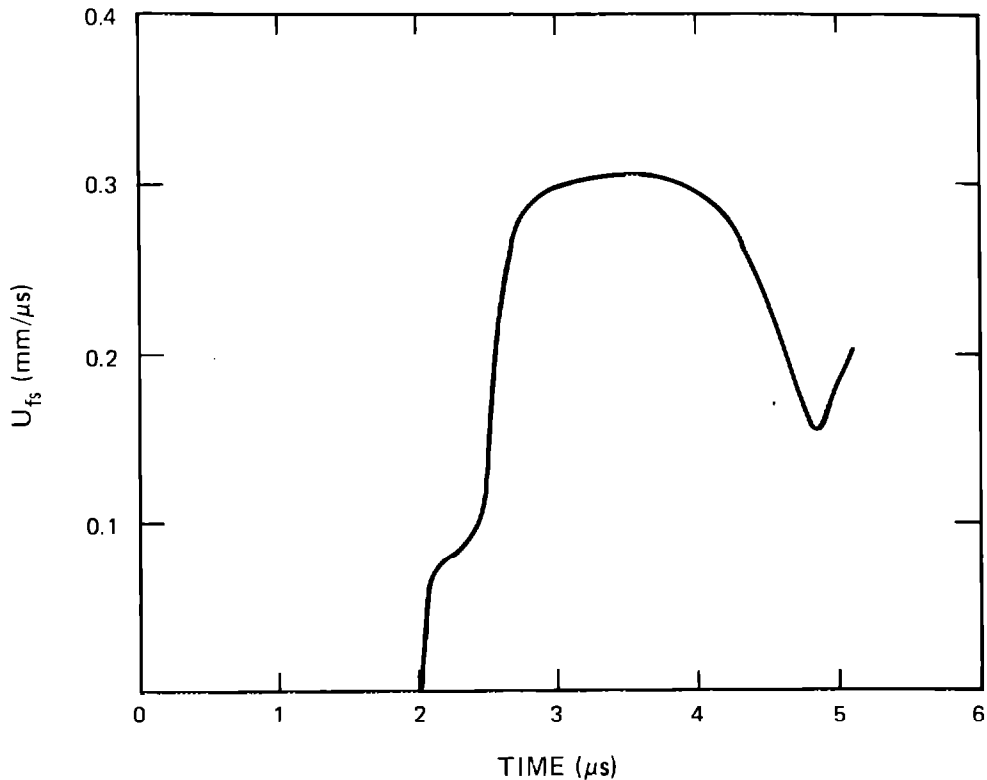

TARGET **Material:** 301 stainless steel at 300 K
Experiment type: Free-surface capacitor
Experimenter: J. W. Taylor
Shot no.: 56-62-136 **Date:** July 12, 1965
Thickness: 12.70 mm **Diameter:** 38.1 mm

IMPACTOR OFHC copper, 6.35 mm thick, backed with low-density poly-
urethane foam, mounted on 51-mm-diam aluminum alloy projectile

TRANSDUCER Free-surface capacitor
Time: Relative

NOTES Shots 56-62-136, 56-64-305, and 56-64-308 are a 301 stainless steel
series with varied ambient temperatures.

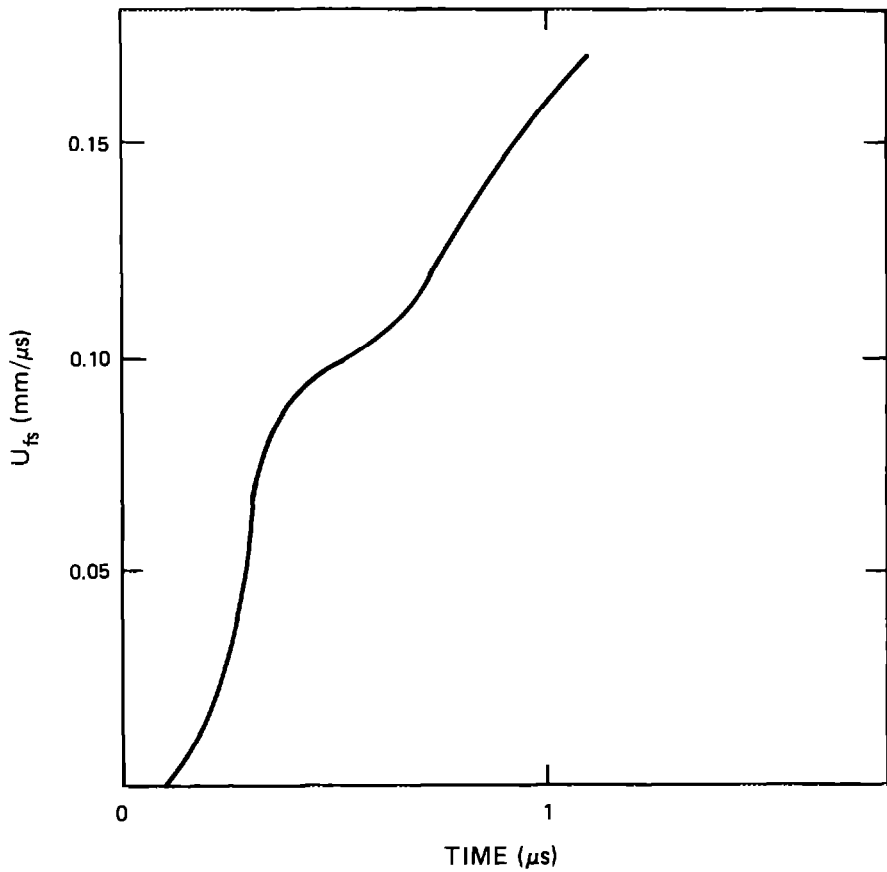

TARGET **Material:** 301 stainless steel at 560 K
Experiment type: Free-surface capacitor
Experimenter: J. W. Taylor
Shot no.: 56-64-305 **Date:** July 14, 1964
Thickness: 12.70 mm **Diameter:** 38.1 mm

IMPACTOR OFHC copper, 6.35 mm thick, backed with low-density poly-
urethane foam, mounted on 51-mm-diam aluminum alloy
projectile

TRANSDUCER Free-surface capacitor
Time: Relative

NOTES Shots 56-62-136, 56-64-305, and 56-64-308 are a 301 stainless steel
series with varied ambient temperatures.

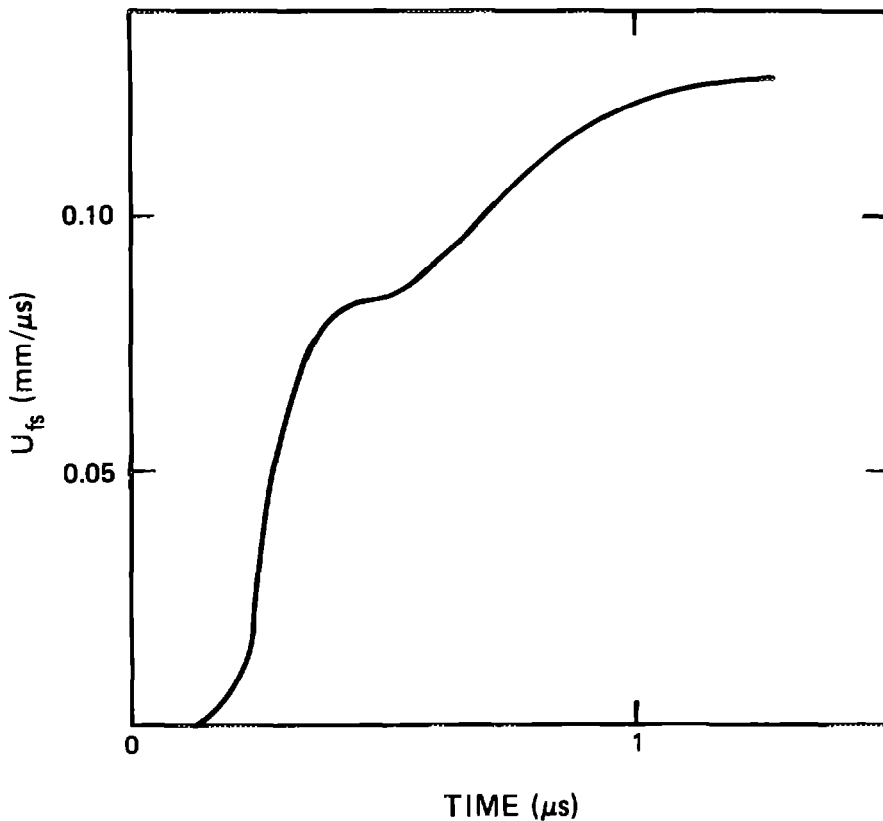

TARGET

Material: 301 stainless steel at 690 K
Experiment type: Free-surface capacitor
Experimenter: J. W. Taylor
Shot no.: 56-64-308 **Date:** July 17, 1964
Thickness: 12.70 mm **Diameter:** 38.1 mm

IMPACTOR

OFHC copper, 6.35 mm thick, backed with low-density polyurethane foam, mounted on 51-mm-diam aluminum alloy projectile

TRANSDUCER

Free-surface capacitor
Time: Relative

NOTES

Shots 56-62-136, 56-64-305, and 56-64-308 are a 301 stainless steel series with varied ambient temperatures.

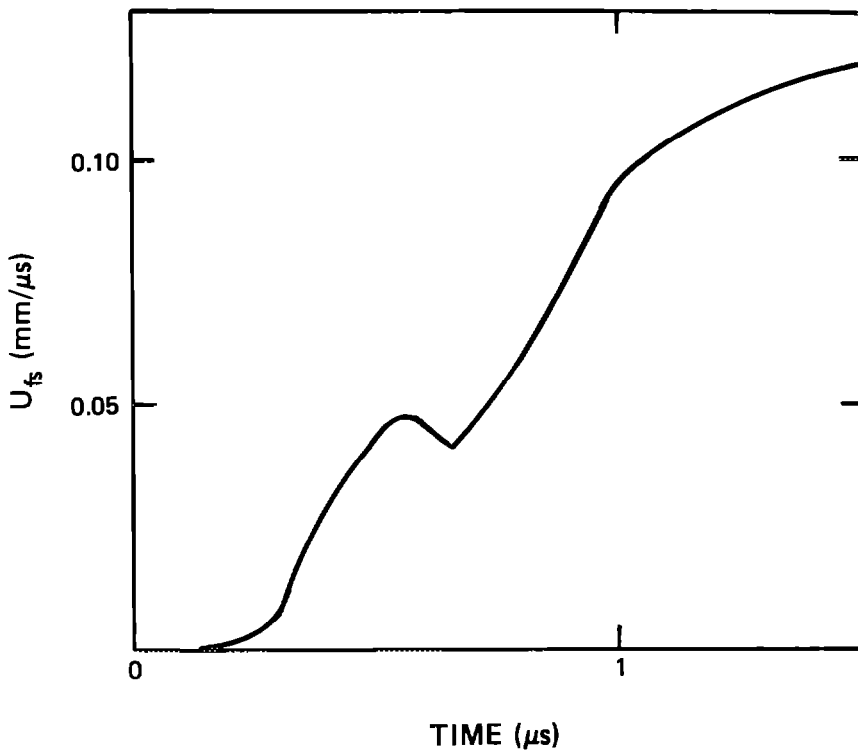

TARGET**Material:** 304 stainless steel**Experiment type:** Free-surface capacitor**Experimenter:** J. W. Taylor**Reference:** R. G. McQueen, S. P. Marsh, J. W. Taylor, J. N. Fritz, and W. J. Carter (1970)**Shot no.:** 56-66-401 **Date:** May 16, 1966**Thickness:** 11.39 mm **Diameter:** 38.1 mm**Density:** 7.89 g/cm³**C_L =** 5.77 mm/μs **C_S =** 3.12 mm/μs**IMPACTOR**

304 stainless steel, 3.18 mm thick, backed with low-density polyurethane foam, mounted on 51-mm-diam aluminum alloy projectile

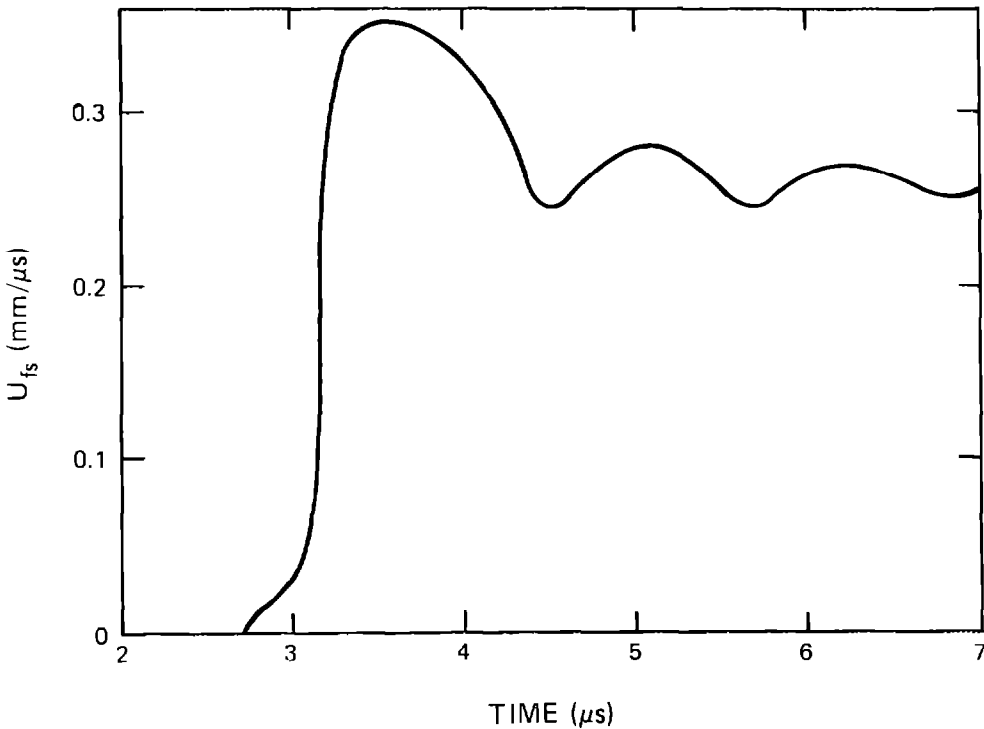
TRANSDUCER Free-surface capacitor**Time:** Relative

TARGET

Material: 21-6-9 stainless steel
Experiment type: Free-surface capacitor
Experimenter: J. W. Hopson
Shot no.: 56-73-10 **Date:** February 20, 1973
Thickness: 6.63 mm **Diameter:** 38.1 mm
Density: 7.81 g/cm³
C_L = 5.72 mm/μs **C_s** = 3.14 mm/μs
Heat treatment: Annealed

IMPACTOR

OFHC copper, 3.18 mm thick, backed with low-density polyurethane foam, mounted on 51-mm-diam aluminum alloy projectile
Impact velocity: 0.284 mm/μs

TRANSDUCER

Free-surface capacitor
Time: Relative

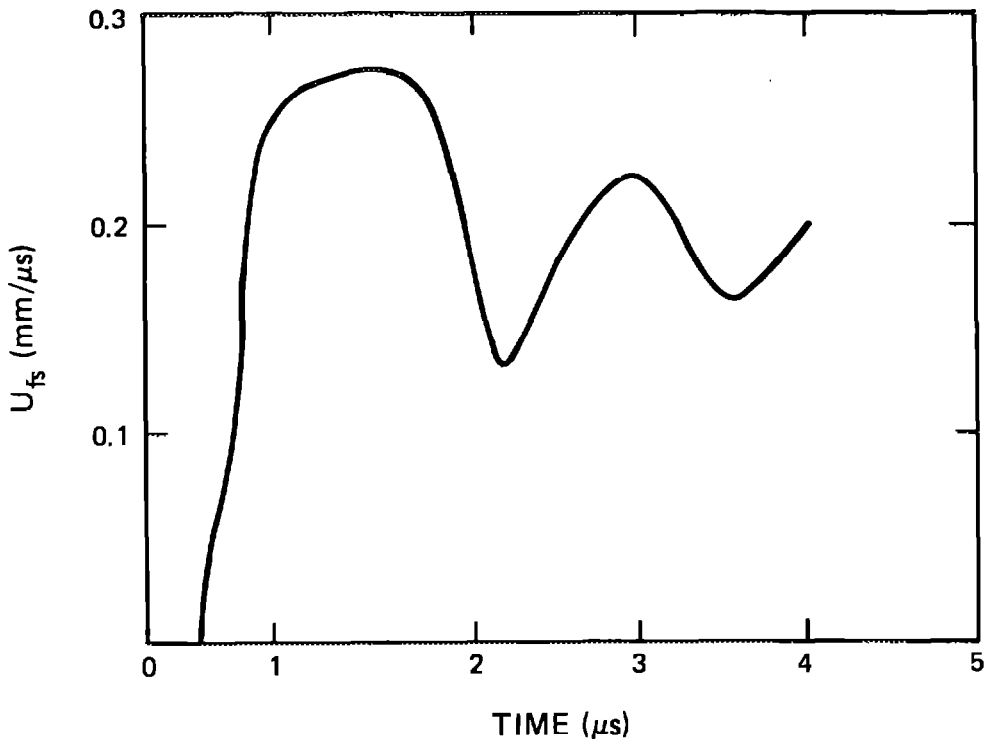

TARGET **Material:** 1018 steel
Experiment type: Free-surface capacitor
Experimenter: J. W. Taylor
Shot no.: 56-63-218 **Date:** April 24, 1963
Thickness: 12.72 mm **Diameter:** 38.1 mm
Density: 7.861 g/cm³
C_L = 5.92 mm/μs **C_s** = 3.19 mm/μs

IMPACTOR Iron, 6.35 mm thick, backed with low-density polyurethane foam,
mounted on 51-mm-diam aluminum alloy projectile
Impact velocity: 0.191 mm/μs

TRANSDUCER Free-surface capacitor
Time: Relative

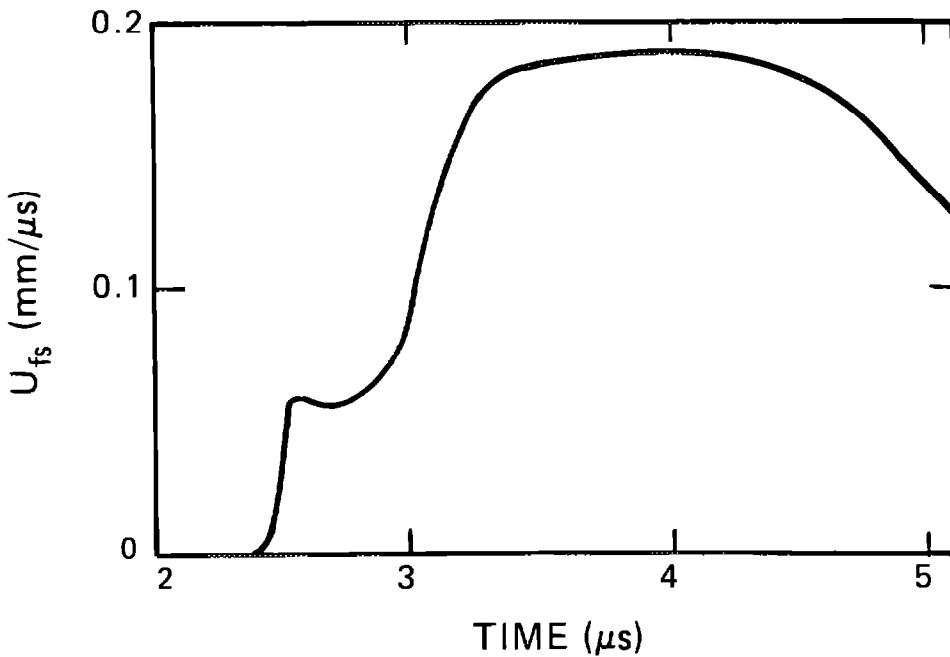

TARGET

Material: 1018 steel at 101°C
Experiment type: Free-surface capacitor
Experimenter: J. W. Taylor
Shot no.: 56-66-368 **Date:** January 5, 1966
Thickness: 12.70 mm **Diameter:** 38.1 mm
Density: 7.861 g/cm³
C_L = 5.92 mm/μs **C_S** = 3.19 mm/μs

IMPACTOR

Steel disk, mounted on 51-mm-diam aluminum alloy projectile

TRANSDUCER

Free-surface capacitor
Time: Relative

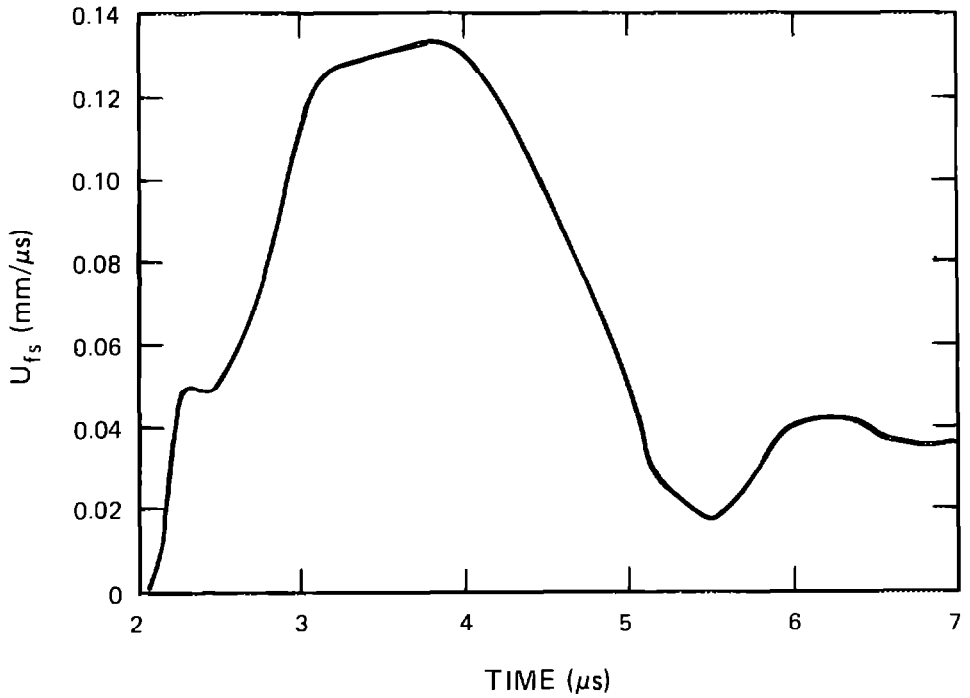

TARGET **Material:** 1045 carbon steel
Experiment type: Free-surface capacitor
Experimenter: J. W. Taylor
Shot no.: 56-63-206 **Date:** April 8, 1963
Thickness: 18.42 mm **Diameter:** 152 mm
Heat treatment: Annealed

IMPACTOR Iron, 6.35 mm thick, backed with low-density polyurethane foam,
mounted on 51-mm-diam aluminum alloy projectile

TRANSDUCER Free-surface capacitor
Time: Relative

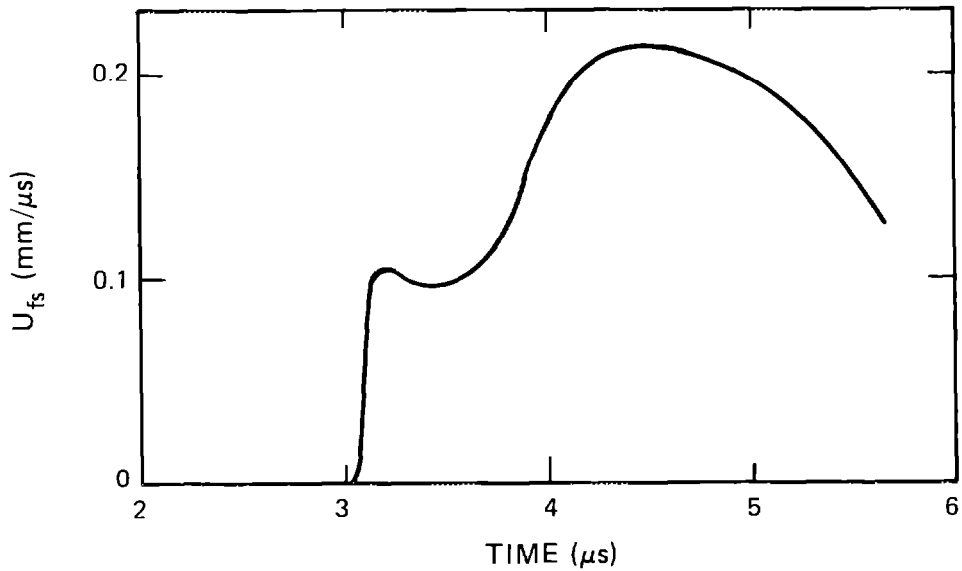

TARGET

Material: 1095 carbon steel
Experiment type: Free-surface capacitor
Experimenter: J. W. Taylor
Shot no.: 56-63-207 **Date:** April 8, 1963
Thickness: 15.57 mm **Diameter:** 38.1 mm
Density: 7.86 g/cm³
C_L = 5.90 mm/μs **C_s = 3.21 mm/μs**

IMPACTOR

Iron, 6.35 mm thick, backed with low-density polyurethane foam, mounted on 51-mm-diam aluminum alloy projectile

TRANSDUCER

Free-surface capacitor
Time: Relative

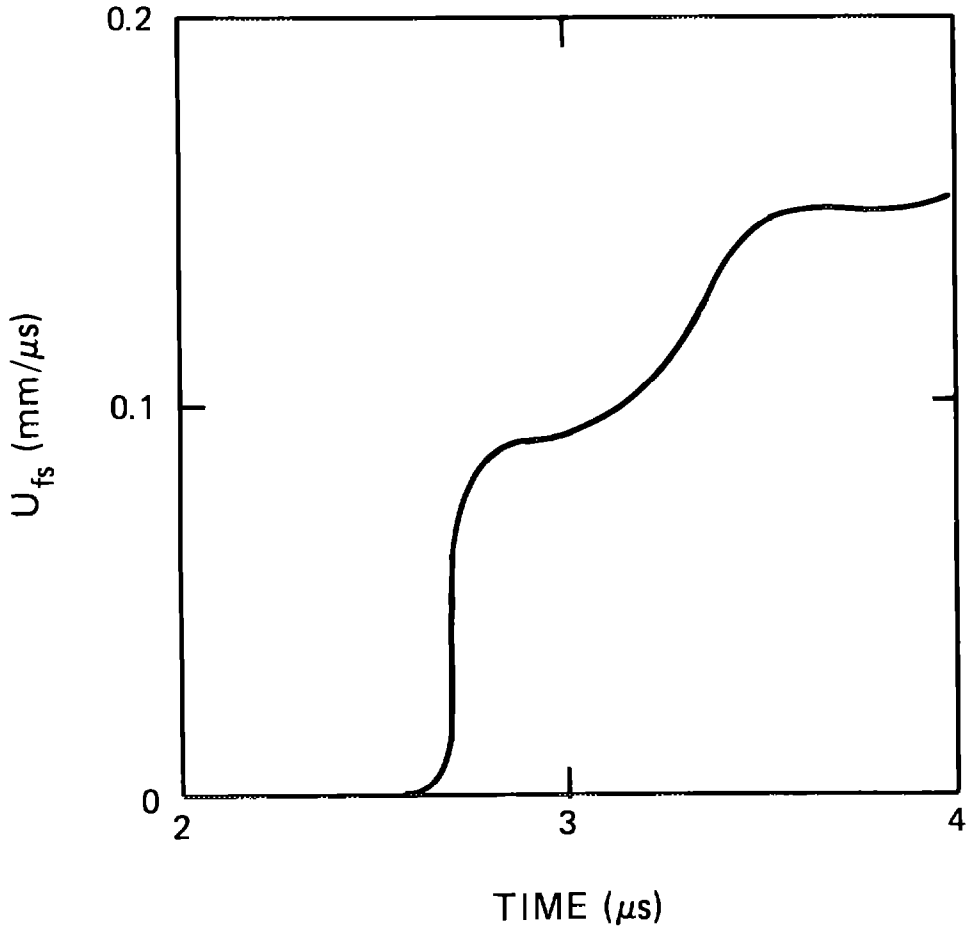

TARGET**Material:** 4150 steel**Experiment type:** Free-surface capacitor**Experimenter:** J. W. Taylor**Reference:** R. G. McQueen, S. P. Marsh, J. W. Taylor, J. N. Fritz, and W. J. Carter (1970)**Shot no.:** 56-67-448 **Date:** October 13, 1967**Thickness:** 12.7 mm **Diameter:** 38.1 mm**Density:** 7.785 g/cm³**C_L =** 5.89 mm/μs **C_S =** 3.20 mm/μs**Hardness:** Rc 62**IMPACTOR**

1018 steel, 6.35 mm thick, backed with low-density polyurethane foam, mounted on 51-mm-diam aluminum alloy projectile

Impact velocity: 0.340 mm/μs**TRANSDUCER**

Free-surface capacitor

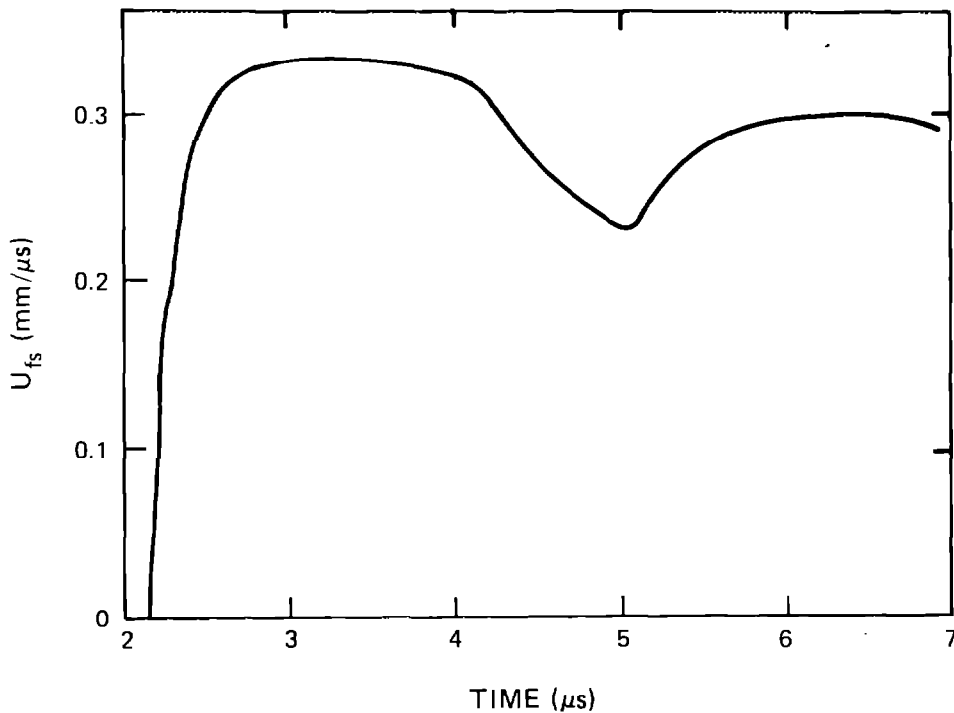
Time: Relative

TARGET

Material: Vascomax 250 steel
Experiment type: Free-surface capacitor
Experimenters: J. W. Hopson and J. W. Taylor
Shot no.: 56-71-35 **Date:** October 27, 1971
Thickness: 13.23 mm **Diameter:** 38.1 mm
Density: 8.0 g/cm³
 $C_L = 5.54$ mm/ μ s $C_s = 2.96$ mm/ μ s

IMPACTOR

Steel disk, backed with low-density polyurethane foam, mounted on 51-mm-diam aluminum alloy projectile
Impact velocity: 0.321 mm/ μ s

TRANSDUCER

Free-surface capacitor
Time: Relative

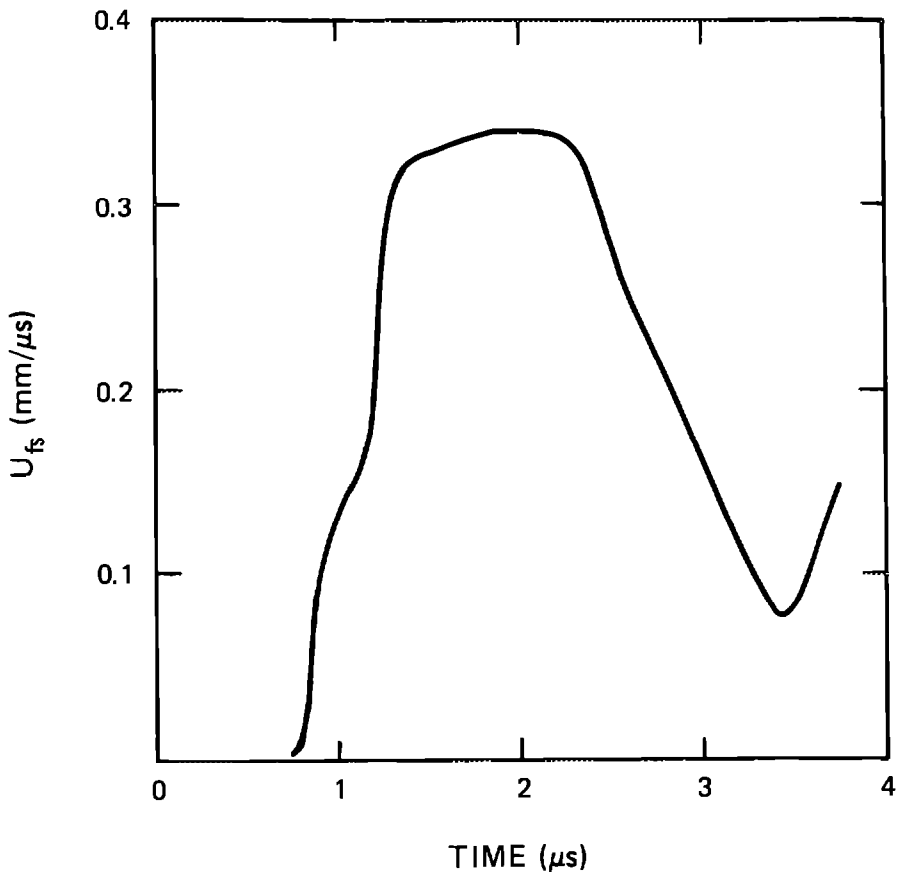

TARGET

Material: Sintered Vascomax 250 steel
Experiment type: Free-surface capacitor
Experimenter: J. W. Hopson
Shot no.: 56-73-13 **Date:** February 21, 1973
Thickness: 7.14 mm **Diameter:** 38.1 mm
Density: 6.17 g/cm³
 $C_L = 4.17$ mm/ μ s $C_s = 2.30$ mm/ μ s

IMPACTOR

Steel disk, 6.12 mm thick, backed with low-density polyurethane foam, mounted on 51-mm-diam aluminum alloy projectile

TRANSDUCER

Free-surface capacitor
Time: Relative

NOTES

The wave profile of the sintered Vascomax 250 sample was recorded after traveling through 7.52 mm of OFHC copper.

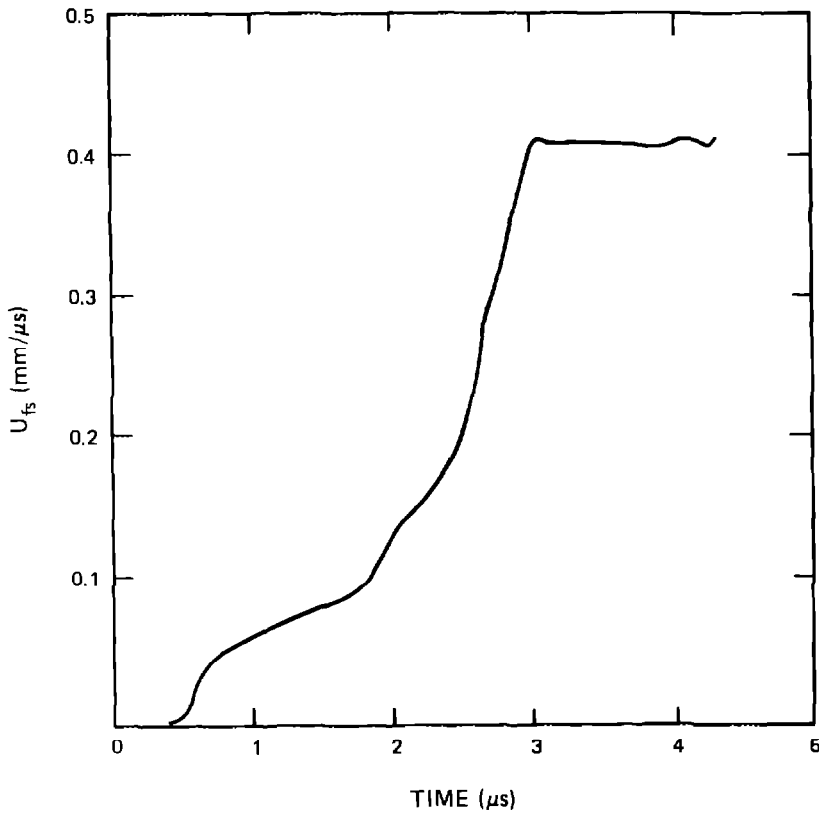

TARGET

Material: Vascomax 300 steel
Experiment type: Free-surface capacitor
Experimenters: J. W. Hopson and J. W. Taylor
Shot no.: 56-71-33 **Date:** October 18, 1971
Thickness: 9.35 mm **Diameter:** 38.1 mm
Density: 8.0 g/cm³
 $C_L = 5.54 \text{ mm}/\mu\text{s}$ $C_S = 2.96 \text{ mm}/\mu\text{s}$

IMPACTOR

Steel disk, backed with low-density polyurethane foam, mounted on 51-mm-diam aluminum alloy projectile
Impact velocity: 0.285 mm/ μs

TRANSDUCER

Free-surface capacitor
Time: Relative

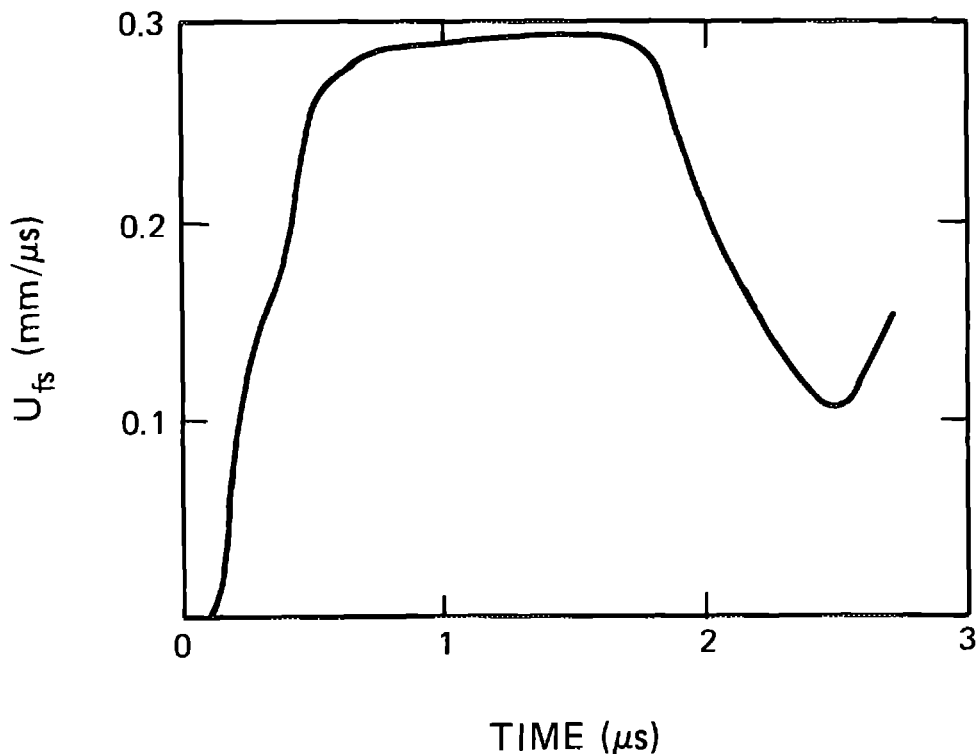

TARGET

Material: 90 wt% tantalum with 10 wt% tungsten
Experiment type: Free-surface capacitor
Experimenter: J. W. Hopson
Shot no.: 56-73-7 **Date:** February 14, 1973
Thickness: 6.09 mm **Diameter:** 38.1 mm
Density: 16.93 g/cm³
C_L = 4.20 mm/μs **C_s** = 2.12 mm/μs
Heat treatment: Annealed at 1450°C for 2 hours

IMPACTOR

OFHC copper, 2.97 mm thick, backed with low-density polyurethane foam, mounted on 51-mm-diam aluminum alloy projectile
Impact velocity: 0.261 mm/μs

TRANSDUCER

Free-surface capacitor
Time: Relative

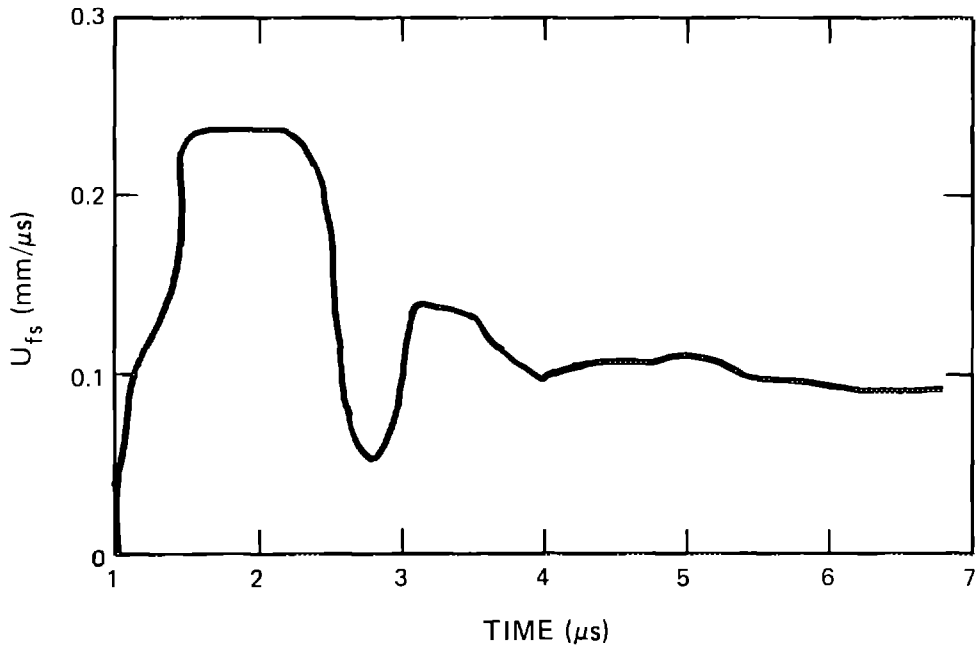

TARGET

Material: 98.5 wt% tungsten with 0.5 wt% nickel and 1 wt% iron alloy

Experiment type: Free-surface capacitor

Experimenter: J. W. Hopson

Shot no.: 56-73-71 **Date:** December 12, 1973

Thickness: 12.71 mm **Diameter:** 41.3 mm

Density: 18.69 g/cm³

$C_L = 5.14$ mm/ μ s $C_g = 2.85$ mm/ μ s

Heat treatment: Sintered at 1460°C

IMPACTOR

OFHC copper, 4.95 mm thick, backed with low-density polyurethane foam, mounted on 51-mm-diam aluminum alloy projectile

TRANSDUCER

Free-surface capacitor

Time: Relative

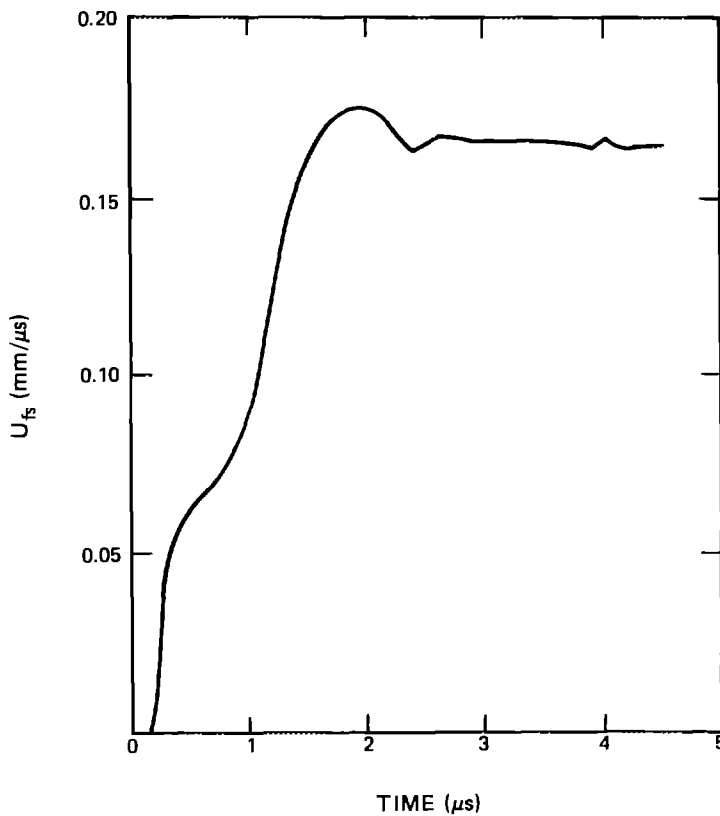

TARGET

Material: 95 wt% tungsten with 2.1 wt% nickel, 1.4 wt% iron, and 1.5 wt% cobalt alloy

Experiment type: Free-surface capacitor

Experimenter: J. W. Hopson

Shot no.: 56-73-72 **Date:** December 13, 1973

Thickness: 12.72 mm **Diameter:** 41.4 mm

Density: 17.94 g/cm³

$C_L = 5.17 \text{ mm}/\mu\text{s}$ $C_g = 2.85 \text{ mm}/\mu\text{s}$

Heat treatment: Sintered at 1460°C

IMPACTOR

OFHC copper, 4.95 mm thick, backed with low-density polyurethane foam, mounted on 51-mm-diam aluminum alloy projectile

TRANSDUCER

Free-surface capacitor

Time: Relative

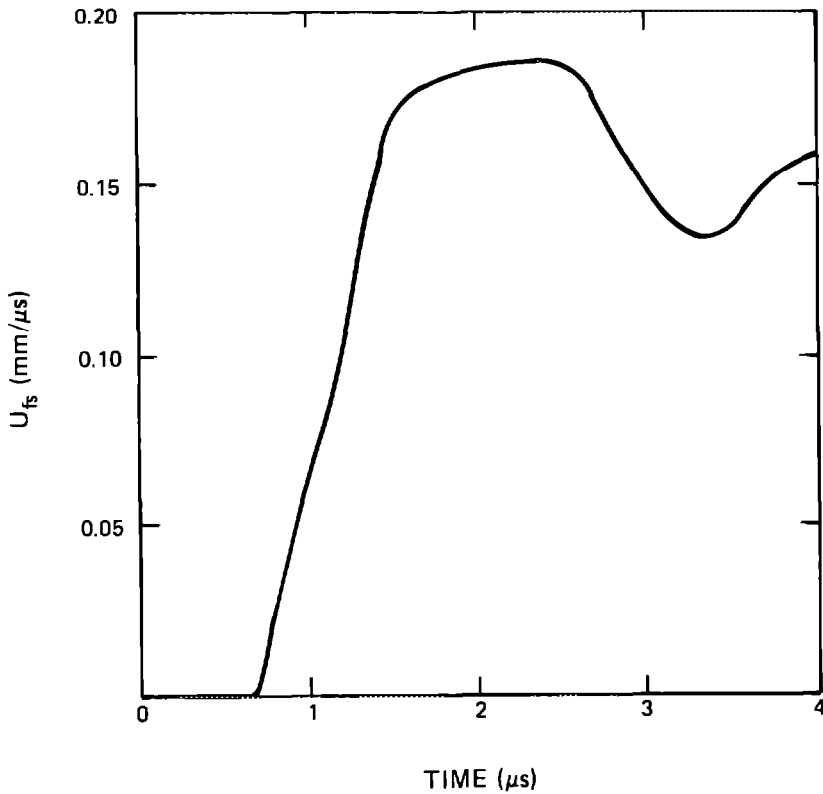

TARGET

Material: 95 wt% tungsten with 3.5 wt% nickel and 1.5 wt% iron alloy

Experiment type: Free-surface capacitor

Experimenter: J. W. Hopson

Shot no.: 56-73-5 **Date:** February 12, 1973

Thickness: 12.87 mm **Diameter:** 41.4 mm

Density: 18.06 g/cm³

$C_L = 5.19$ mm/ μ s $C_S = 2.85$ mm/ μ s

IMPACTOR

OFHC copper, 4.93 mm thick, backed with low-density polyurethane foam, mounted on 51-mm-diam aluminum alloy projectile

Impact velocity: 0.288 mm/ μ s

TRANSDUCER

Free-surface capacitor

Time: Relative

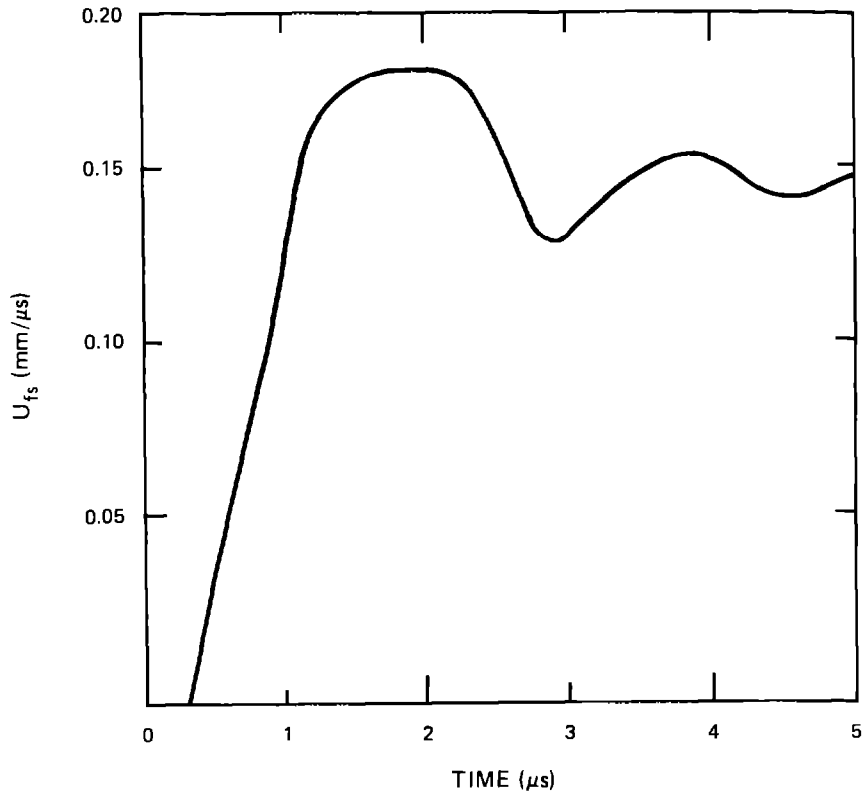

TARGET **Material:** 75 wt% tungsten with 25 wt% rhenium alloy
Experiment type: Free-surface capacitor
Experimenter: J. W. Hopson
Shot no.: 56-73-6 **Date:** February 13, 1973
Thickness: 11.24 mm **Diameter:** 41.3 mm
Density: 19.66 g/cm³
C_L = 5.18 mm/μs **C_S** = 2.91 mm/μs

IMPACTOR OFHC copper, 4.93 mm thick, backed with low-density poly-
foam, mounted on 51-mm-diam aluminum alloy projectile
Impact velocity: 0.297 mm/μs

TRANSDUCER Free-surface capacitor
Time: Relative

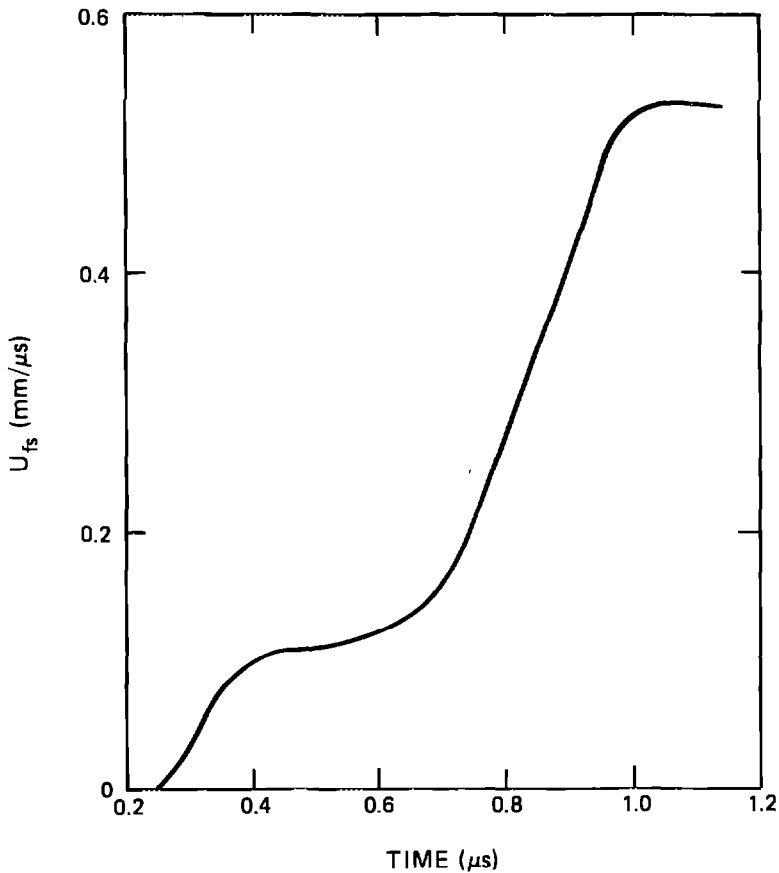

TARGET

Material: 91 wt% tungsten with 5 wt% rhenium, 1.4 wt% platinum, 1.4 wt% nickel, and 1.2 wt% iron alloy
Experiment type: Free-surface capacitor
Experimenter: J. W. Hopson
Shot no.: 56-72-43 **Date:** May 19, 1972
Thickness: 12.83 mm **Diameter:** 41.3 mm
Density: 18.85 g/cm³
 $C_L = 5.13 \text{ mm}/\mu\text{s}$ $C_S = 2.77 \text{ mm}/\mu\text{s}$

IMPACTOR

OFHC copper, 4.95 mm thick, backed with low-density polyurethane foam, mounted on 51-mm-diam aluminum alloy projectile
Impact velocity: 0.294 mm/ μs

TRANSDUCER

Free-surface capacitor
Time: Relative

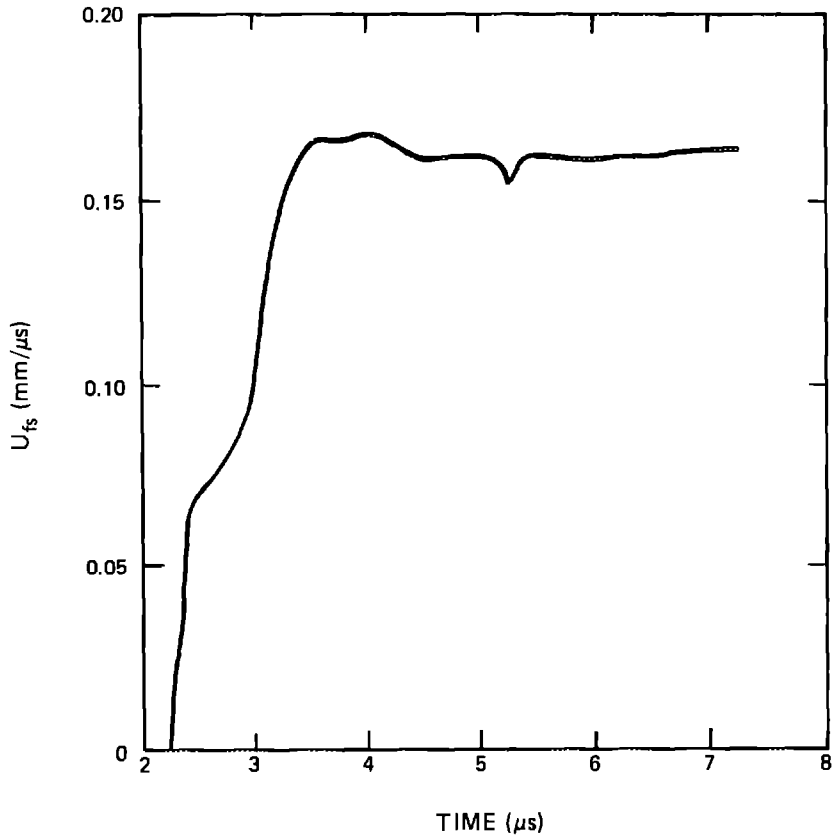

TARGET

Material: 91 wt% tungsten with 5 wt% rhenium, 1.4 wt% platinum, 1.4 wt% nickel, and 1.2 wt% iron alloy
Experiment type: Free-surface capacitor
Experimenter: J. W. Hopson
Shot no.: 56-73-1 **Date:** February 2, 1973
Thickness: 12.85 mm **Diameter:** 41.3 mm
Density: 18.84 g/cm³
C_L = 5.13 mm/μs **C_S** = 2.77 mm/μs

IMPACTOR

OFHC copper, 4.93 mm thick, backed with low-density polyurethane foam, mounted on 51-mm-diam aluminum alloy projectile

TRANSDUCER

Free-surface capacitor
Time: Relative

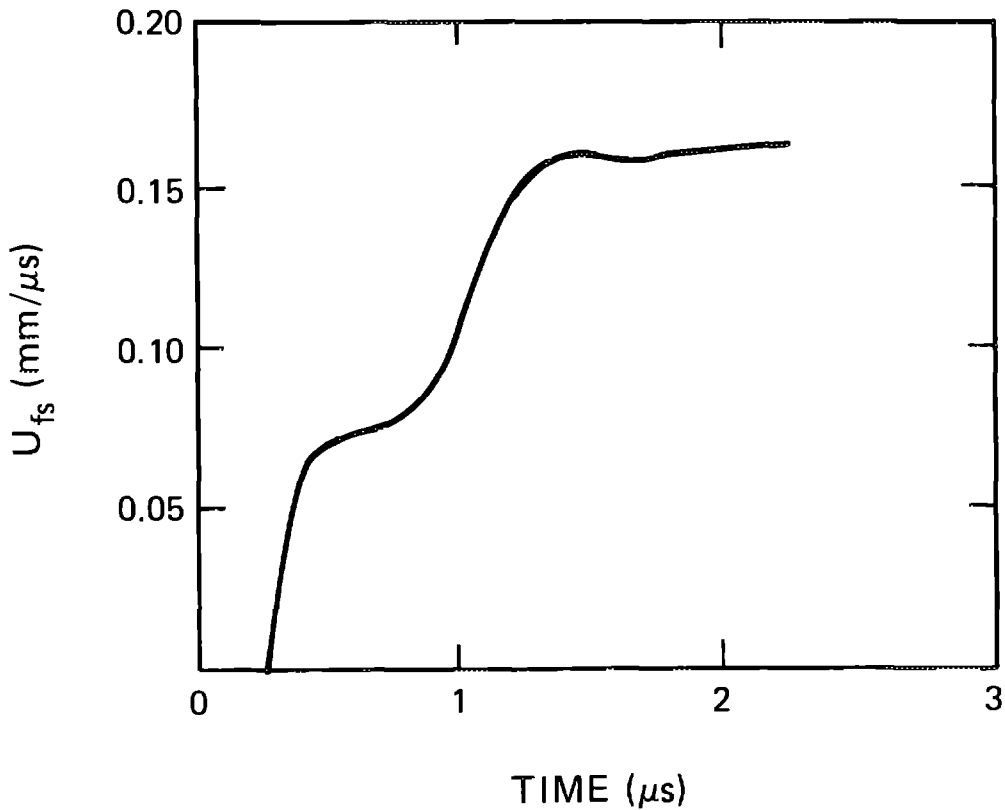

TARGET

Material: 99.5 wt% uranium with 0.5 wt% molybdenum
Experiment type: Free-surface capacitor
Experimenter: J. W. Hopson
Shot no.: 56-71-41 **Date:** November 4, 1971
Thickness: 12.7 mm **Diameter:** 38.1 mm
Density: 18.6 g/cm³
C_L = 3.3 mm/μs **C_S** = 1.8 mm/μs
Heat treatment: Gamma-quenched in water

IMPACTOR

OFHC copper, 5.82 mm thick, backed with low-density poly-urethane foam, mounted on 51-mm-diam aluminum alloy projectile
Impact velocity: 0.300 mm/μs

TRANSDUCER

Free-surface capacitor
Time: Relative

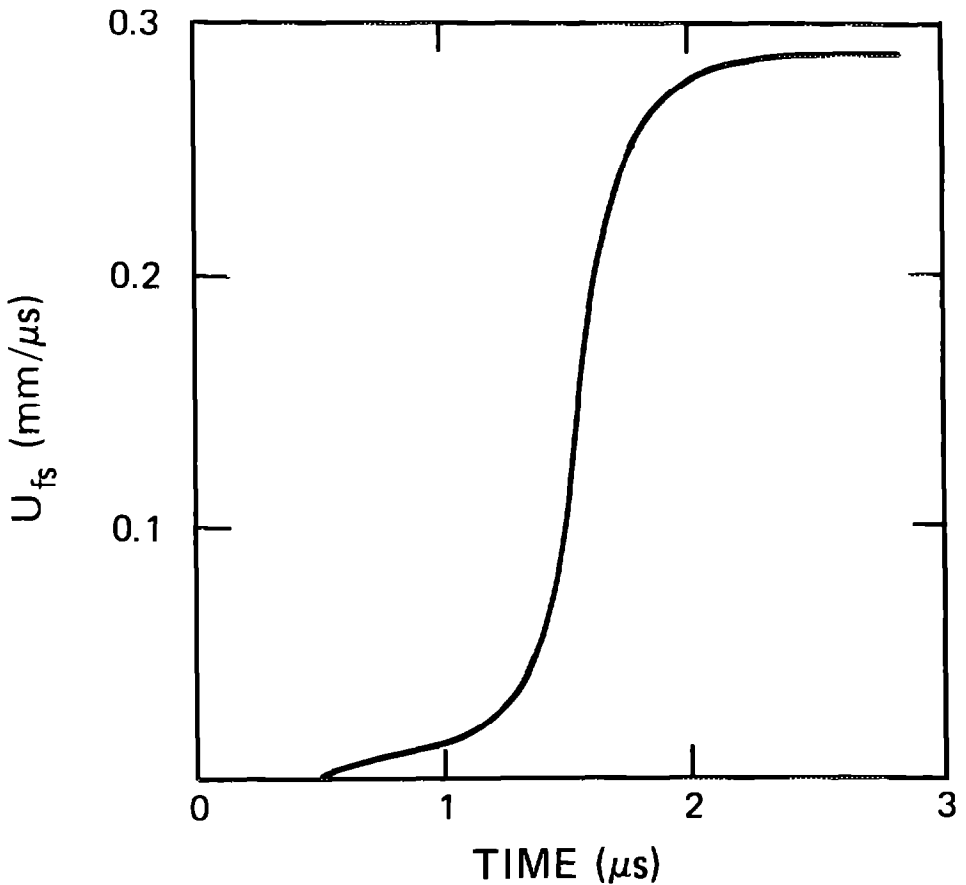

TARGET

Material: 98 wt% uranium with 2 wt% molybdenum

Experiment type: Free-surface capacitor

Experimenter: J. W. Hopson

Shot no.: 56-72-4 **Date:** January 6, 1972

Thickness: 9.63 mm **Diameter:** 38.1 mm

Density: 18.6 g/cm³

$C_L = 3.26$ mm/ μ s $C_S = 1.84$ mm/ μ s

Heat treatment: Gamma-quenched from 850°C, aged at 300°C

Hardness: Rc 45.8

IMPACTOR

OFHC copper, 5.0 mm thick, backed with low-density polyurethane foam, mounted on 51-mm-diam aluminum alloy projectile

Impact velocity: 0.264 mm/ μ s

TRANSDUCER Free-surface capacitor

Time: Relative

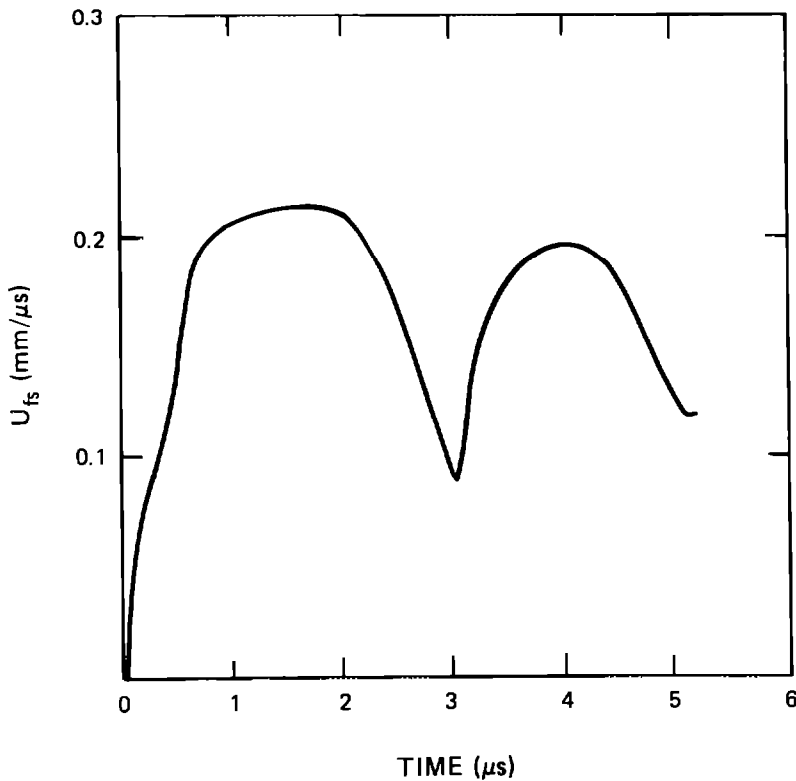

TARGET

Material: 97.96 wt% uranium with 2.04 wt% molybdenum

Experiment type: Free-surface capacitor

Experimenter: J. W. Hopson

Shot no.: 56-72-36 **Date:** April 26, 1972

Thickness: 12.75 mm **Diameter:** 49.3 mm

Density: 18.6 g/cm³

$C_L = 3.26$ mm/ μ s $C_S = 1.84$ mm/ μ s

Heat treatment: Gamma-quenched from 850°C in H₂O, aged at 450°C

Hardness: Rc 46.0

IMPACTOR

OFHC copper, 5.0 mm thick, backed with low-density polyurethane foam, mounted on 51-mm-diam aluminum alloy projectile

Impact velocity: 0.259 mm/ μ s

TRANSDUCER

Free-surface capacitor

Time: Relative

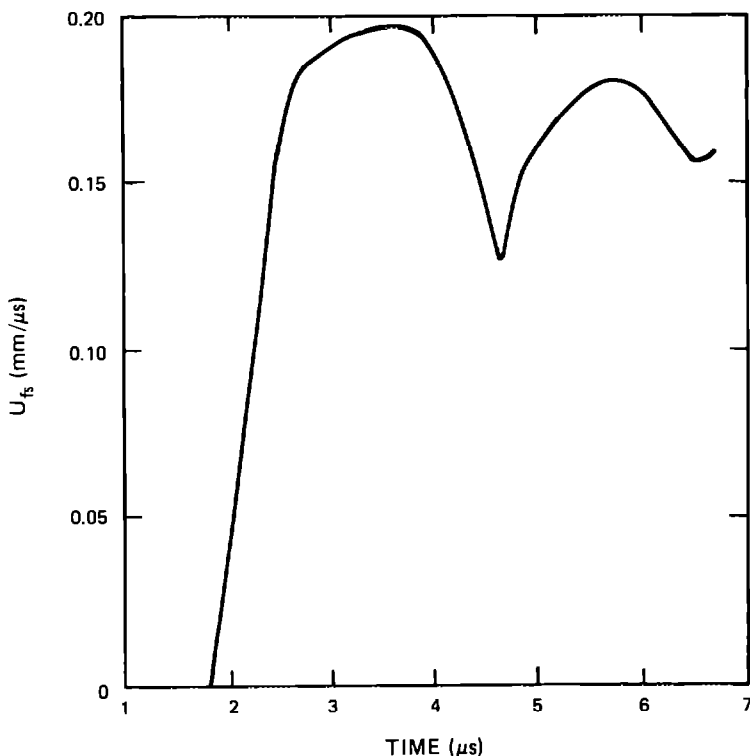

TARGET

Material: 94 wt% uranium with 6 wt% niobium
Experiment type: Free-surface capacitor
Experimenter: J. W. Hopson
Shot no.: 56-75-20 **Date:** June 27, 1975
Thickness: 12.6 mm **Diameter:** 41.3 mm
Density: 17.47 g/cm³
 $C_L = 2.96 \text{ mm}/\mu\text{s}$ $C_s = 1.28 \text{ mm}/\mu\text{s}$

IMPACTOR

OFHC copper, 4.24 mm thick, backed with low-density polyurethane foam, mounted on 51-mm-diam aluminum alloy projectile

TRANSDUCER

Free-surface capacitor
Time: Relative

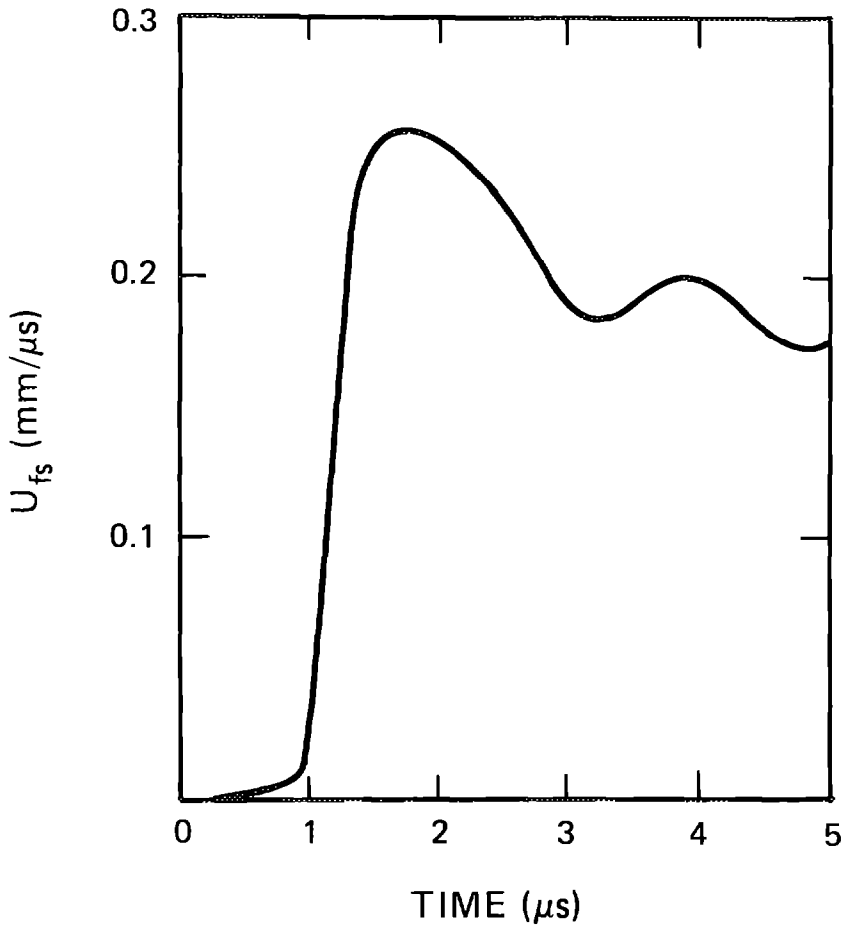

TARGET **Material:** 94 wt% uranium with 6 wt% niobium
Experiment type: Embedded Manganin gage
Experimenter: C. E. Morris
Shot no.: 56-79-4 **Date:** January 17, 1979
Thickness: 16.625 mm **Diameter:** 39.7 mm
Density: 17.390 g/cm³
C_L = 2.90 mm/μs **C_S** = 1.23 mm/μs

IMPACTOR 94 wt% uranium/6 wt% niobium, 2.997 mm thick, backed with low-density polyurethane foam, mounted on 51-mm-diam aluminum alloy projectile
Impact velocity: 0.528 mm/μs

TRANSDUCER Two-terminal, 50-Ω Manganin gage
Location from impact surface: 10.808 mm
Heat treatment: Annealed
Encapsulation: 0.39 mm Al₂O₃ [$\bar{1}\bar{1}02$] on both sides
Calibration: J. W. Hopson and J. W. Taylor calibration formula for Manganin gages
 $\sigma = a_1 x + b_1 x^2 + c_1 x^3$ for $x < 0.1$,
 $\sigma = a_2 + b_2 x + c_2 x^2$ for $x > 0.1$,
where $x = \Delta R/R$.
a₁ = 521.32 **b₁** = -1614.86 **c₁** = 7648.72
a₂ = 6.5950 **b₂** = 370.37 **c₂** = 0.00
Time: Relative

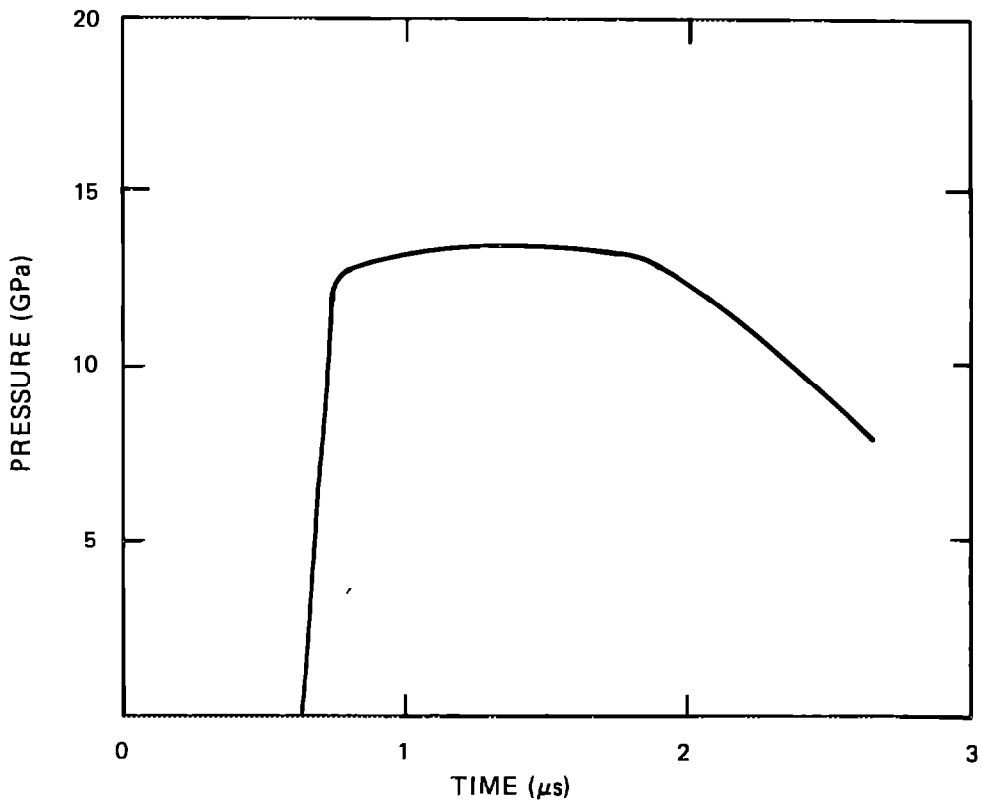

TARGET **Material:** 94 wt% uranium with 6 wt% niobium
Experiment type: Embedded Manganin gage
Experimenter: C. E. Morris
Shot no.: 56-79-8 **Date:** February 9, 1979
Thickness: 15.110 mm **Diameter:** 39.7 mm
Density: 17.390 g/cm³
C_L = 2.90 mm/μs **C_S** = 1.23 mm/μs

IMPACTOR 94 wt% uranium/6 wt% niobium, 3.061 mm thick, backed with low-density polyurethane foam, mounted on 51-mm-diam aluminum alloy projectile
Impact velocity: 0.540 mm/μs

TRANSDUCER Two-terminal, 50-Ω Manganin gage
Location from impact surface: 9.619 mm
Heat treatment: Annealed
Encapsulation: 0.12 mm Al₂O₃ [1 $\bar{1}$ 02] on both sides
Calibration: J. W. Hopson and J. W. Taylor calibration formula for Manganin gages
 $\sigma = a_1 x + b_1 x^2 + c_1 x^3$ for $x < 0.1$,
 $\sigma = a_2 + b_2 x + c_2 x^2$ for $x > 0.1$,
where $x = \Delta R/R$.
a₁ = 521.32 **b₁** = -1614.86 **c₁** = 7648.72
a₂ = 6.5950 **b₂** = 370.37 **c₂** = 0.00
Time: Relative

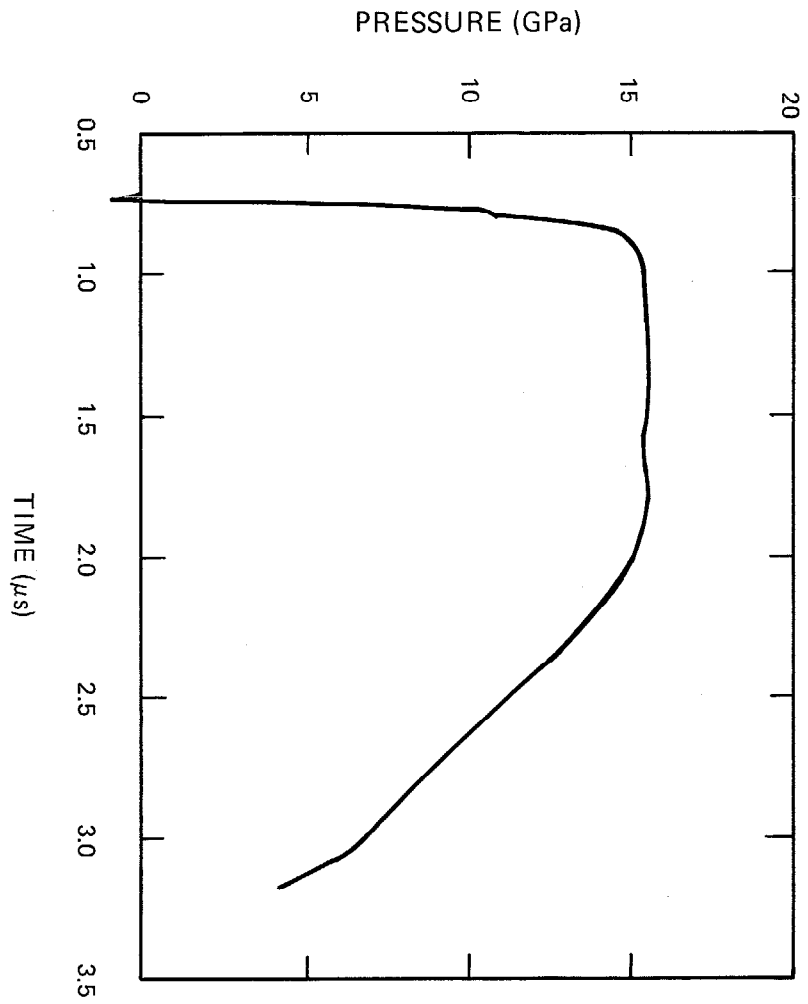

TARGET

Material: 97.03 wt% uranium with 1.16 wt% niobium and 1.81 wt% titanium

Experiment type: Free-surface capacitor

Experimenter: J. W. Hopson

Shot no.: 56-72-10 Date: January 12, 1972

Thickness: 9.72 mm Diameter: 38.1 mm

Density: 17.9 g/cm³

$C_L = 3.45$ mm/ μ s $C_S = 2.08$ mm/ μ s

Heat treatment: Gamma-quenched from 850°C in water, aged at 450°C

Hardness: Rc 53.9

IMPACTOR

OFHC copper, 5.0 mm thick, backed with low-density polyurethane foam, mounted on 51-mm-diam aluminum alloy projectile

Impact velocity: 0.266 mm/ μ s

TRANSDUCER

Free-surface capacitor

Time: Relative

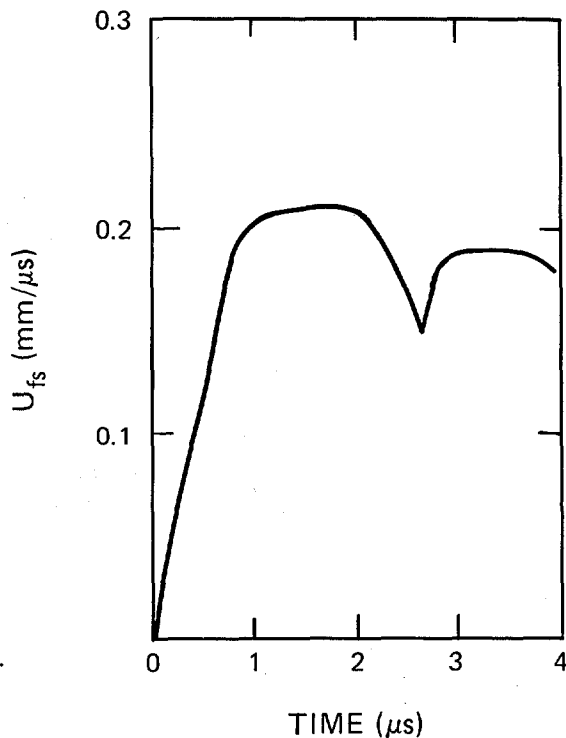

TARGET

Material: 96.19 wt% uranium with 2.53 wt% niobium and 1.28 wt% titanium

Experiment type: Free-surface capacitor

Experimenter: J. W. Hopson

Shot no.: 56-72-40 **Date:** April 28, 1972

Thickness: 9.53 mm **Diameter:** 38.1 mm

Density: 18.0 g/cm³

$C_L = 3.51$ mm/ μ s $C_s = 2.12$ mm/ μ s

Heat treatment: Gamma-quenched from 850°C, aged at 550°C

Hardness: Rc 48.9

IMPACTOR

OFHC copper, 5.0 mm thick, backed with low-density polyurethane foam, mounted on 51-mm-diam aluminum alloy projectile

Impact velocity: 0.260 mm/ μ s

TRANSDUCER

Free-surface capacitor

Time: Relative

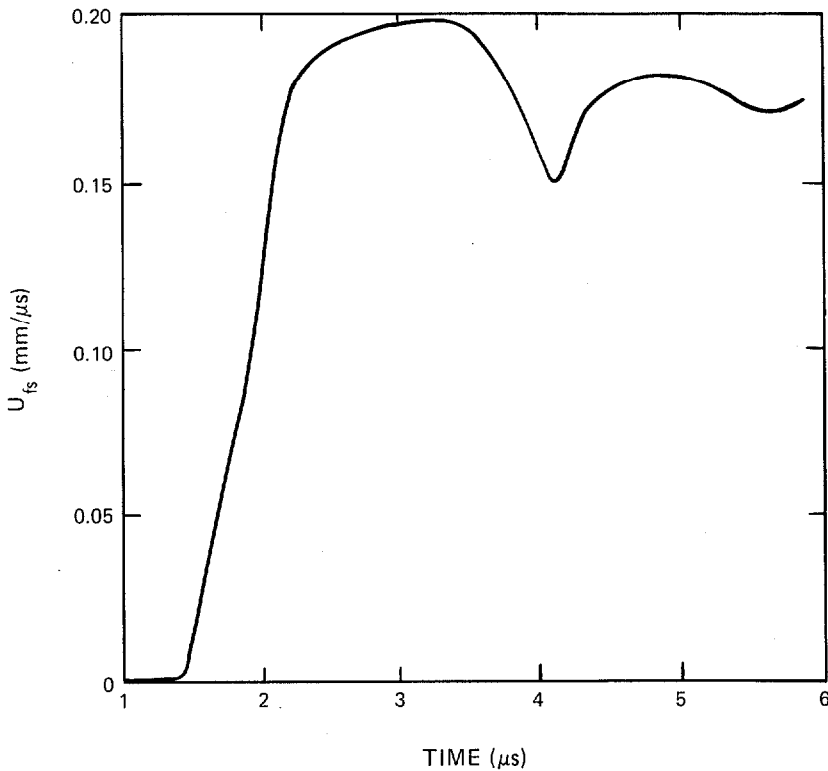

TARGET

Material: 99.38 wt% uranium with 0.62 wt% titanium

Experiment type: Free-surface capacitor

Experimenter: J. W. Hopson

Shot no.: 56-71-51 **Date:** December 9, 1971

Thickness: 9.72 mm **Diameter:** 38.1 mm

Density: 18.6 g/cm³

$C_L = 3.42$ mm/ μ s $C_S = 2.07$ mm/ μ s

Heat treatment: Gamma-quenched from 850°C, aged at 500°C

Hardness: Rc 50.0

IMPACTOR

OFHC copper, 4.97 mm thick, backed with low-density polyurethane foam, mounted on 51-mm-diam aluminum alloy projectile

Impact velocity: 0.262 mm/ μ s

TRANSDUCER

Free-surface capacitor

Time: Relative

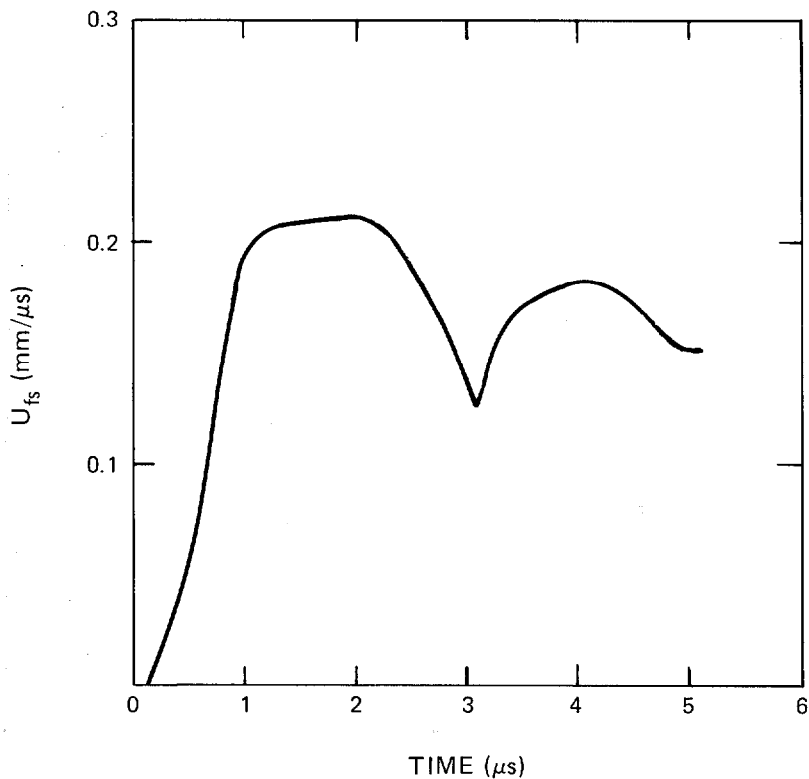

TARGET

Material: 99.23 wt% uranium with 0.77 wt% titanium
Experiment type: Free-surface capacitor
Experimenter: J. W. Hopson
Shot no.: 56-72-7 **Date:** January 11, 1972
Thickness: 9.08 mm **Diameter:** 38.1 mm
Density: 18.5 g/cm³
 $C_L = 3.44$ mm/ μ s $C_S = 2.10$ mm/ μ s
Heat treatment: Gamma-quenched from 850°C to 500°C, aged at 500°C
Hardness: Rc 49.1

IMPACTOR

OFHC copper, 5.0 mm thick, backed with low-density polyurethane foam, mounted on 51-mm-diam aluminum alloy projectile
Impact velocity: 0.276 mm/ μ s

TRANSDUCER

Free-surface capacitor
Time: Relative

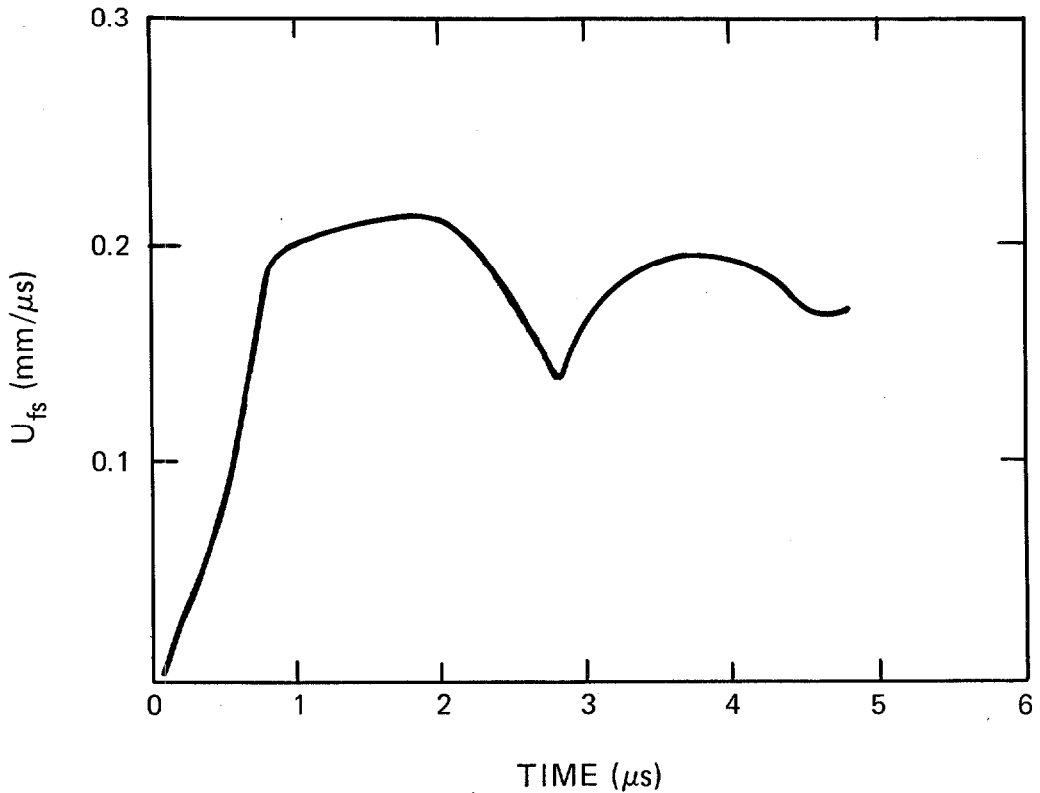

TARGET

Material: 99.16 wt% uranium with 0.84 wt% titanium

Experiment type: Free-surface capacitor

Experimenter: J. W. Hopson

Shot no.: 56-72-33 **Date:** April 21, 1972

Thickness: 3.44 mm **Diameter:** 2.10 mm

Density: 18.5 g/cm³

$C_L = 3.44 \text{ mm}/\mu\text{s}$ $C_S = 2.10 \text{ mm}/\mu\text{s}$

Heat treatment: Gamma-quenched in water from 850°C, then aged at 450°C

Hardness: Rc 54.5

IMPACTOR

OFHC copper, 5.0 mm thick, backed with low-density polyurethane foam, mounted on 51-mm-diam aluminum alloy projectile

Impact velocity: 0.263 mm/ μs

TRANSDUCER Free-surface capacitor

Time: Relative

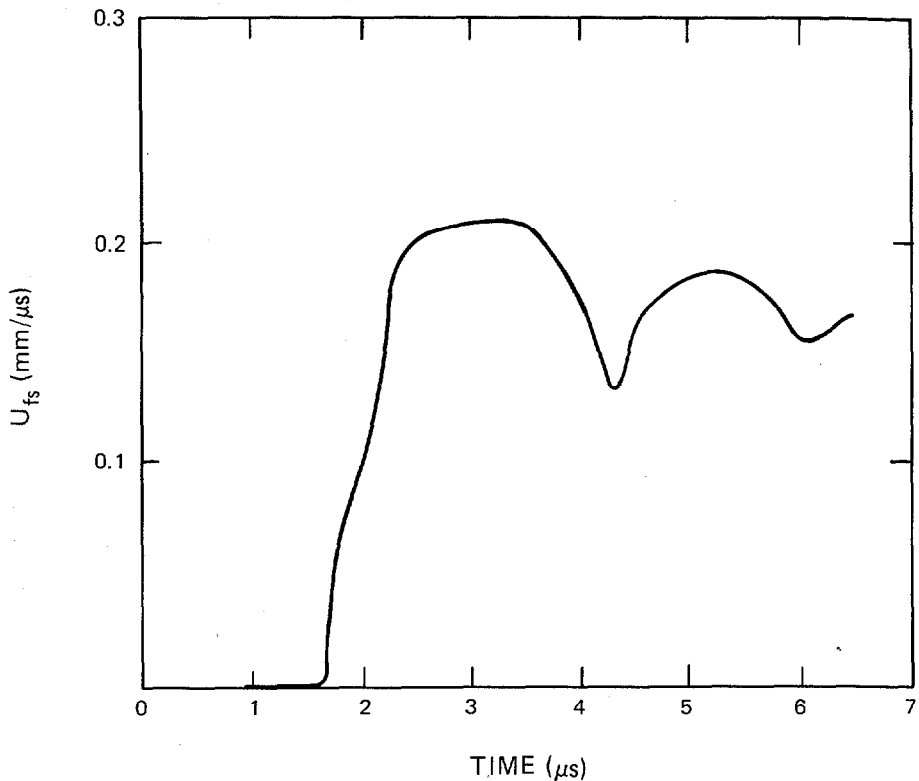

TARGET

Material: 99.17 wt% uranium with 0.83 wt% titanium
Experiment type: Free-surface capacitor
Experimenter: J. W. Hopson
Shot no.: 56-71-49 Date: December 7, 1971
Thickness: 9.70 mm Diameter: 38.1 mm
Density: 18.46 g/cm³
 $C_L = 3.44$ mm/ μ s $C_s = 2.10$ mm/ μ s
Heat treatment: Gamma-quenched in water from 850°C
Hardness: Rc 40.4

IMPACTOR

OFHC copper, 5.0 mm thick, backed with low-density polyurethane foam, mounted on 51-mm-diam aluminum alloy projectile
Impact velocity: 0.262 mm/ μ s

TRANSDUCER

Free-surface capacitor
Time: Relative

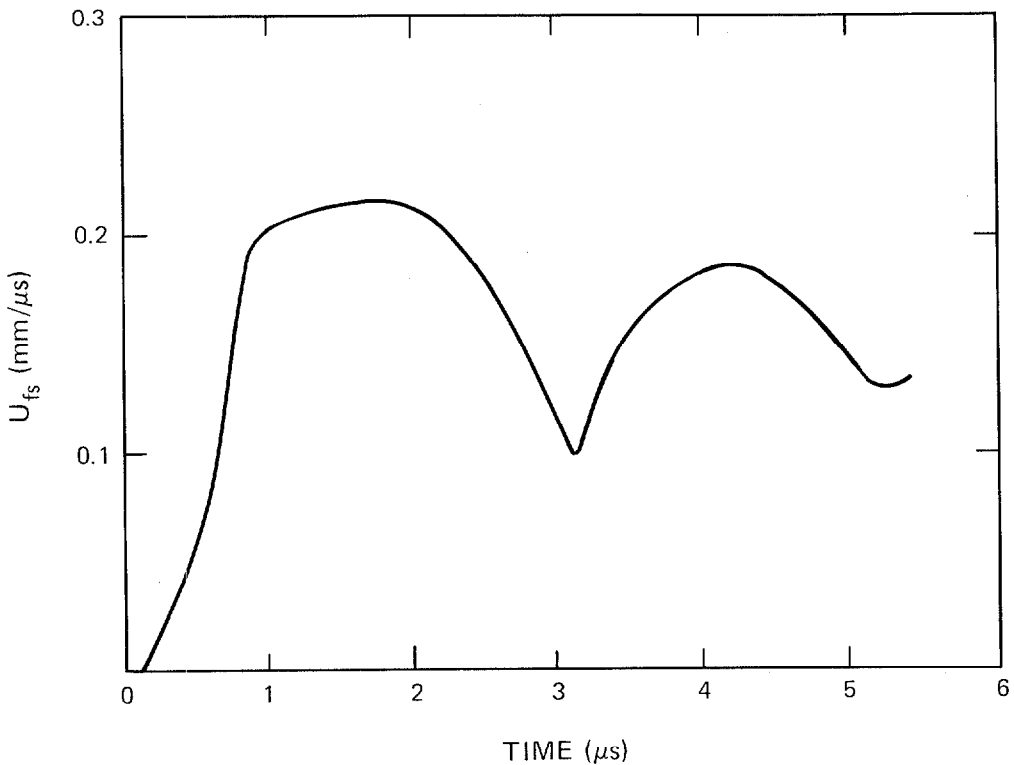

TARGET

Material: 98.83 wt% uranium with 1.17 wt% titanium

Experiment type: Free-surface capacitor

Experimenter: J. W. Hopson

Shot no.: 56-72-3 Date: January 5, 1972

Thickness: 9.70 mm Diameter: 38.1 mm

Density: 18.4 g/cm³

$C_L = 3.45$ mm/ μ s $C_S = 2.10$ mm/ μ s

Heat treatment: Gamma-quenched from 850°C to 500°C, aged at 500°C

Hardness: Rc 49.8

IMPACTOR

OFHC copper, 5.0 mm thick, backed with low-density polyurethane foam, mounted on 51-mm-diam aluminum alloy projectile

Impact velocity: 0.259 mm/ μ s

TRANSDUCER

Free-surface capacitor

Time: Relative

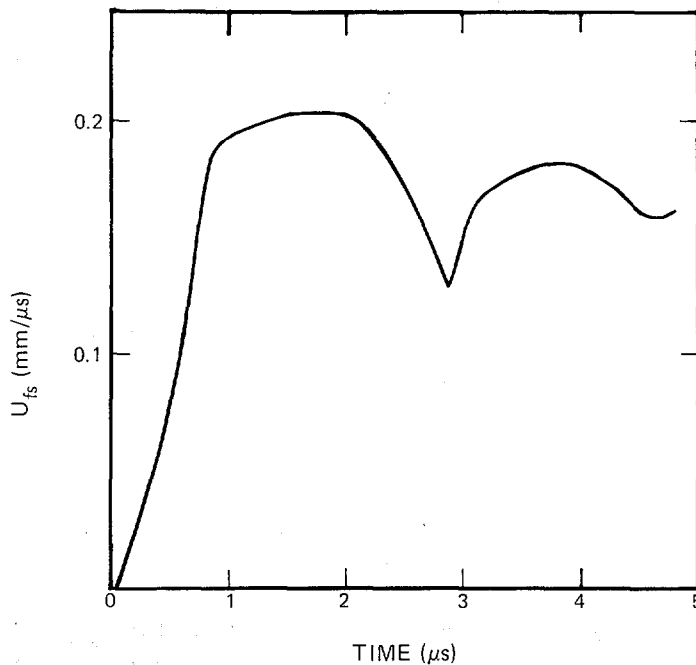

TARGET

Material: 98.82 wt% uranium with 1.18 wt% titanium
Experiment type: Free-surface capacitor
Experimenter: J. W. Hopson
Shot no.: 56-72-17 Date: February 8, 1972
Thickness: 9.32 mm Diameter: 38.1 mm
Density: 18.4 g/cm³
 $C_L = 3.45$ mm/ μ s $C_S = 2.10$ mm/ μ s
Heat treatment: Gamma-quenched from 850°C in water, aged
at 450°C
Hardness: Rc 49.8

IMPACTOR

OFHC copper, 5.0 mm thick, backed with low-density polyurethane
foam, mounted on 51-mm-diam aluminum alloy
projectile
Impact velocity: 0.262 mm/ μ s

TRANSDUCER

Free-surface capacitor
Time: Relative

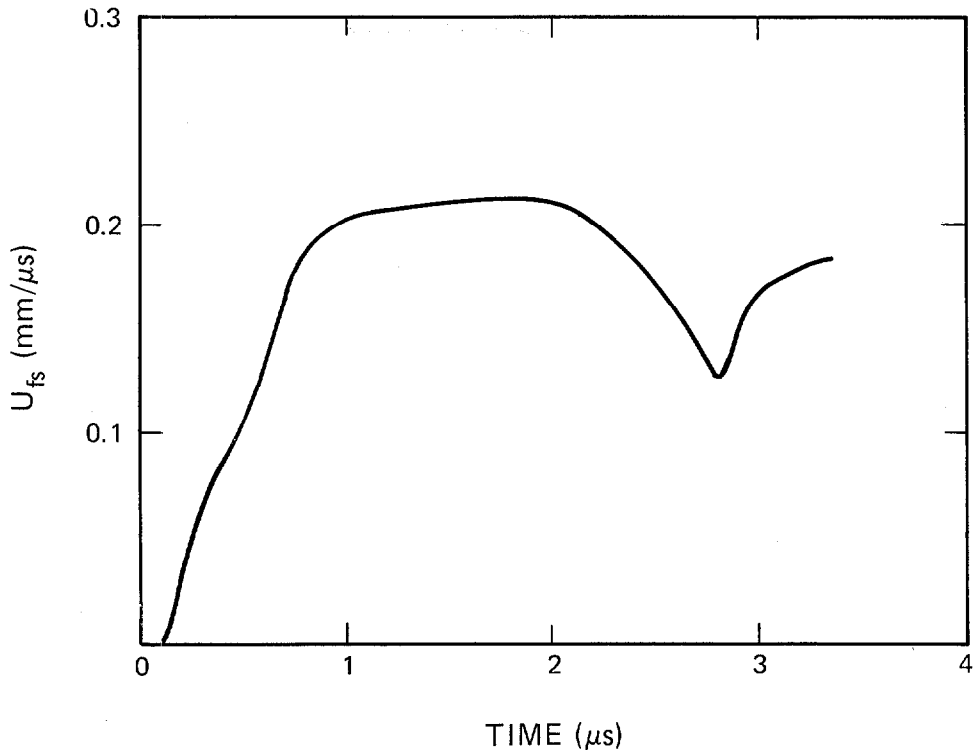

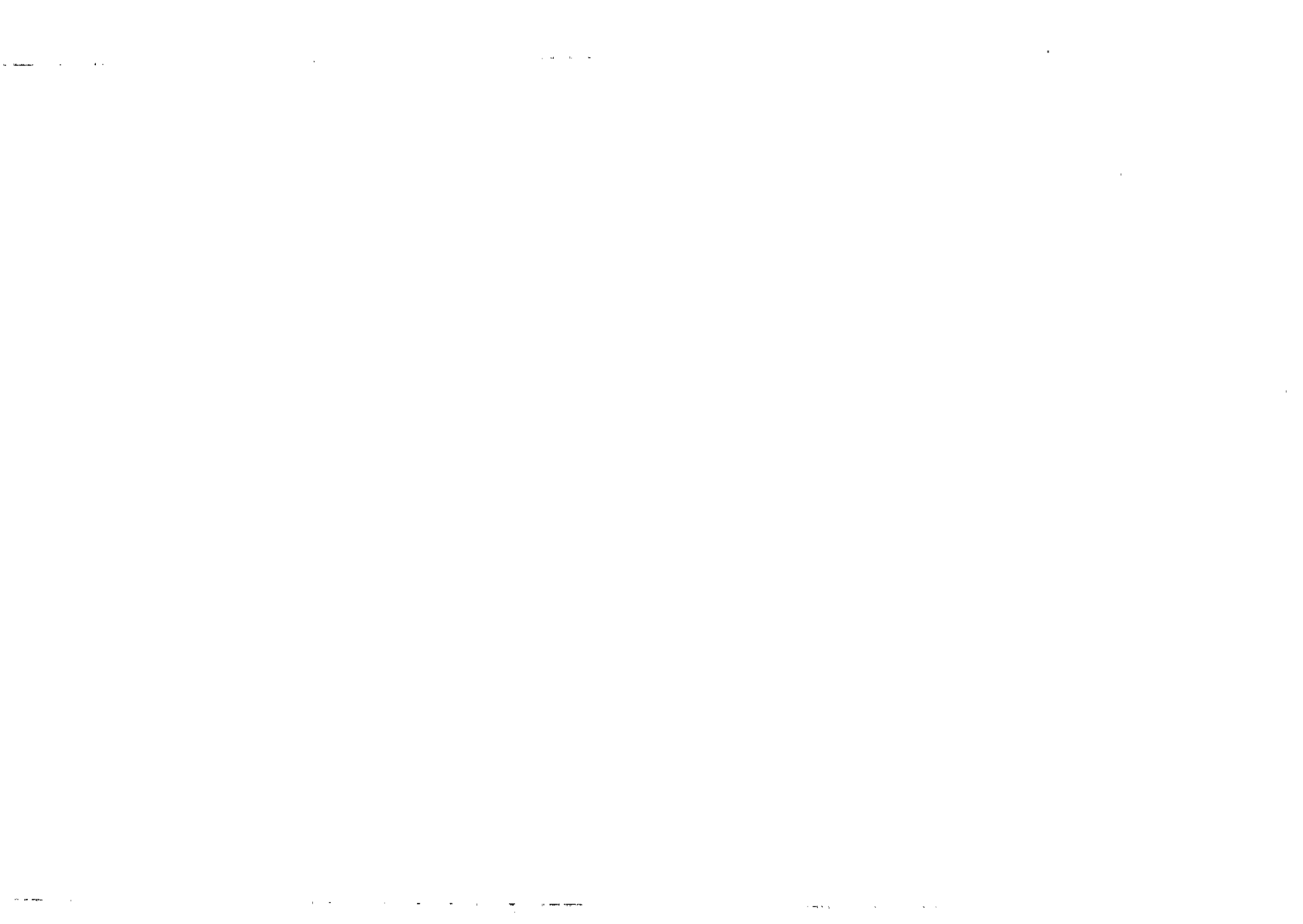

MINERALS AND COMPOUNDS

TARGET

Material: Alumina, Al_2O_3 (XA15)
Experiment type: Free-surface capacitor
Experimenter: J. W. Hopson
Shot no.: 56-70-23 Date: March 5, 1970
Thickness: 9.53 mm Diameter: 38.1 mm
Density: 3.12 g/cm^3
 $C_L = 6.77 \text{ mm}/\mu\text{s}$ $C_S = 4.28 \text{ mm}/\mu\text{s}$

IMPACTOR

Alumina (XA15), 4.54 mm thick, mounted on 51-mm-diam aluminum alloy projectile
Impact velocity: $0.424 \text{ mm}/\mu\text{s}$

TRANSDUCER

Free-surface capacitor
Time: Relative

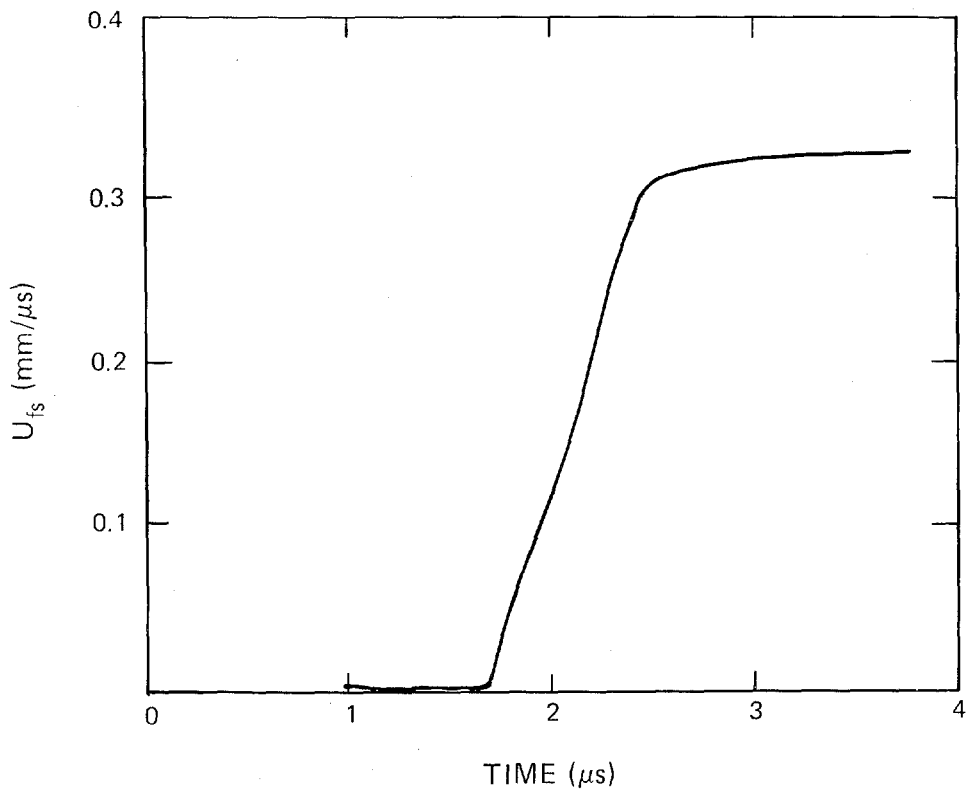

TARGET

Material: Alumina, Al_2O_3
Experiment type: Free-surface capacitor
Experimenter: J. W. Taylor
Reference: R. G. McQueen, S. P. Marsh, J. W. Taylor, J. N. Fritz,
and W. J. Carter (1970)
Shot no.: 56-67-440 Date: January 24, 1967
Thickness: 12.7 mm
Density: 3.39 g/cm^3
 $C_L = 8.72 \text{ mm}/\mu\text{s}$ $C_S = 5.15 \text{ mm}/\mu\text{s}$

IMPACTOR

2024 aluminum, 6.35 mm thick, mounted on aluminum alloy
projectile

TRANSDUCER

Free-surface capacitor
Time: Relative

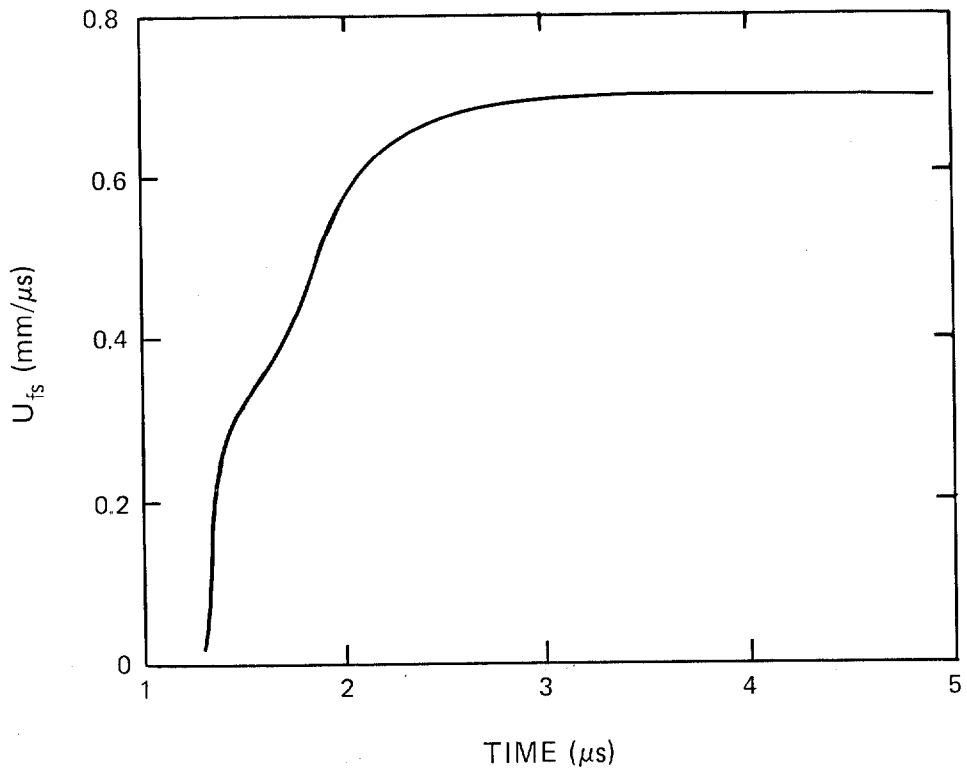

TARGET

Material: Alumina, Al_2O_3 (A1-8)
Experiment type: Free-surface capacitor
Experimenter: J. W. Hopson
Shot no.: 56A01 Date: July 31, 1968
Thickness: 12.95 mm Diameter: 38.1 mm
Density: 3.50 g/cm^3
 $C_L = 8.94 \text{ mm}/\mu\text{s}$

IMPACTOR

Alumina (A1-8), 6.35 mm thick, mounted on 51-mm-diam aluminum alloy projectile
Impact velocity: 0.386 $\text{mm}/\mu\text{s}$

TRANSDUCER

Free-surface capacitor
Time: Relative

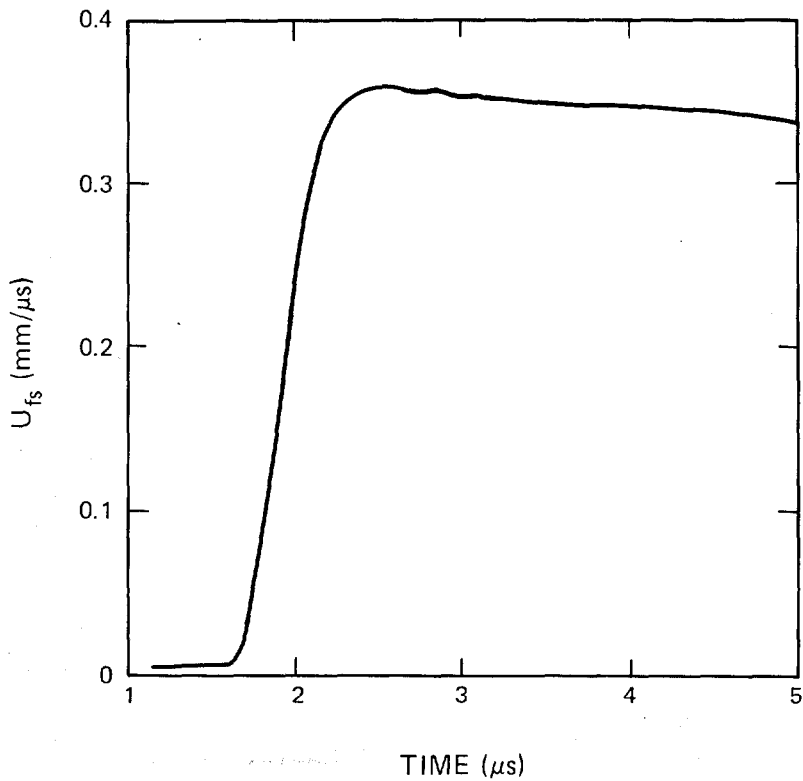

TARGET

Material: Alumina, Al_2O_3 (Al-8)
Experiment type: Free-surface capacitor
Experimenter: J. W. Hopson
Shot no.: 80A02 **Date:** August 9, 1968

HE SHOT GEOMETRY P-080 lens/102 mm baratol/2024 aluminum base plate/
12.71 mm alumina

SHOT COMPONENTS Alumina, Al_2O_3
Density: 3.50 g/cm^3
 $C_L = 8.94 \text{ mm}/\mu\text{s}$

TRANSDUCER Free-surface capacitor
Time: Relative

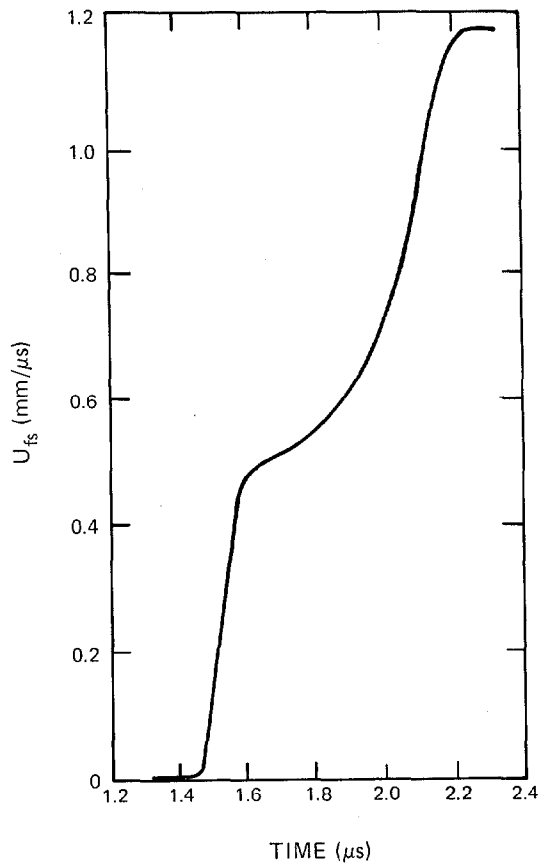

TARGET

Material: Beryllium oxide, BeO (Oak Ridge)
Experiment type: Free-surface capacitor
Experimenter: J. W. Hopson
Shot no.: 80205 **Date:** July 11, 1968

HE SHOT GEOMETRY

P-080 lens/51 mm baratol/2024 aluminum base plate/
12.67 mm beryllium oxide

SHOT COMPONENTS

Beryllium oxide, BeO
Density: 2.99 g/cm³
 $C_L = 11.90 \text{ mm}/\mu\text{s}$ $C_S = 7.28 \text{ mm}/\mu\text{s}$

TRANSDUCER

Free-surface capacitor
Time: Relative

NOTES

Shots 80205, 80211, and 80212 are a series with varied impact stress.

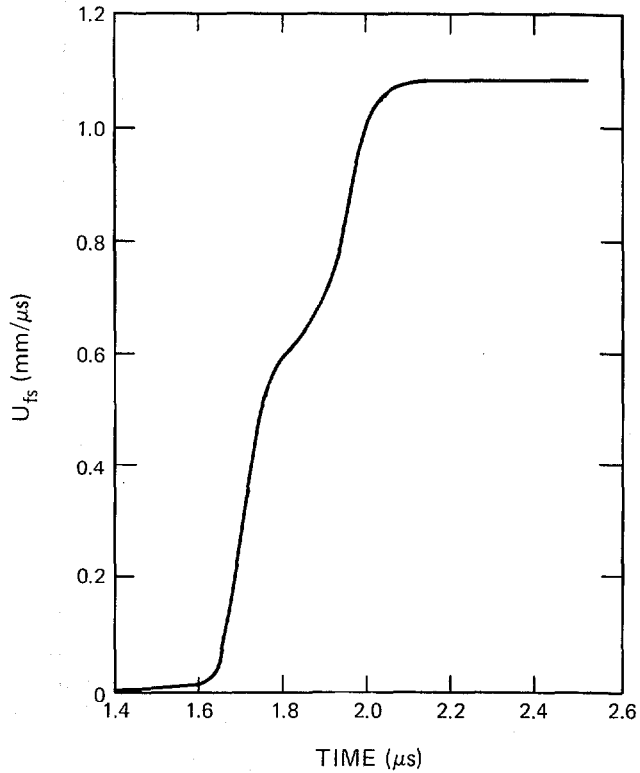

TARGET

Material: Beryllium oxide, BeO (Oak Ridge)
Experiment type: Free-surface capacitor
Experimenter: J. W. Hopson
Shot no.: 80211 **Date:** August 8, 1968

HE SHOT GEOMETRY P-080 lens/102 mm TNT/2024 aluminum base plate/
12.96 mm beryllium oxide

SHOT COMPONENTS Beryllium oxide, BeO
Density: 2.99 g/cm³
C_L = 11.90 mm/μs **C_S** = 7.28 mm/μs

TRANSDUCER Free-surface capacitor
Time: Relative

NOTES Shots 80205, 80211, and 80212 are a series with varied impact stress.

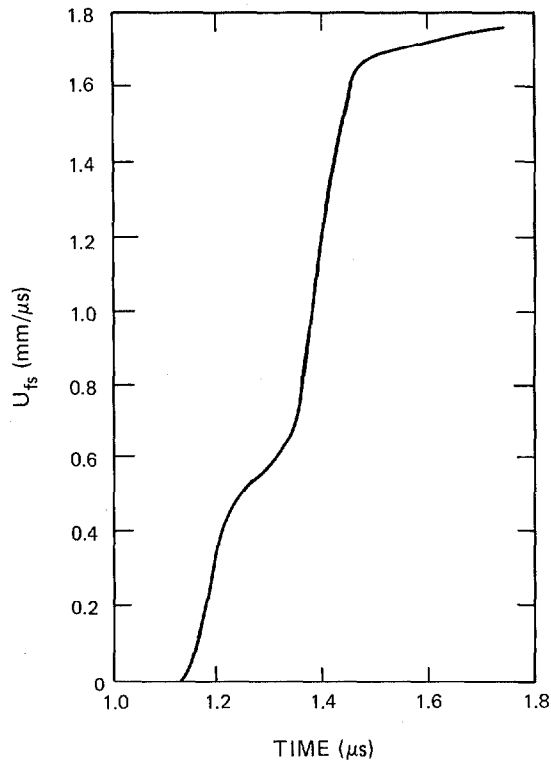

TARGET

Material: Beryllium oxide, BeO (Oak Ridge)

Experiment type: Free-surface capacitor

Experimenter: J. W. Hopson

Shot no.: 80212 **Date:** August 8, 1968

HE SHOT GEOMETRY

P-080 lens/102 mm Comp B/2024 aluminum base plate/
12.95 mm beryllium oxide

SHOT COMPONENTS

Beryllium oxide, BeO

Density: 2.99 g/cm³

$C_L = 11.90$ mm/ μ s $C_S = 7.28$ mm/ μ s

TRANSDUCER

Free-surface capacitor

Time: Relative

NOTES

Shots 80205, 80211, and 80212 are a series with varied impact stress.

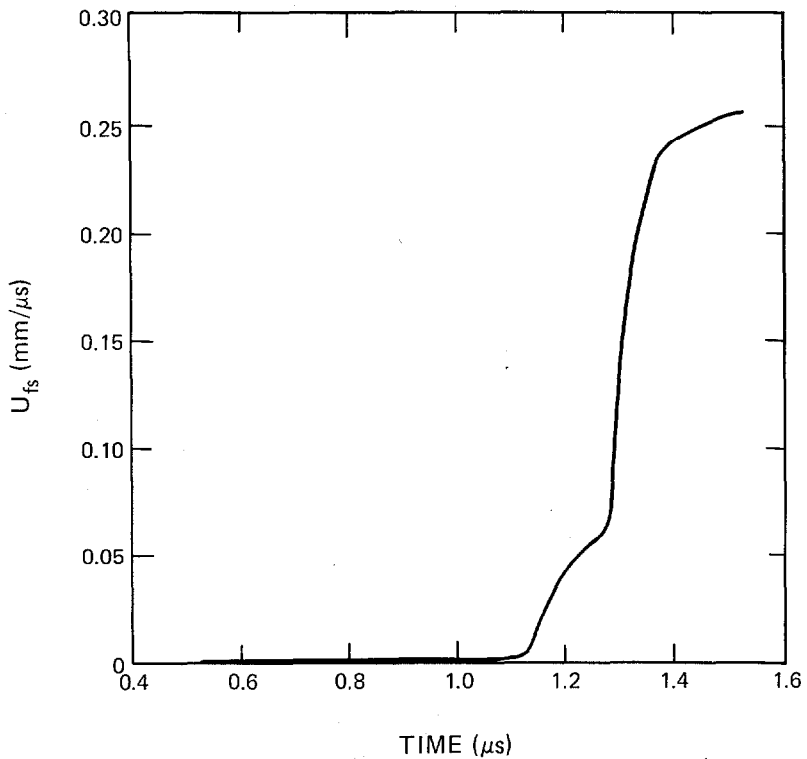

TARGET

Material: Beryllium oxide, BeO (Coors')
Experiment type: Free-surface capacitor
Experimenter: J. W. Hopson
Shot no.: 80209 **Date:** July 2, 1968

HE SHOT GEOMETRY

P-080 lens/51 mm baratol/2024 aluminum base plate/
12.34 mm beryllium oxide

SHOT COMPONENTS

Beryllium oxide, BeO
Density: 2.86 g/cm³
 $C_L = 11.45$ mm/ μ s $C_S = 7.02$ mm/ μ s

TRANSDUCER

Free-surface capacitor
Time: Relative

NOTES

Shots 80209 and 80210 are a series with varied impact stress.

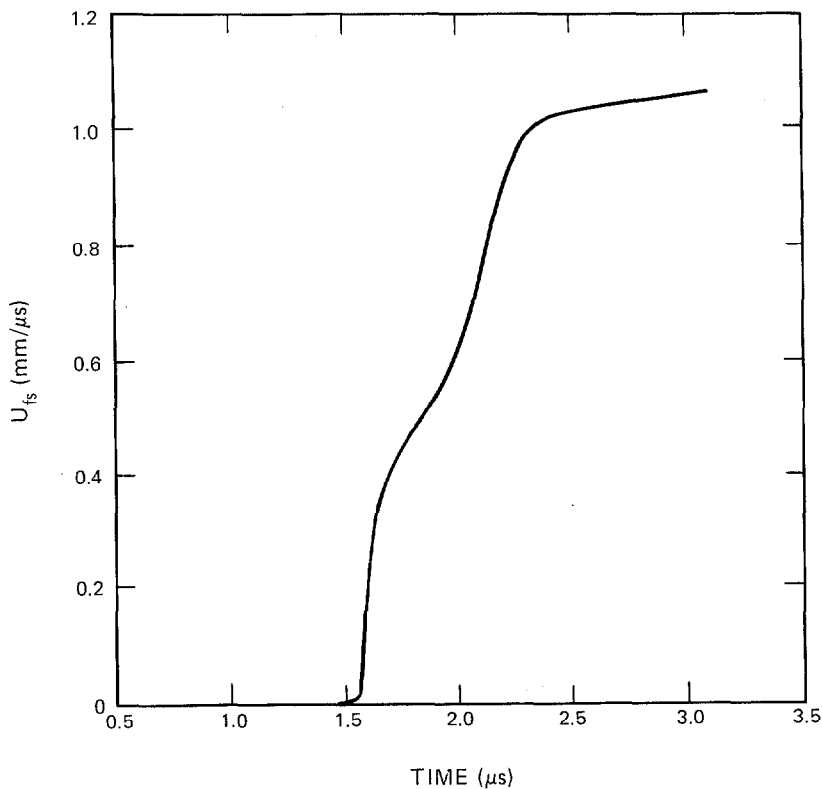

TARGET **Material:** Beryllium oxide, BeO (Coors')
 Experiment type: Free-surface capacitor
 Experimenter: J. W. Hopson
 Shot no.: 80210 **Date:** July 3, 1968

HE SHOT GEOMETRY P-080 lens/102 mm TNT/2024 aluminum base plate/
 12.36 mm beryllium oxide

SHOT COMPONENTS Beryllium oxide, BeO
 Density: 2.86 g/cm³
 $C_L = 11.45$ mm/ μ s $C_s = 7.02$ mm/ μ s

TRANSDUCER Free-surface capacitor
 Time: Relative

NOTES Shots 80209 and 80210 are a series with varied impact stress.

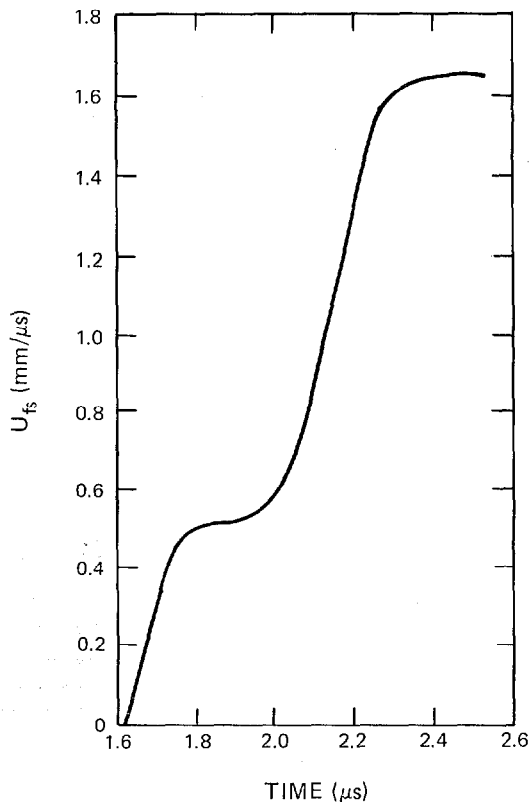

TARGET

Material: Boron carbide, B_4C
Experiment type: Free-surface capacitor
Experimenter: J. W. Hopson
Shot no.: 8BC01 Date: August 16, 1968

HE SHOT GEOMETRY

P-080 lens/102 mm TNT/2024 aluminum base plate/
7.75 mm boron carbide

SHOT COMPONENTS

Boron carbide
Density: 2.45 g/cm^3
 $C_L = 13.5 \text{ mm}/\mu\text{s}$ $C_S = 8.5 \text{ mm}/\mu\text{s}$

TRANSDUCER

Free-surface capacitor
Time: Relative

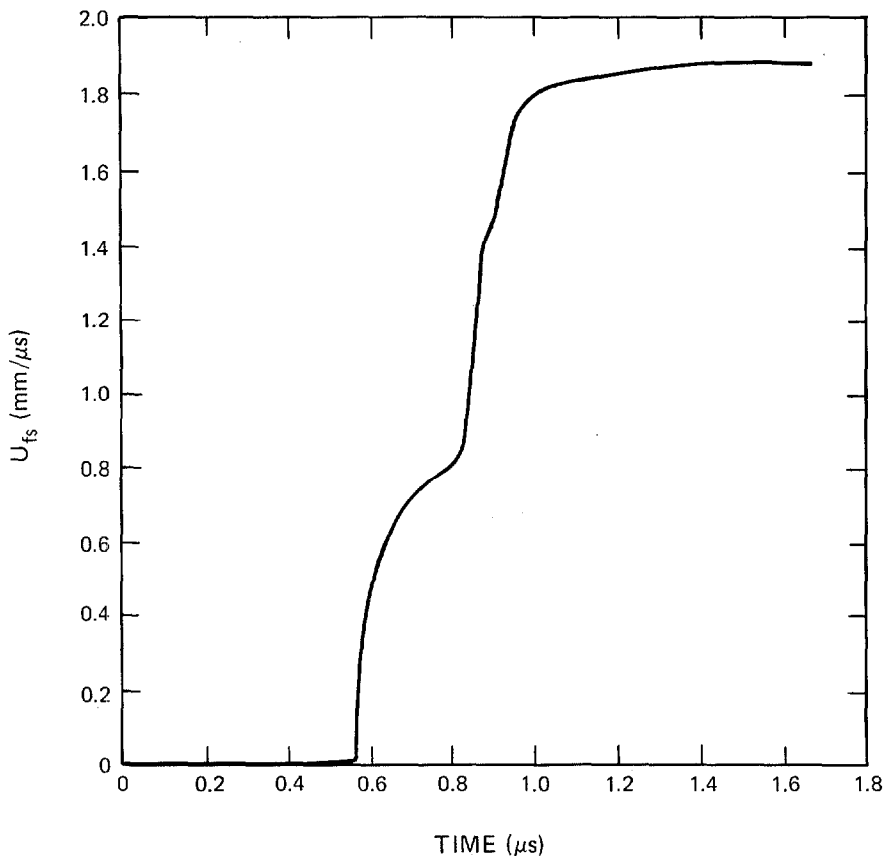

TARGET

Material: Boron carbide, B_4C
Experiment type: ASM probe
Experimenters: J. N. Fritz and J. A. Morgan
Shot no.: M 88 Date: September 13, 1973

HE SHOT GEOMETRY

P-081 lens/203 mm Comp B/8.32 mm boron carbide/
epoxy/0.03 mm aluminum//epoxy/8.31 mm boron carbide -f/
7.71 mm air//

TRANSDUCER

ASM probe
Coil radius: 28.64 mm Initial coil spacing: 16.02 mm
Time: Relative

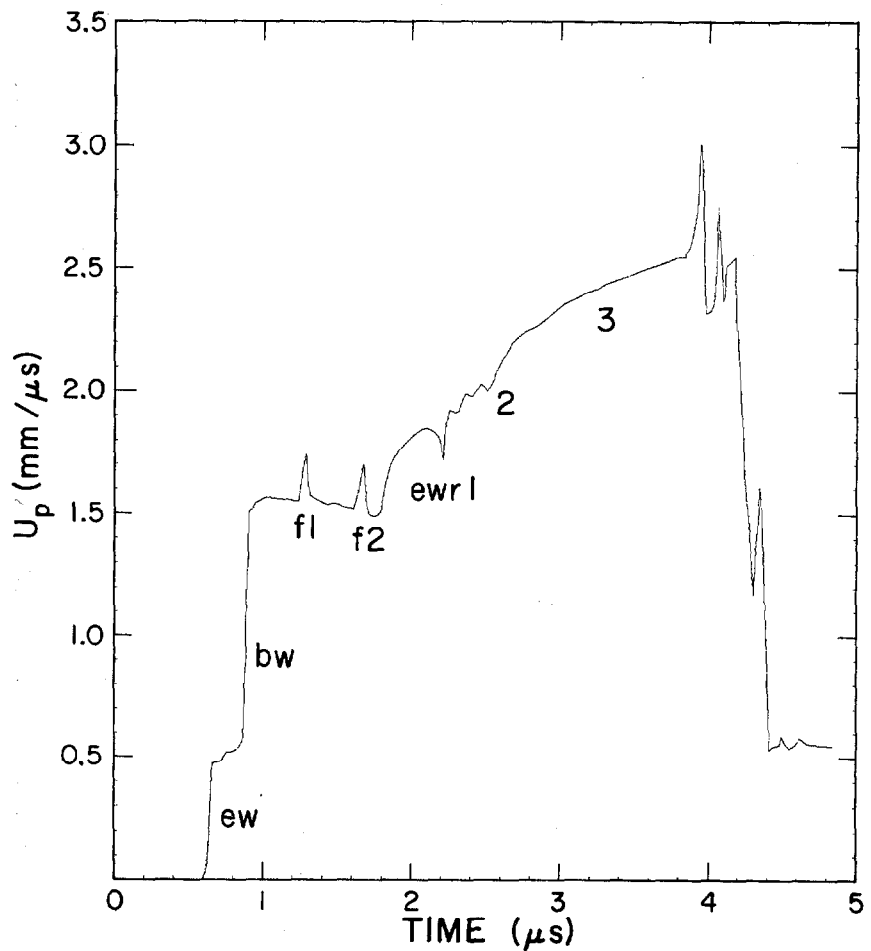

TARGET

Material: Boron carbide, B_4C
Experiment type: ASM probe
Experimenters: J. N. Fritz and J. A. Morgan
Shot no.: M 70 Date: August 30, 1972

HE SHOT GEOMETRY P-081 lens/203 mm Comp B/8.257 mm boron carbide/
0.03 mm aluminum, 0.025 mm air//8.312 mm boron
carbide -f/6.38 mm air//

TRANSDUCER

ASM probe
Coil radius: 28.64 mm, Initial coil spacing: 14.72 mm
Time: Relative

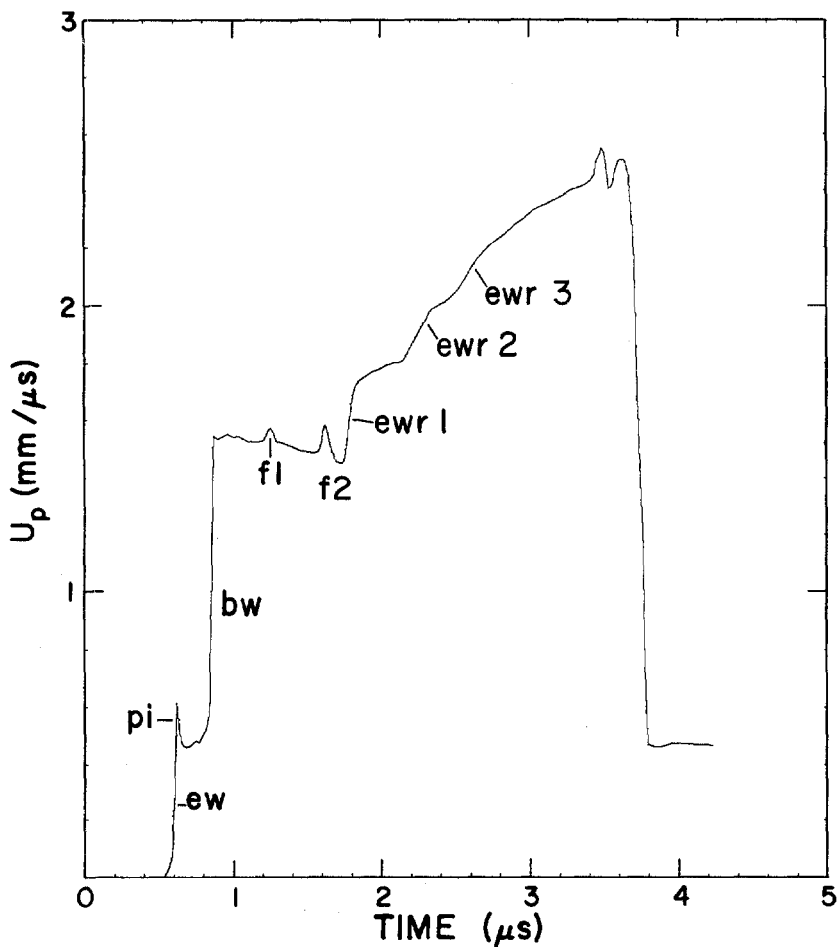

TARGET

Material: Boron carbide, B_4C
Experiment type: ASM probe
Experimenters: J. N. Fritz and J. A. Morgan
Shot no.: M 68 Date: July 7, 1972

HE SHOT GEOMETRY

P-081 lens/203 mm Comp B/12.78 mm 2024 aluminum//
8.43 mm boron carbide -f/5.02 mm air//

TRANSDUCER

ASM probe
Coil radius: 28.64 mm Initial coil spacing: 13.45 mm
Time: Relative

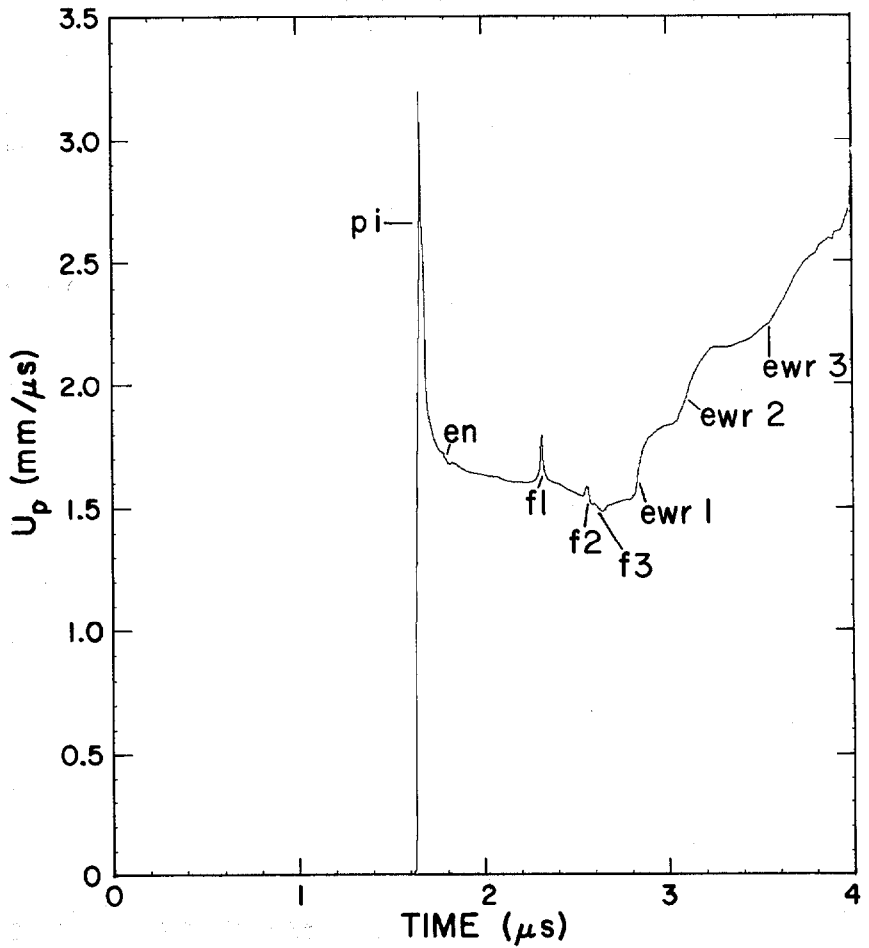

TARGET

Material: Boron carbide, B₄C
Experiment type: ASM probe
Experimenters: J. N. Fritz and J. A. Morgan
Shot no.: M 84 Date: May 1, 1973

HE SHOT GEOMETRY

P-081 lens/229 mm octol/8.23 mm boron carbide/epoxy/
0.03 mm aluminum//epoxy/8.29 mm boron carbide -f/
7.71 mm air//

TRANSDUCER

ASM probe
Coil radius: 28.64 mm Initial coil spacing: 16.00 mm
Time: Relative

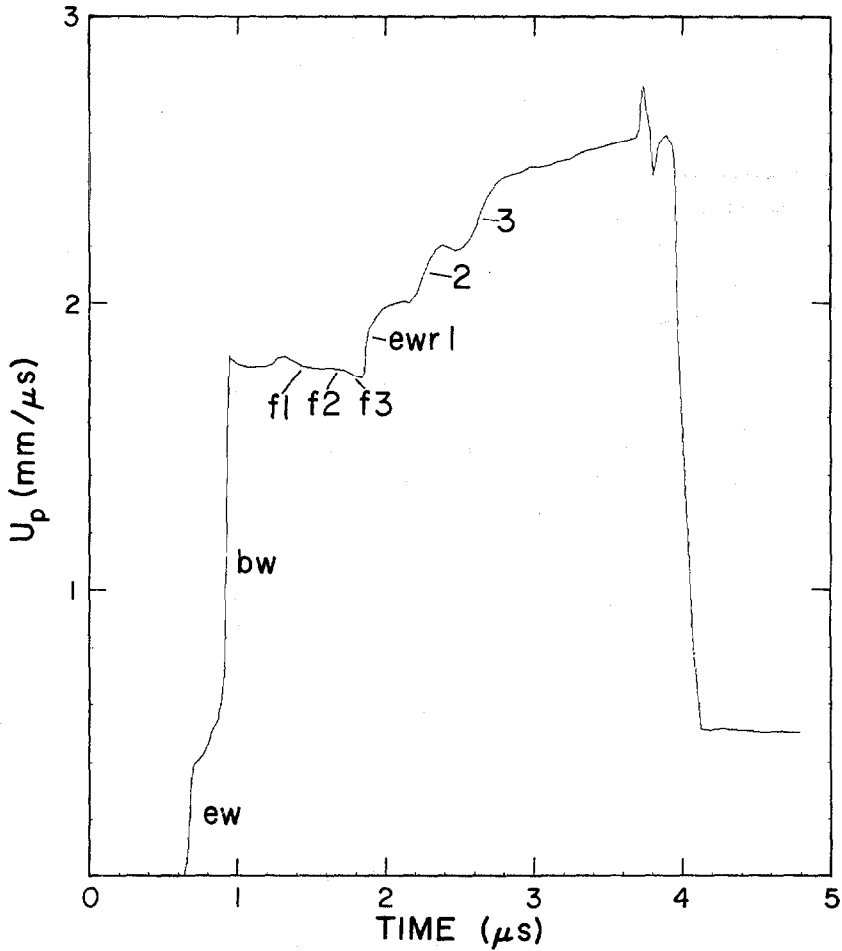

TARGET

Material: Boron carbide, B₄C
Experiment type: ASM probe
Experimenters: J. N. Fritz and J. A. Morgan
Shot no.: M 83 Date: April 30, 1973

HE SHOT GEOMETRY

P-081 lens/229 mm octol/8.27 mm boron carbide/epoxy/
0.03 mm aluminum//epoxy/8.43 mm boron carbide -f/
7.71 mm air//

TRANSDUCER

ASM probe
Coil radius: 28.64 mm Initial coil spacing: 16.14 mm
Time: Relative

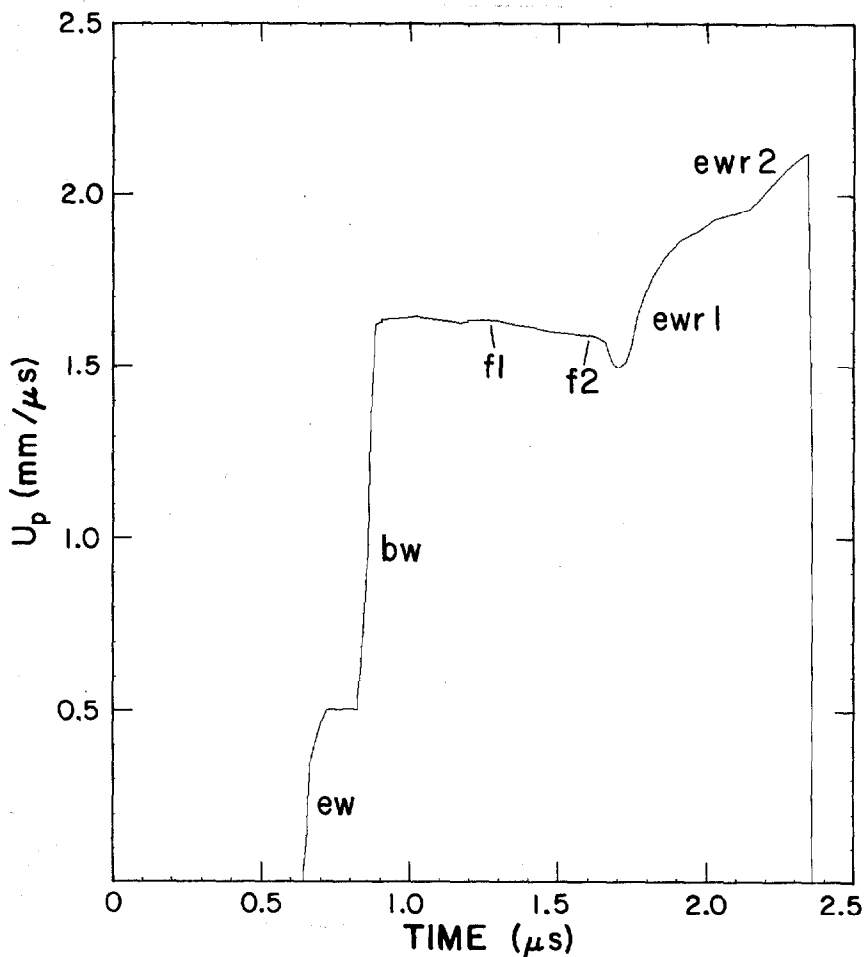

TARGET

Material: Boron carbide, B_4C
Experiment type: ASM probe
Experimenters: J. N. Fritz and J. A. Morgan
Shot no.: M 74 **Date:** August 31, 1972

HE SHOT GEOMETRY

P-081 lens/229 mm octol/7.51 mm boron carbide/0.03 mm aluminum, 0.046 mm air//8.42 mm boron carbide -f/ 6.41 mm air//

TRANSDUCER

ASM probe
Coil radius: 28.64 mm **Initial coil spacing:** 14.88 mm
Time: Relative

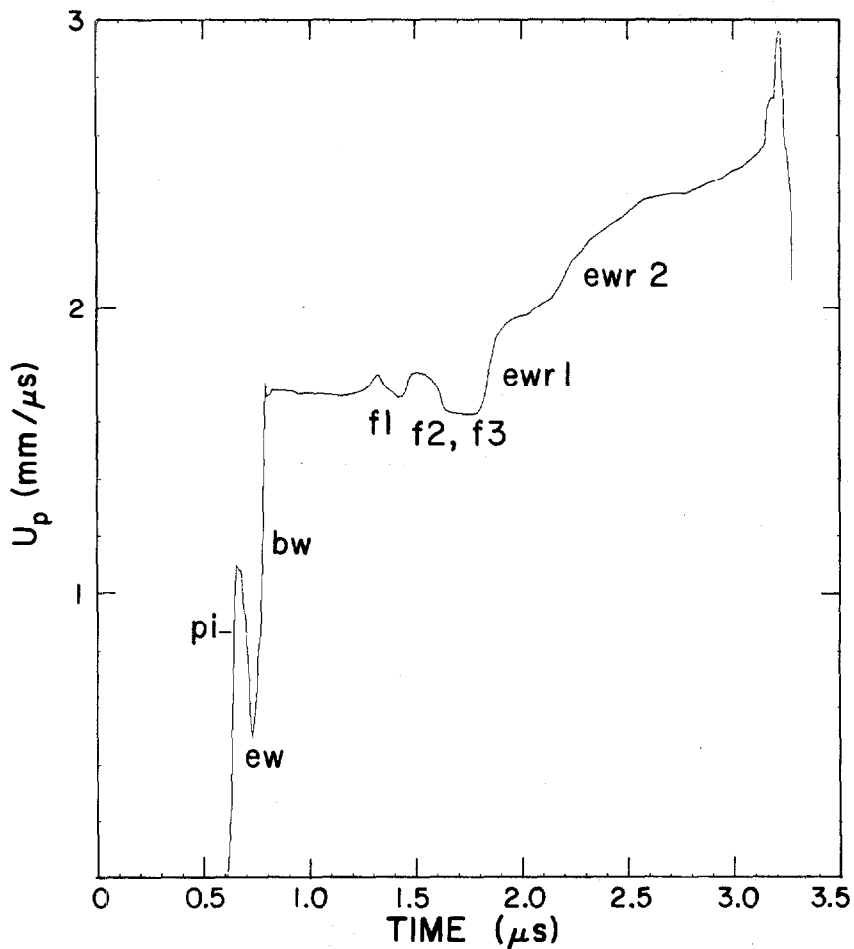

TARGET

Material: Boron carbide, B₄C
Experiment type: ASM probe
Experimenters: J. N. Fritz and J. A. Morgan
Shot no.: M 89 Date: September 26, 1973

HE SHOT GEOMETRY

P-081 lens/229 mm octol/8.26 mm boron carbide/
epoxy/0.03 mm aluminum//epoxy/8.27 mm boron carbide -f/
10.12 mm air//

TRANSDUCER

ASM probe
Coil radius: 28.64 mm Initial coil spacing: 18.39 mm
Time: Relative

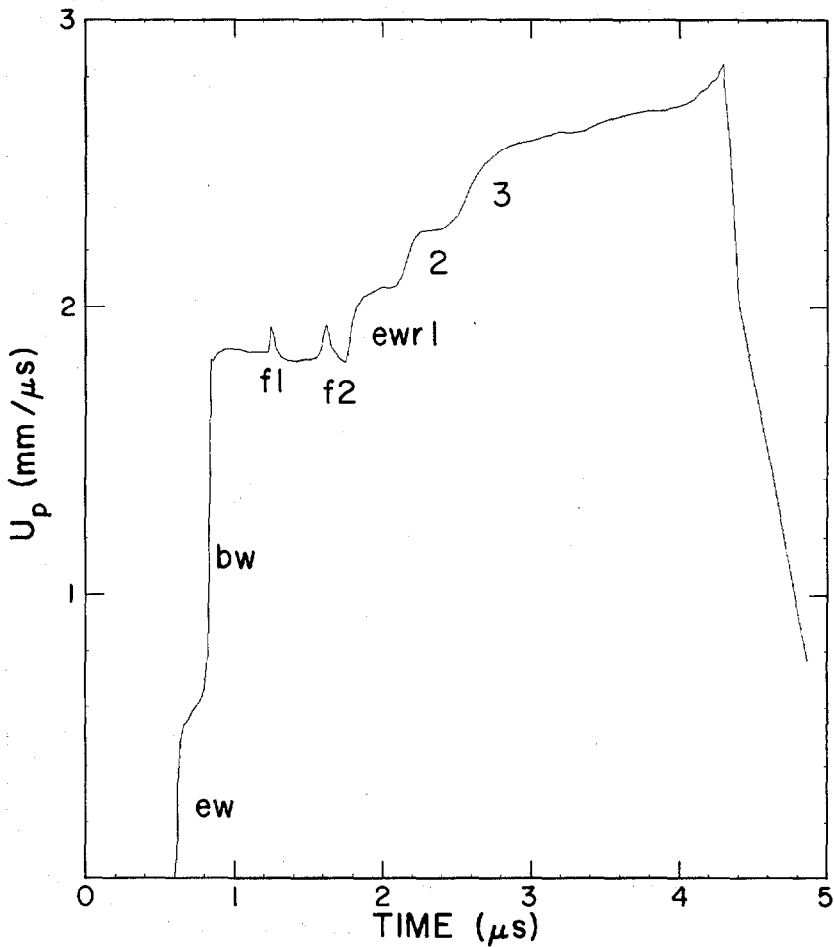

TARGET

Material: Boron carbide, B₄C
Experiment type: ASM probe
Experimenters: J. N. Fritz and J. A. Morgan
Shot no.: M 90 Date: September 27, 1973

HE SHOT GEOMETRY

P-081 lens/152 mm PBX 9404/7.90 mm boron carbide/
epoxy/0.03 mm aluminum//epoxy/8.20 mm boron carbide -f/
10.15 air//

TRANSDUCER

ASM probe
Coil radius: 28.64 mm Initial coil spacing: 18.35 mm
Time: Relative

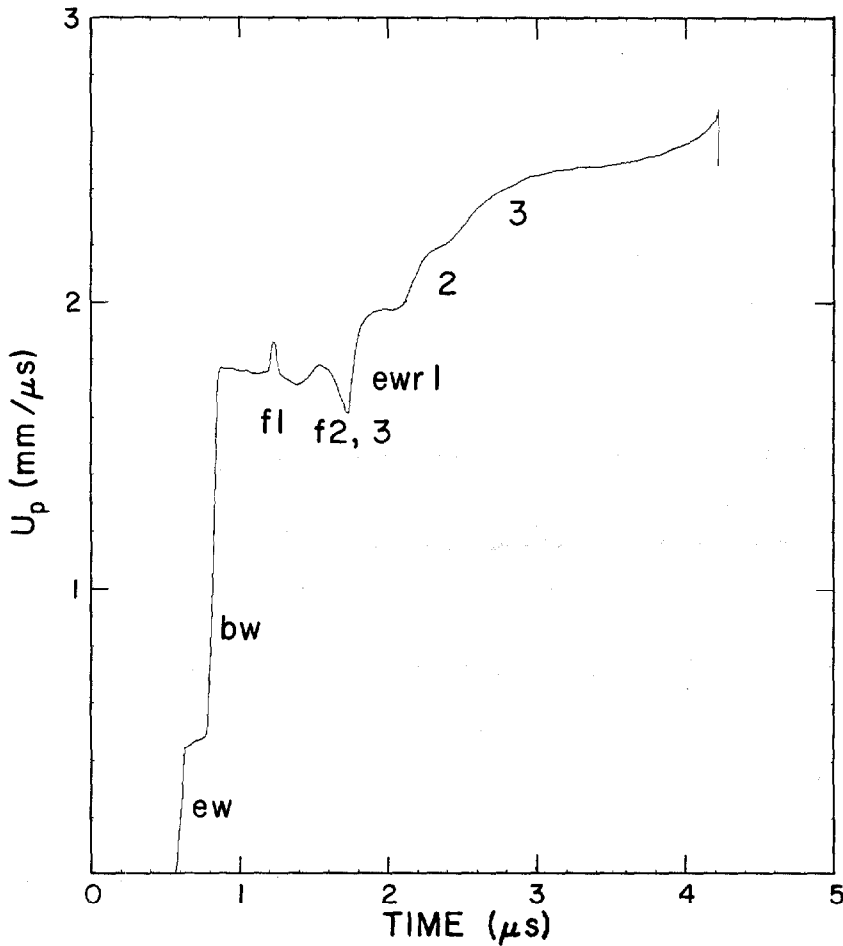

TARGET

Material: Boron carbide, B_4C
Experiment type: ASM probe
Experimenters: J. N. Fritz and J. A. Morgan
Shot no.: M 86 Date: June 14, 1973

HE SHOT GEOMETRY

P-081 lens/152 mm PBX 9404/8.25 mm boron carbide/
epoxy/0.03 mm aluminum//epoxy/8.30 mm boron carbide -f/
6.38 mm air//

TRANSDUCER

ASM probe
Coil radius: 28.64 mm Initial coil spacing: 14.68 mm
Time: Relative

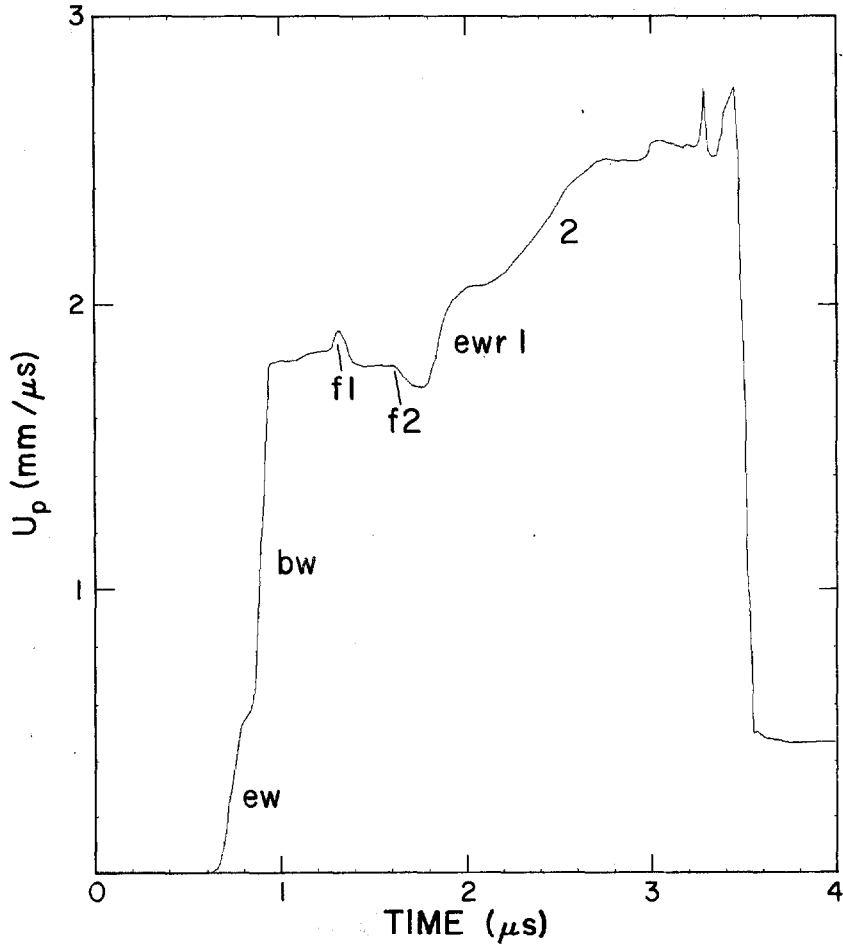

TARGET Material: Boron nitride, BN
Experiment type: Free-surface capacitor
Experimenter: J. W. Taylor
Reference: R. G. McQueen, S. P. Marsh, J. W. Taylor,
J. N. Fritz, and W. J. Carter (1970)
Shot no.: 56-66-408 Date: December 22, 1966
Thickness: 12.70 mm
Density: 2.02 g/cm³

IMPACTOR 2024 aluminum mounted on aluminum alloy projectile
Impact velocity: 0.301 mm/ μ s

TRANSDUCER Free-surface capacitor
Time: Relative

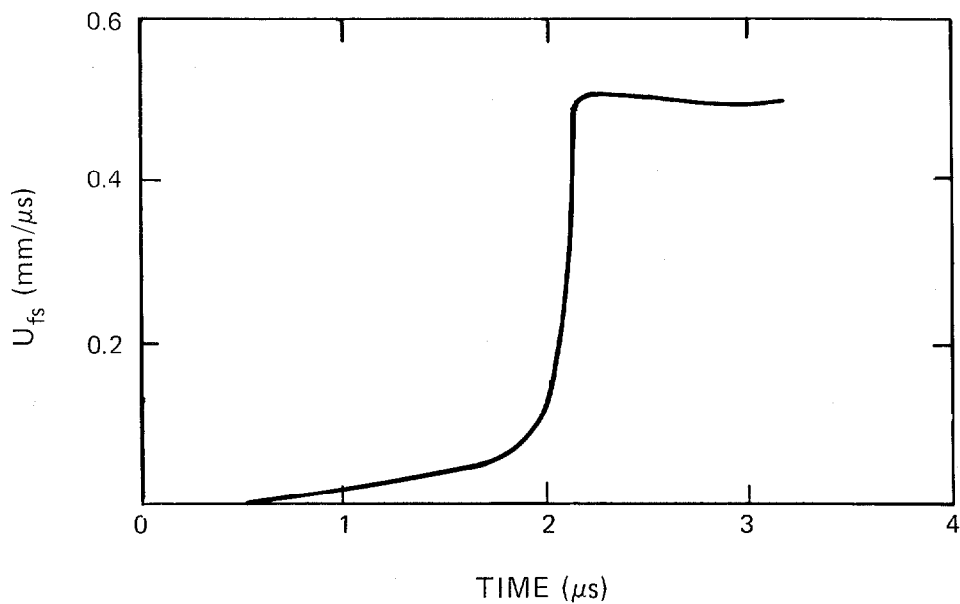

TARGET

Material: Calcium carbonate, CaCO_3
Experiment type: Free-surface capacitor
Experimenter: J. W. Hopson
Shot no.: 8B690 **Date:** April 6, 1970

HE SHOT GEOMETRY

P-080 lens/102 mm baratol/2024 aluminum base plate/
8.74 mm calcium carbonate

SHOT COMPONENTS

Calcium carbonate
Density: 2.63 g/cm^3

TRANSDUCER

Free-surface capacitor
Time: Relative

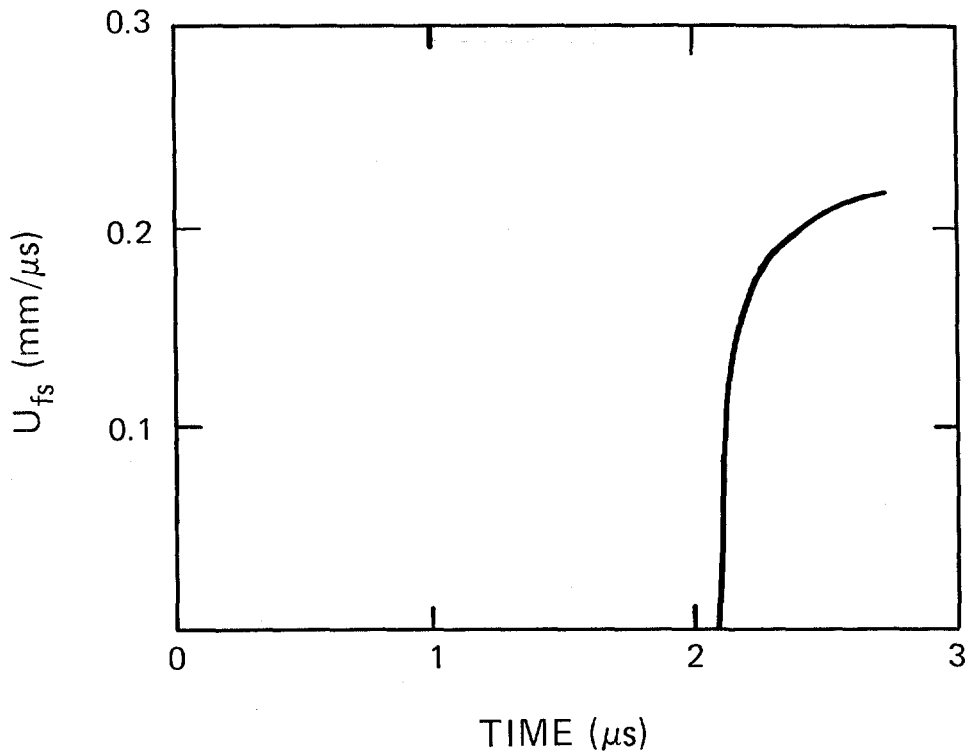

TARGET

Material: Hafnium titanate, HfTiO_3
Experiment type: Free-surface capacitor
Experimenter: J. W. Hopson
Shot no.: 8B625 Date: May 14, 1969

HE SHOT GEOMETRY

P-080 lens/102 mm baratol/2024 aluminum base plate/
12.71 mm hafnium titanate

SHOT COMPONENTS

Hafnium titanate
Density: 6.97 g/cm^3
 $C_L = 2.28 \text{ mm}/\mu\text{s}$

TRANSDUCER

Free-surface capacitor
Time: Relative

NOTES

Shots 50-70-22 and 8B625 are a series with varied impact stress.

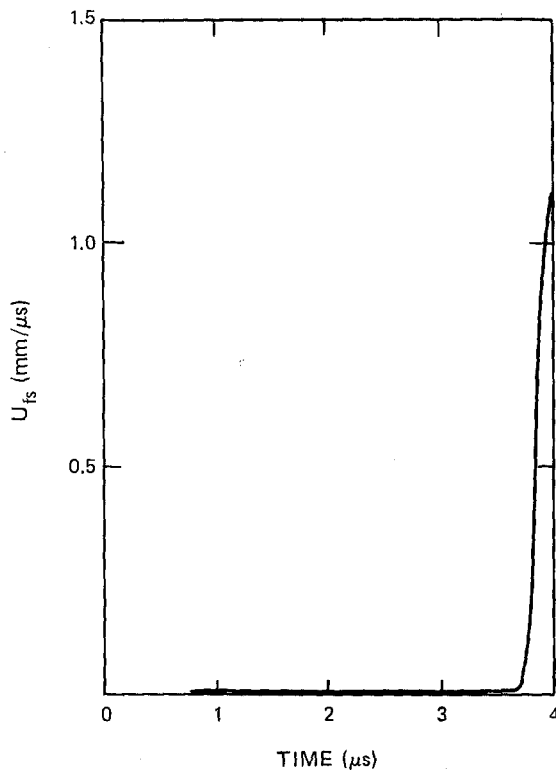

TARGET Material: Hafnium titanate, HfTiO_3
Experiment type: Free-surface capacitor
Experimenter: J. W. Hopson
Shot no.: 50-70-22 Date: February 27, 1970
Thickness: 12.72 mm
Density: 6.96 g/cm^3
 $C_L = 2.28 \text{ mm}/\mu\text{s}$

IMPACTOR 2024 aluminum, 6.35 mm thick, mounted on aluminum alloy
projectile
Impact velocity: 0.39 $\text{mm}/\mu\text{s}$

TRANSDUCER Free-surface capacitor
Time: Relative

NOTES Shots 50-70-22 and 8B625 are a series with varied impact
stress.

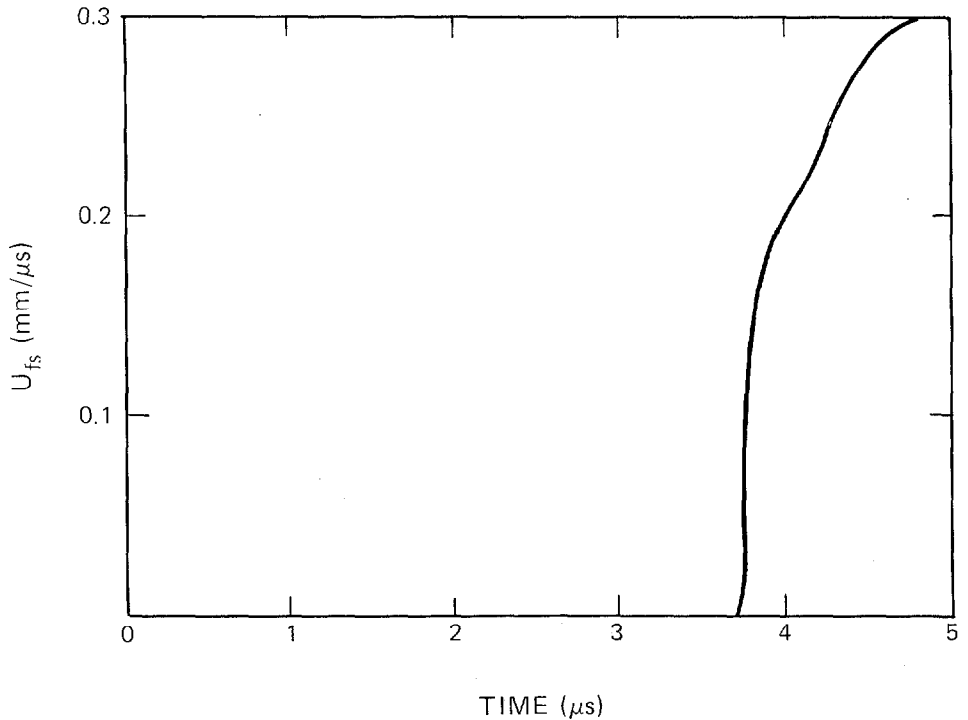

TARGET

Material: Lithium hydride, ${}^6\text{LiH}$
Experiment type: Free-surface capacitor
Experimenter: J. W. Taylor
Shot no.: 56-63-276 **Date:** October 10, 1963
Thickness: 12.7 mm
Density: 0.669 g/cm^3
 $C_L = 11.1 \text{ mm}/\mu\text{s}$

IMPACTOR

Lithium hydride, 6.35 mm thick, mounted on aluminum alloy projectile
Impact velocity: $0.138 \text{ mm}/\mu\text{s}$

TRANSDUCER

Free-surface capacitor
Time: Relative

NOTES

Shots 56-63-276, 56-64-315, and 56-64-316 are a series with varied target thickness.

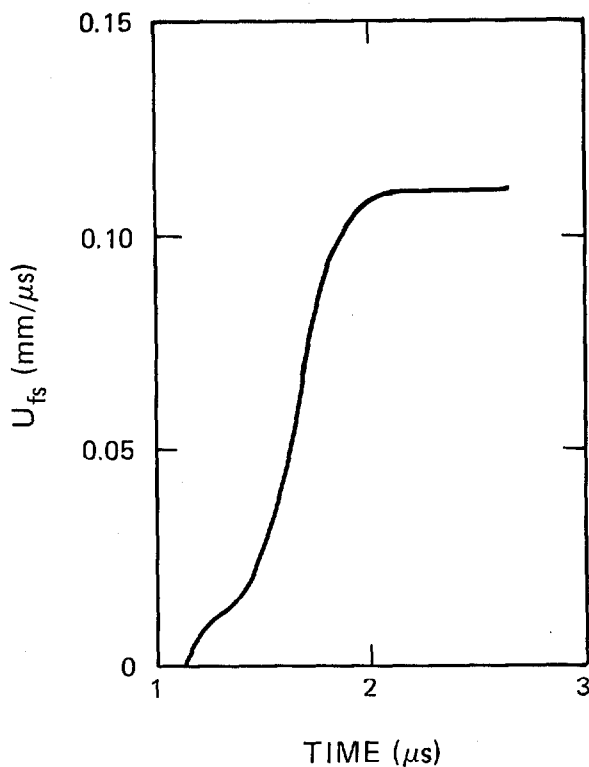

TARGET

Material: Lithium hydride, ${}^6\text{LiH}$
Experiment type: Free-surface capacitor
Experimenter: J. W. Taylor
Shot no.: 56-64-315 Date: August 11, 1964
Thickness: 25.4 mm Diameter: 153 mm
Density: 0.666 g/cm^3
 $C_L = 10.4 \text{ mm}/\mu\text{s}$ $C_S = 6.86 \text{ mm}/\mu\text{s}$

IMPACTOR

OFHC copper, mounted on 165-mm-diam aluminum alloy projectile

TRANSDUCER

Free-surface capacitor
Time: Relative

NOTES

Shots 56-63-276, 56-64-315, and 56-64-316 are a series with varied target thickness.

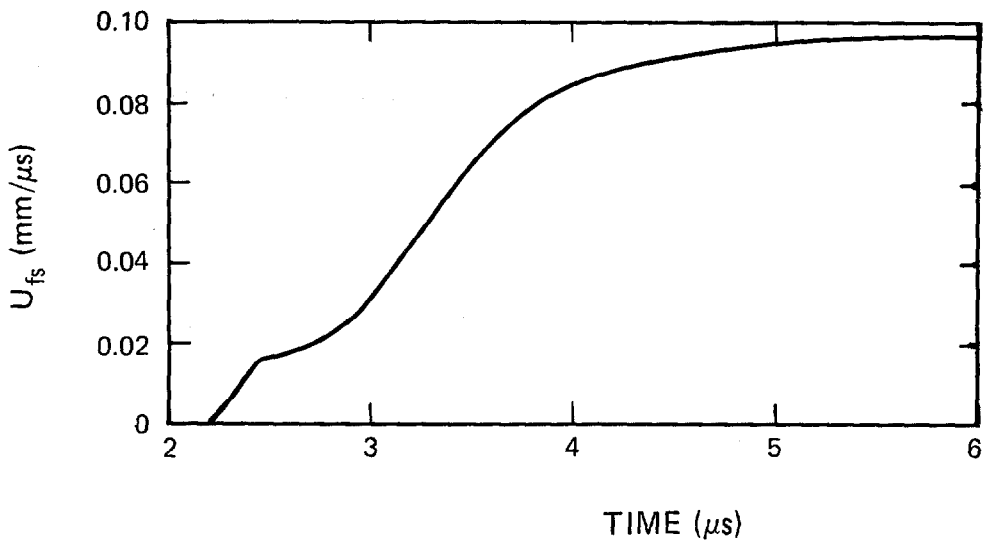

TARGET**Material:** Lithium hydride, ${}^6\text{LiH}$ **Experiment type:** Free-surface capacitor**Experimenter:** J. W. Taylor**Shot no.:** 56-64-316 **Date:** August 13, 1964**Thickness:** 50.80 mm **Diameter:** 153 mm**Density:** 0.66 g/cm³ $C_L = 10.4 \text{ mm}/\mu\text{s}$ $C_S = 6.86 \text{ mm}/\mu\text{s}$ **IMPACTOR**

OFHC copper, mounted on 165-mm-diam aluminum alloy projectile

TRANSDUCER

Free-surface capacitor

Time: Relative**NOTES**

Shots 56-63-276, 56-64-315, and 56-64-316 are a series with varied target thickness.

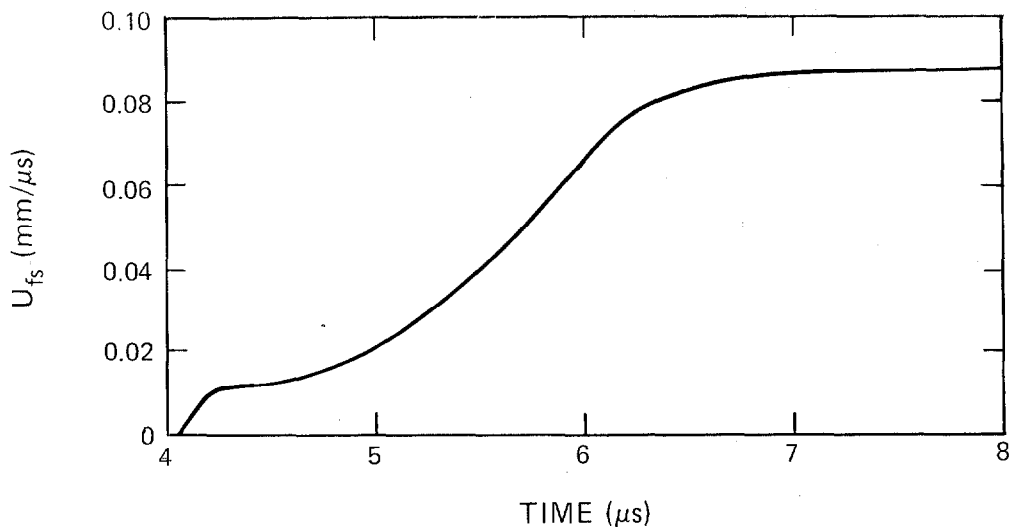

TARGET

Material: Lithium hydride, ${}^6\text{LiH}$, at 115°C
Experiment type: Free-surface capacitor
Experimenter: J. W. Taylor
Shot no.: 56-64-292 **Date:** May 11, 1964
Thickness: 12.70 mm **Diameter:** 153 mm
Density: 0.666 g/cm^3
 $C_L = 10.4\text{ mm}/\mu\text{s}$ $C_S = 6.86\text{ mm}/\mu\text{s}$

IMPACTOR

OFHC copper, mounted on 165-mm-diam aluminum alloy projectile

TRANSDUCER

Free-surface capacitor
Time: Relative

NOTES

Shots 56-64-292, 56-64-309, and 56-64-314 are a series with varied ambient temperatures.

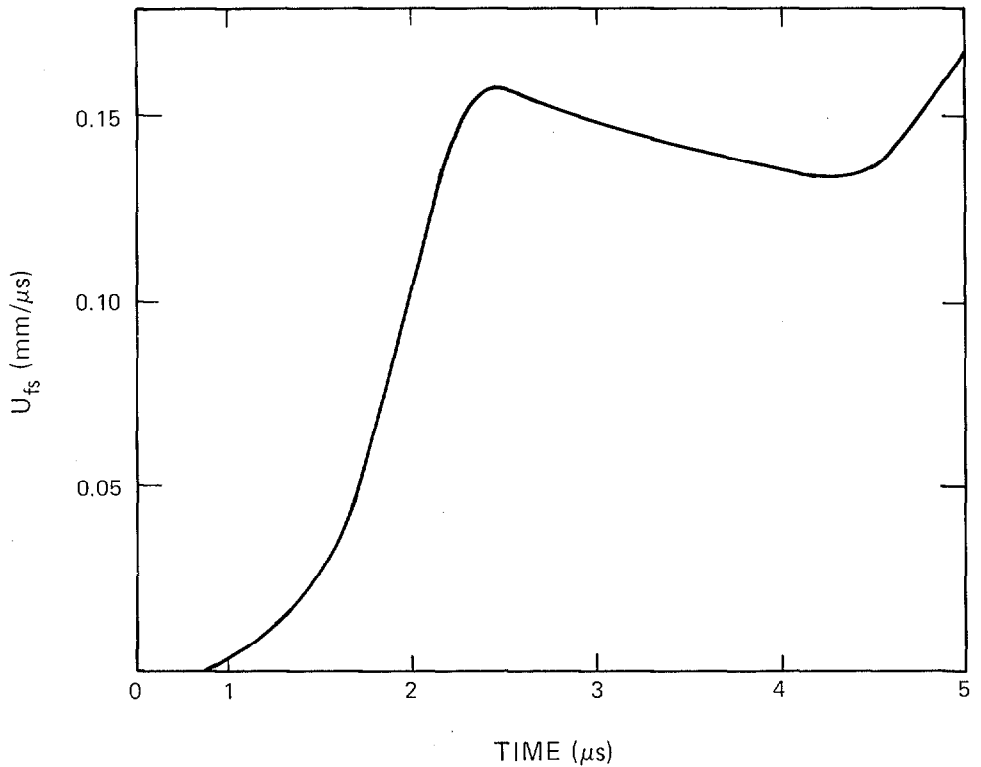

TARGET **Material:** Lithium hydride, ${}^6\text{LiH}$, at 210°C
Experiment type: Free-surface capacitor
Experimenter: J. W. Taylor
Shot no.: 56-64-309 **Date:** July 28, 1964
Thickness: 12.70 mm
Density: 0.666 g/cm^3
 $C_L = 10.4 \text{ mm}/\mu\text{s}$ $C_S = 6.86 \text{ mm}/\mu\text{s}$

IMPACTOR OFHC copper, mounted on 165-mm-diam aluminum alloy projectile

TRANSDUCER Free-surface capacitor
Time: Relative

NOTES Shots 56-64-292, 56-64-309, and 56-64-314 are a series with varied ambient temperatures.

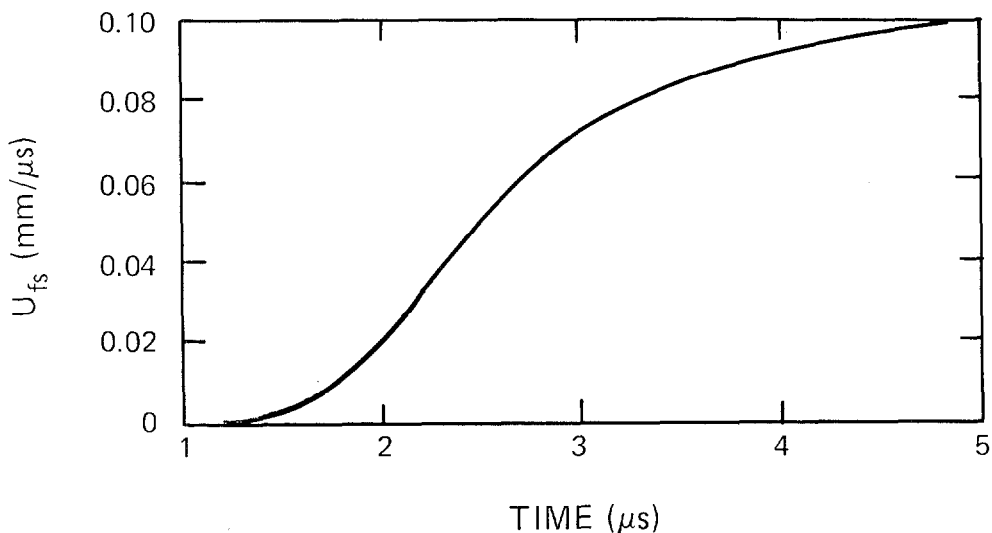

TARGET

Material: Lithium hydride, ${}^6\text{LiH}$, at 360°C

Experiment type: Free-surface capacitor

Experimenter: J. W. Taylor

Shot no.: 56-64-314 Date: August 13, 1964

Thickness: 12.7 mm Diameter: 153 mm

Density: 6.66 g/cm^3

$C_L = 10.4 \text{ mm}/\mu\text{s}$ $C_S = 6.86 \text{ mm}/\mu\text{s}$

IMPACTOR

OFHC copper disk, mounted on aluminum alloy projectile

TRANSDUCER

Free-surface capacitor

Time: Relative

NOTES

Shots 56-64-292, 56-64-309, and 56-64-314 are a series with varied target thickness.

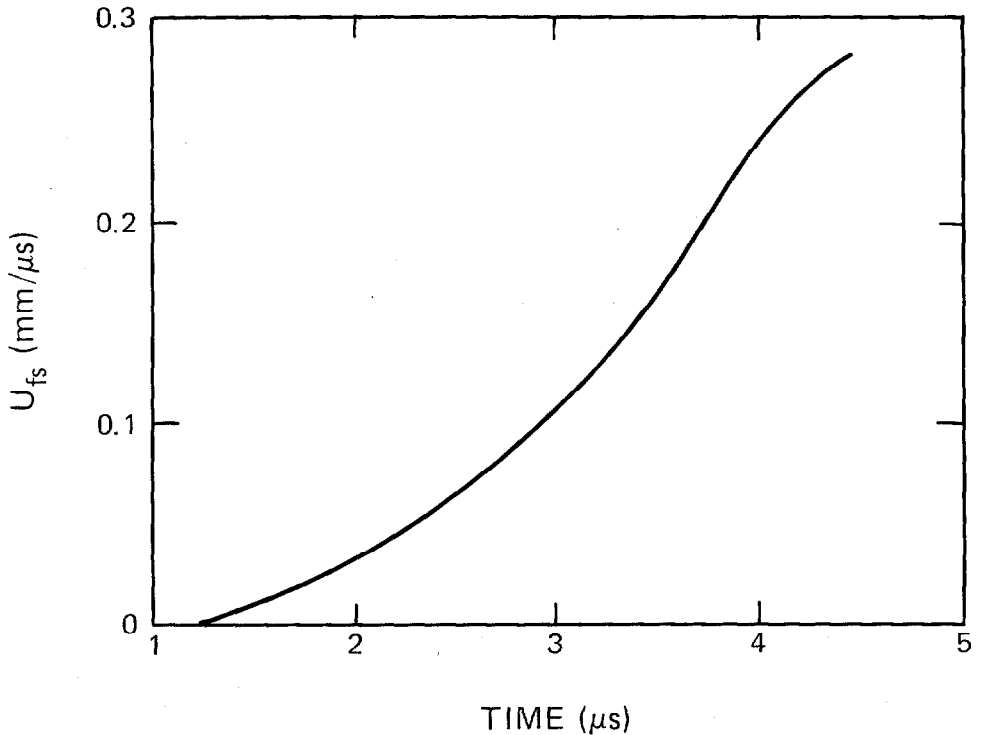

TARGET

Material: Sodium chloride, NaCl (pressed polycrystalline sample)

Experiment type: ASM probe

Experimenters: J. N. Fritz and J. A. Morgan

Shot no.: M 63 **Date:** April 19, 1972

HE SHOT GEOMETRY

P-081 lens/102 mm Comp B/8.944 mm OFHC copper//
5.03 mm sodium chloride -f/5.06 mm air//

SHOT COMPONENTS

OFHC copper

Density: 8.93 g/cm³

C_L = 4.76 mm/μs C_S = 2.33 mm/μs

TRANSDUCER

ASM probe

Coil radius: 28.64 mm Initial coil spacing: 10.09 mm

Time: Relative

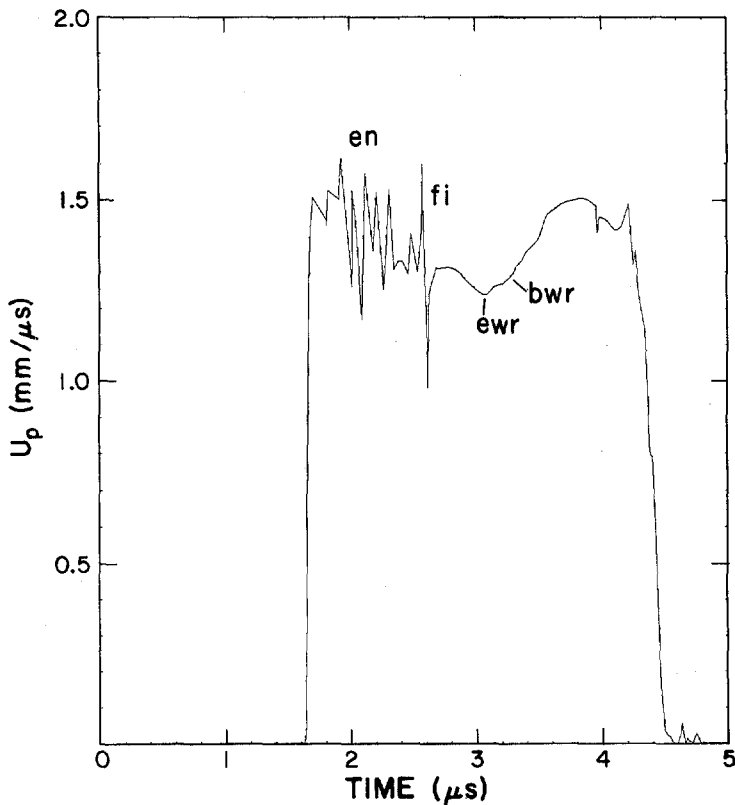

TARGET **Material:** Sodium chloride, NaCl (pressed polycrystalline sample)
Experiment type: ASM probe
Experimenters: J. N. Fritz and J. A. Morgan
Shot no.: M 65 **Date:** April 21, 1972

HE SHOT GEOMETRY P-081 lens/102 mm TNT/12.76 mm 2024 aluminum//
f- 5.01 mm sodium chloride -f/5.05 mm air//

SHOT COMPONENTS 2024 aluminum
Density: 2.785 g/cm³
C_L = 6.36 mm/μs **C_S** = 3.16 mm/μs

TRANSDUCER ASM probe
Coil radius: 28.64 mm **Initial coil spacing:** 10.06 mm
Time: Relative

NOTES For shielding, a 75-nm aluminum film was deposited on both faces of the sodium chloride sample and was grounded to the aluminum base plate.

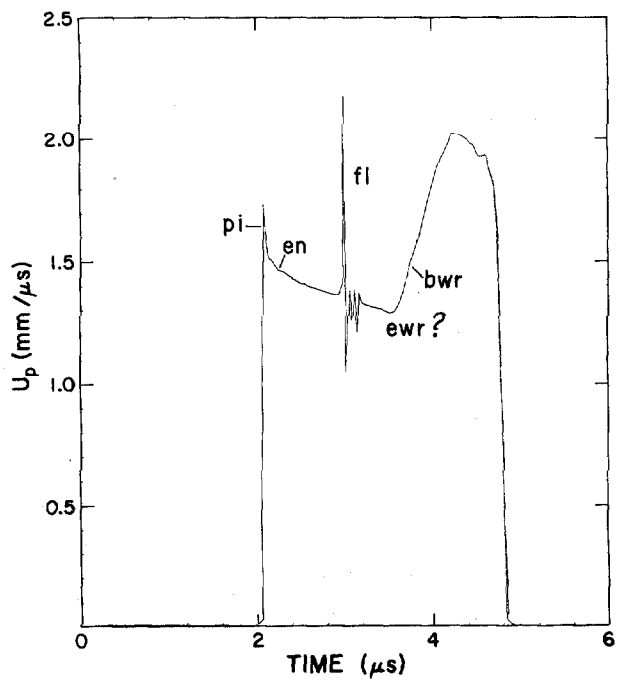

TARGET

Material: Sodium chloride, NaCl (pressed polycrystalline sample)

Experiment type: ASM probe

Experimenters: J. N. Fritz and J. A. Morgan

Reference: J. N. Fritz and J. A. Morgan (1973)

Shot no.: M 66 **Date:** May 1, 1972

HE SHOT GEOMETRY

P-081 lens/102 mm TNT/9.38 mm OFHC copper//
f- 5.04 mm sodium chloride -f/5.04 mm air//

SHOT COMPONENTS

OFHC copper

Density: 8.93 g/cm³

$C_L = 4.76$ mm/ μ s $C_S = 2.33$ mm/ μ s

TRANSDUCER

ASM probe

Coil radius: 28.64 mm **Initial coil spacing:** 10.09 mm

Time: Relative

NOTES

For shielding, a 75-nm aluminum film was deposited on both faces of the sodium chloride sample and was grounded to the aluminum base plate.

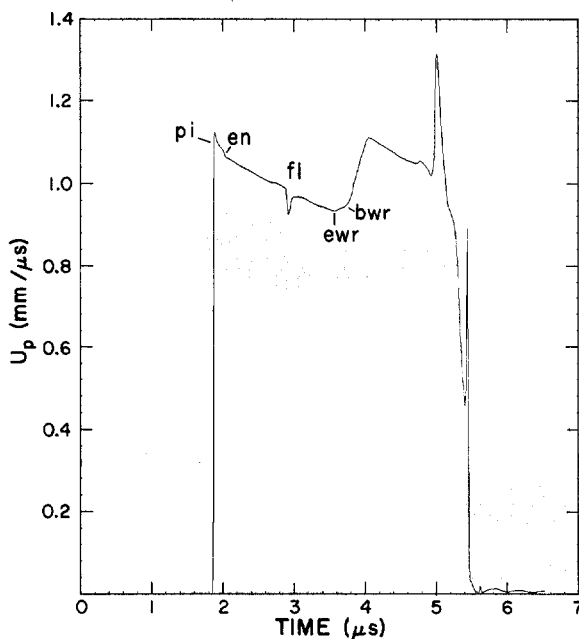

TARGET **Material:** Sodium chloride, NaCl (pressed polycrystalline sample)
Experiment type: ASM probe
Experimenters: J. N. Fritz and J. A. Morgan
Shot no.: M 67 **Date:** May 5, 1972

HE SHOT GEOMETRY P-081 lens/203 mm TNT/12.67 mm OFHC copper//
f- 5.04 mm sodium chloride -f/5.04 mm air//

SHOT COMPONENTS OFHC copper
Density: 8.93 g/cm³
C_L = 4.76 mm/μs **C_S** = 2.33 mm/μs

TRANSDUCER ASM probe
Coil radius: 28.64 mm **Initial coil spacing:** 10.09 mm
Time: Relative

NOTES For shielding, a 75-nm aluminum film was deposited on both faces of the sodium chloride sample and was grounded to the aluminum base plate.

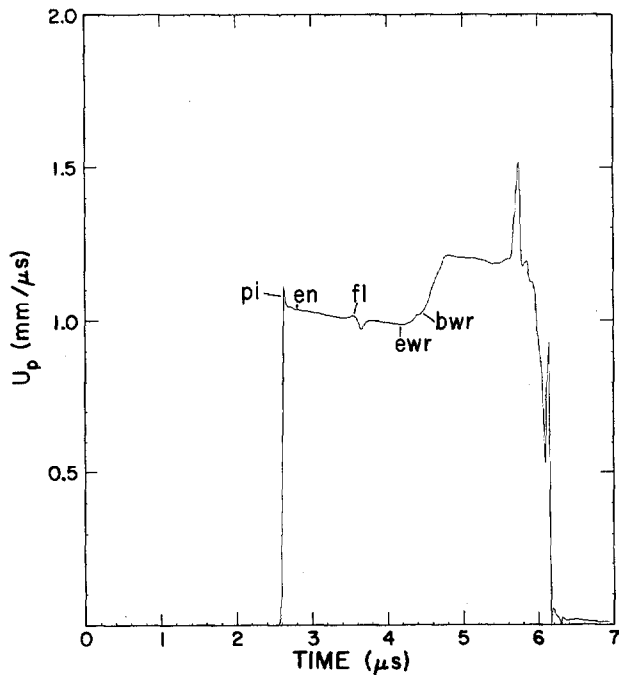

TARGET

Material: Sodium chloride, NaCl (pressed polycrystalline sample)

Experiment type: ASM probe

Experimenters: J. N. Fritz and J. A. Morgan

Shot no.: M 79 **Date:** February 13, 1973

HE SHOT GEOMETRY

P-081 lens/203 mm TNT/5.00 mm sodium chloride/
0.03 mm aluminum//f- 5.01 mm sodium chloride -f/5.02 mm
air//

TRANSDUCER

ASM probe

Coil radius: 28.64 mm **Initial coil spacing:** 10.03 mm

Time: Relative

NOTES

For shielding, a 75-nm aluminum film was deposited on both faces of the sodium chloride sample and was grounded to the aluminum base plate.

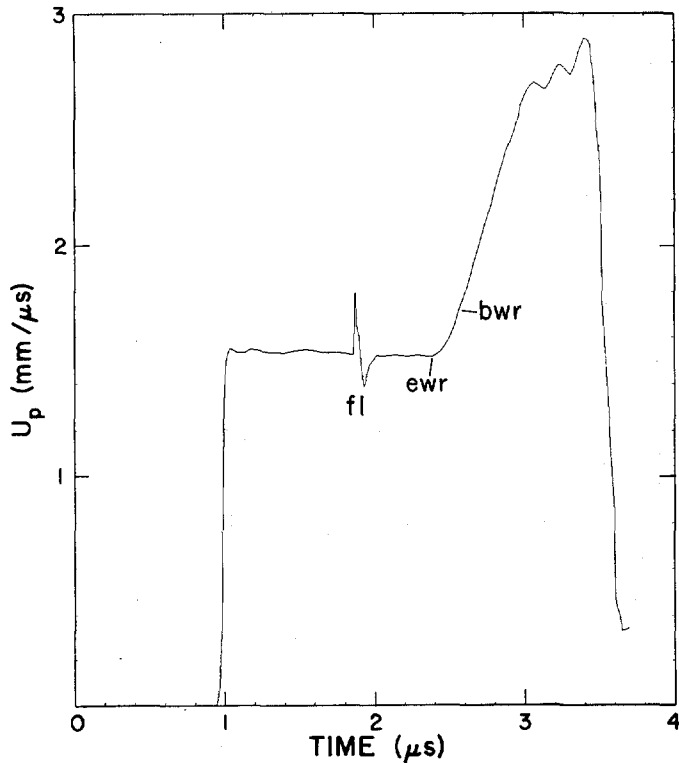

TARGET

Material: Sodium chloride, NaCl (pressed polycrystalline sample)

Experiment type: ASM probe

Experimenters: J. N. Fritz and J. A. Morgan

Shot no.: M 81 **Date:** February 15, 1973

HE SHOT GEOMETRY

P-081 lens/203 mm TNT/12.78 mm 2024 aluminum//
f- 5.00 mm sodium chloride -f/5.01 mm air//

TRANSDUCER

ASM probe

Coil radius: 28.64 mm **Initial coil spacing:** 10.01 mm

Time: Relative

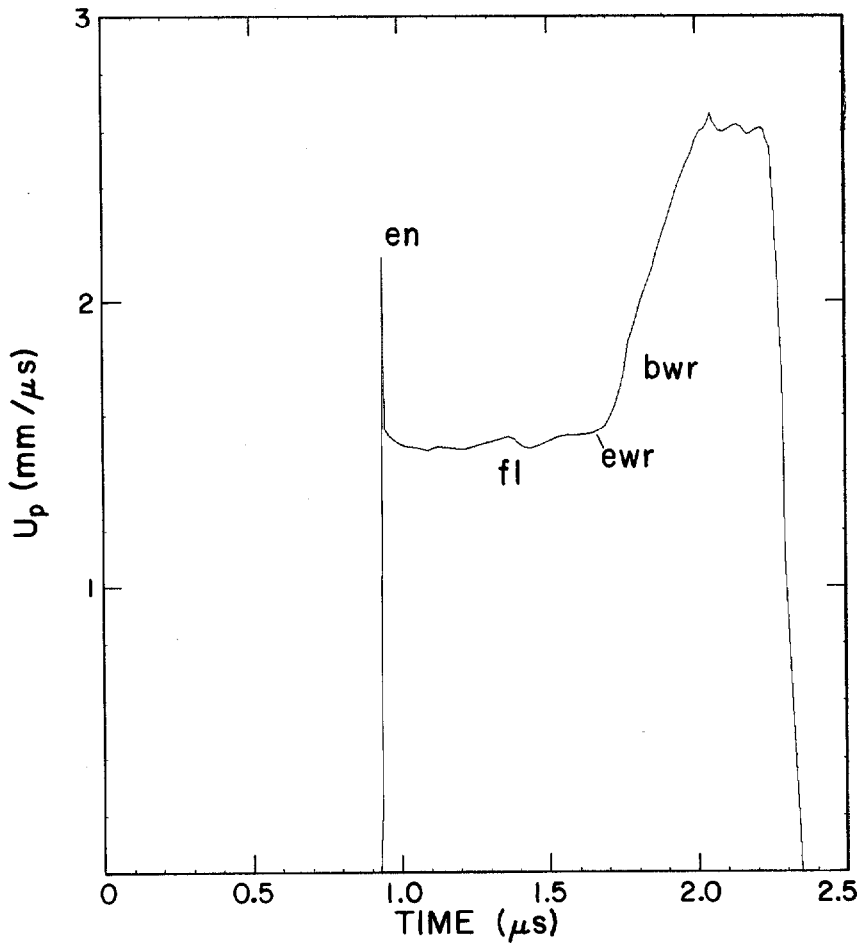

TARGET

Material: Spinel, $MgAl_2O_4$
Experiment type: Free-surface capacitor
Experimenter: J. W. Hopson
Shot no.: 8B572 **Date:** January 21, 1969

HE SHOT GEOMETRY P-081 lens/102 mm TNT/2024 aluminum base plate/
7.75 mm spinel

SHOT COMPONENTS Spinel
Density: 3.27 g/cm^3
 $C_L = 9.02 \text{ mm}/\mu\text{s}$ $C_S = 5.15 \text{ mm}/\mu\text{s}$

TRANSDUCER Free-surface capacitor
Time: Relative

NOTES Shots 8B572, 8B573, and 8B575 are a series with varied impact stress.

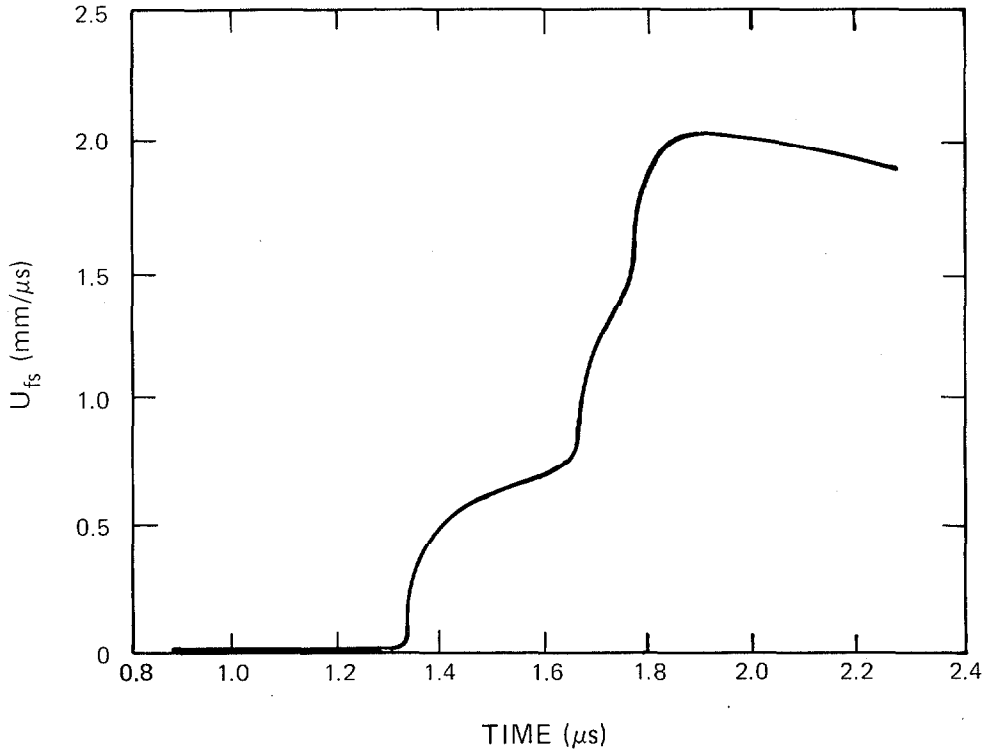

TARGET

Material: Spinel, $MgAl_2O_4$
Experiment type: Free-surface capacitor
Experimenter: J. W. Hopson
Shot no.: 8B573 **Date:** January 21, 1969

HE SHOT GEOMETRY

102 mm Comp B/2024 aluminum base plate/6.47 mm spinel

SHOT COMPONENTS

Spinel
Density: 3.27 g/cm^3
 $C_L = 9.02 \text{ mm}/\mu\text{s}$ $C_S = 5.15 \text{ mm}/\mu\text{s}$

TRANSDUCER

Free-surface capacitor
Time: Relative

NOTES

Shots 8B572, 8B573, and 8B575 are a series with varied impact stress.

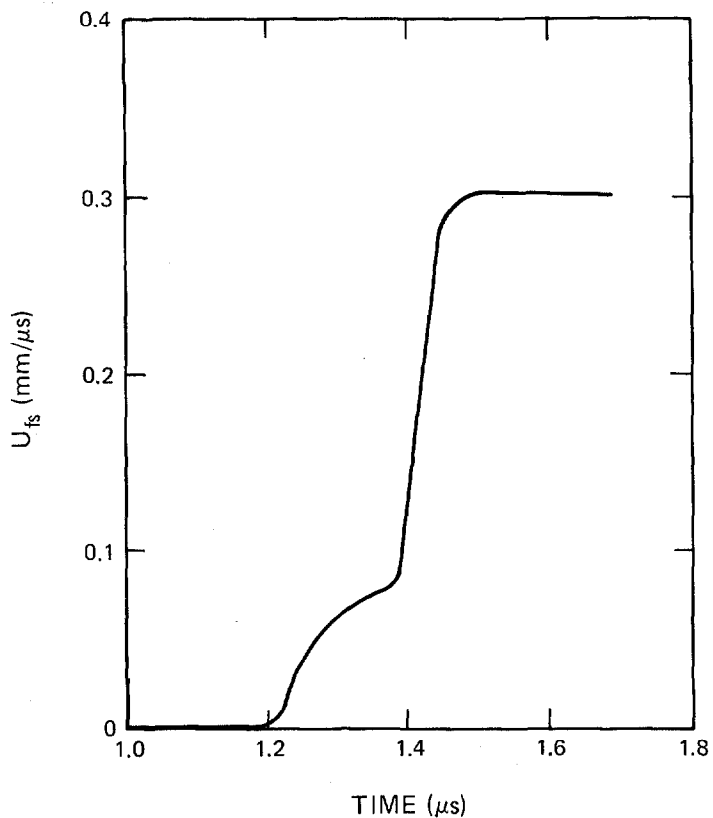

TARGET

Material: Spinel, $MgAl_2O_4$
Experiment type: Free-surface capacitor
Experimenter: J. W. Hopson
Shot no.: 8B575 Date: January 21, 1969

HE SHOT GEOMETRY 102 mm baratol/2024 aluminum base plate/7.75 mm spinel

SHOT COMPONENTS

Spinel
Density: 3.27 g/cm^3
 $C_L = 9.02 \text{ mm}/\mu\text{s}$ $C_S = 5.15 \text{ mm}/\mu\text{s}$

TRANSDUCER

Free-surface capacitor
Time: Relative

NOTES

Shots 8B572, 8B573, and 8B575 are a series with varied impact stress.

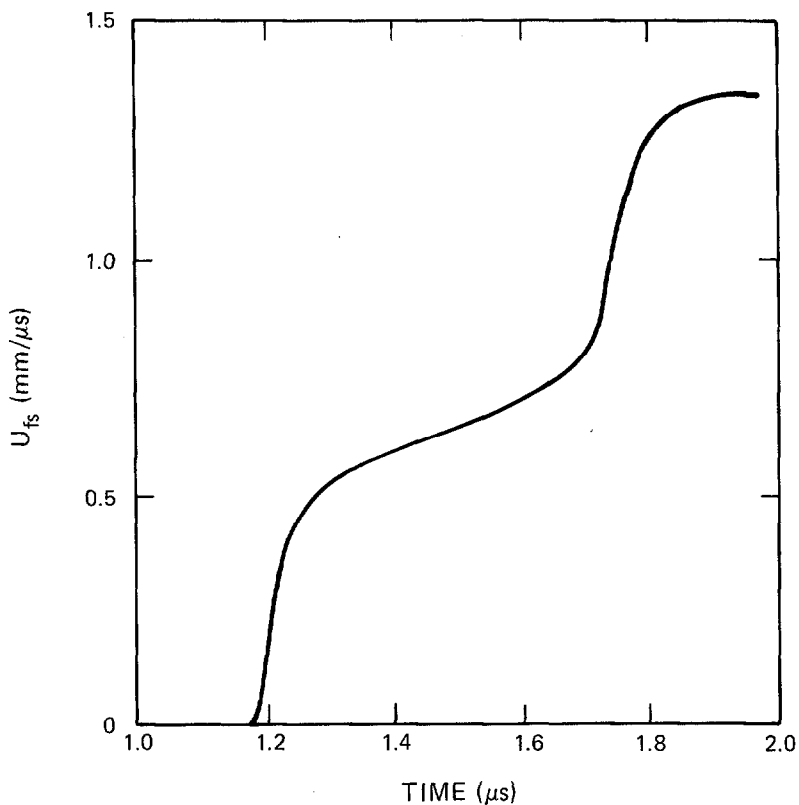

TARGET

Material: Tantalum carbide, TaC_{0.50}
Experiment type: Free-surface capacitor
Experimenter: J. W. Hopson
Shot no.: 8B624 **Date:** May 14, 1969

HE SHOT GEOMETRY

P-080 lens/102 mm baratol/2024 aluminum base plate/
5.31 mm tantalum carbide

SHOT COMPONENTS

Tantalum carbide
Density: 15.60 g/cm³
C_L = 4.94 mm/μs **C_S** = 2.63 mm/μs

TRANSDUCER

Free-surface capacitor
Time: Relative

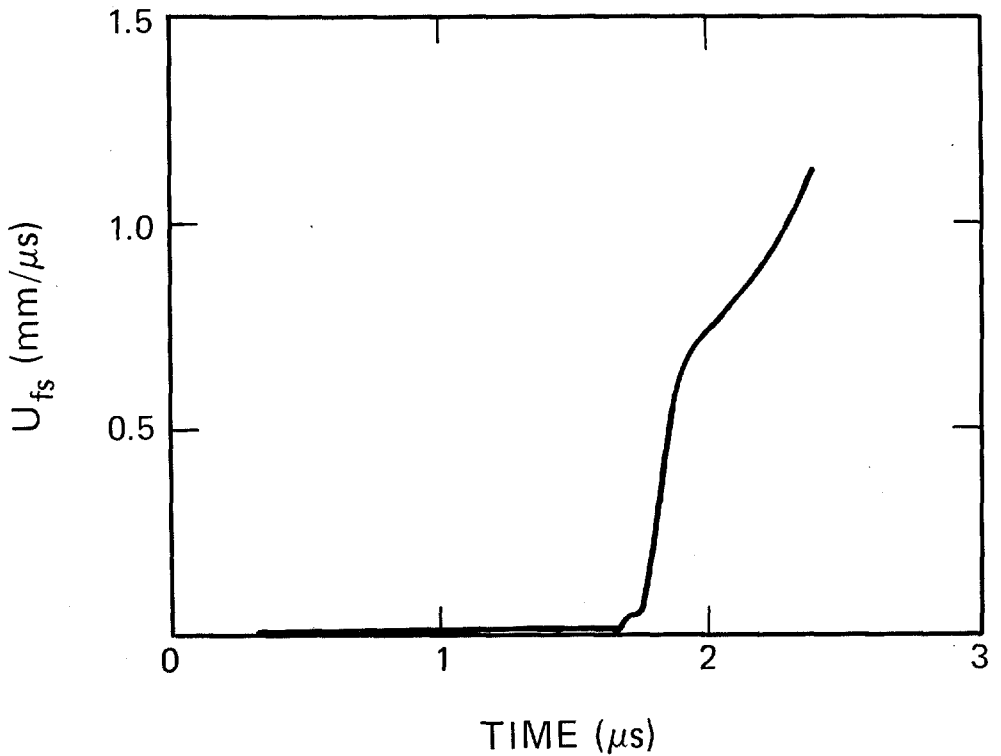

TARGET **Material:** Tantalum carbide carbon, TaCC-90, 10% porosity
Experiment type: Free-surface capacitor
Experimenter: J. W. Hopson
Shot no.: 56-70-36 **Date:** April 3, 1970
Thickness: 6.34 mm
Density: 3.00 g/cm³
C_L = 1.80 mm/μs

IMPACTOR 3.16 mm tantalum carbide backed with 3.04 mm steel, mounted on aluminum alloy projectile

TRANSDUCER Free-surface capacitor
Time: Relative

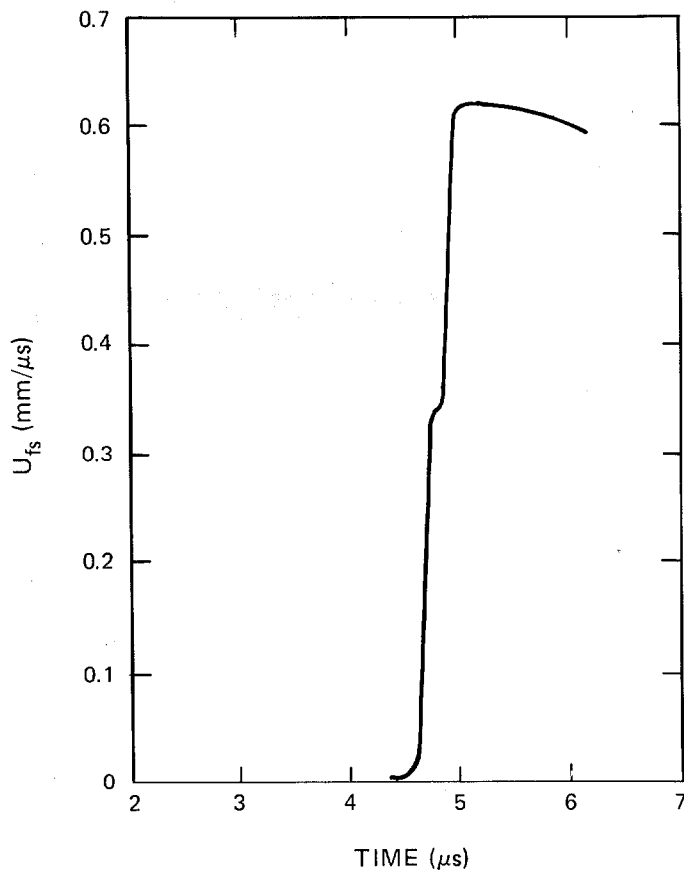

TARGET

Material: Titanium boride, TiB_2 (Union Carbide)
Experiment type: Free-surface capacitor
Experimenter: J. W. Hopson
Shot no.: 8B604 Date: February 25, 1969

HE SHOT GEOMETRY

P-080 lens/102 mm baratol/2024 aluminum base plate/
9.53 mm titanium boride

SHOT COMPONENTS

Titanium boride
Density: 4.50 g/cm^3
 $C_L = 10.94 \text{ mm}/\mu\text{s}$ $C_S = 6.85 \text{ mm}/\mu\text{s}$

TRANSDUCER

Free-surface capacitor
Time: Relative

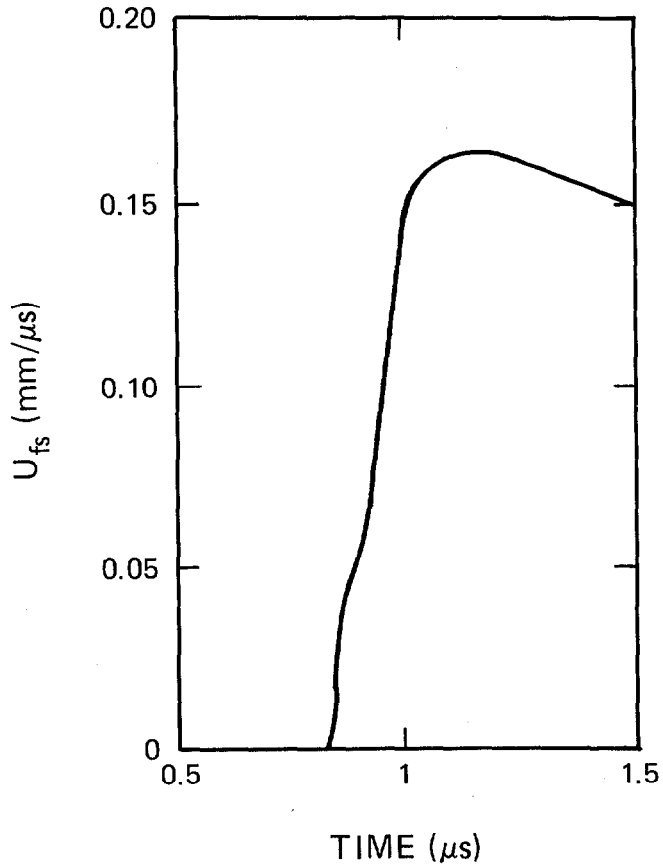

TARGET

Material: Titanium boride, TiB_2
Experiment type: Free-surface capacitor
Experimenter: J. W. Hopson
Reference: R. G. McQueen, S. P. Marsh, J. W. Taylor, J. N. Fritz, and W. J. Carter (1970)
Shot no.: 8B612 **Date:** March 14, 1969

HE SHOT GEOMETRY P-080 lens/102 mm baratol/2024 aluminum base plate/
10.16 mm titanium boride

SHOT COMPONENTS Titanium boride
Density: 4.30 g/cm^3
 $C_L = 10.97 \text{ mm}/\mu\text{s}$ $C_S = 7.30 \text{ mm}/\mu\text{s}$

TRANSDUCER Free-surface capacitor
Time: Relative

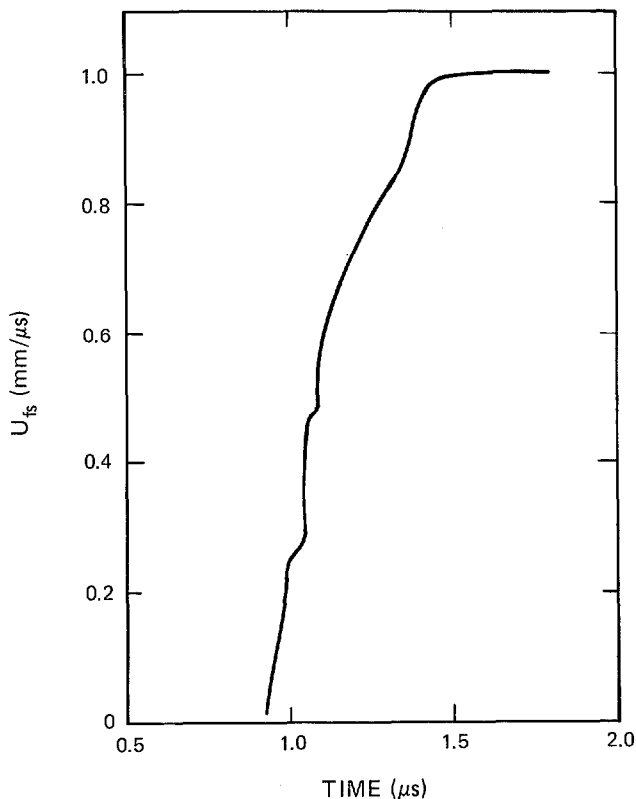

TARGET

Material: Tungsten carbide, WC (Metalwerke Plansee, Grade 850)
Experiment type: Free-surface capacitor
Experimenter: J. W. Taylor
Reference: R. G. McQueen, S. P. Marsh, J. W. Taylor, J. N. Fritz,
and W. J. Carter (1970)
Shot no.: 56-63-277 Date: October 10, 1963
Thickness: 12.7 mm Diameter: 38.1 mm
Density: 15.00 g/cm³

IMPACTOR

Tungsten carbide (Metalwerke Plansee, Grade 850), 6.35 mm thick,
backed with low-density polyurethane foam, mounted on 51-mm-diam
aluminum alloy projectile
Impact velocity: 0.300 mm/ μ s

TRANSDUCER

Free-surface capacitor
Time: Relative

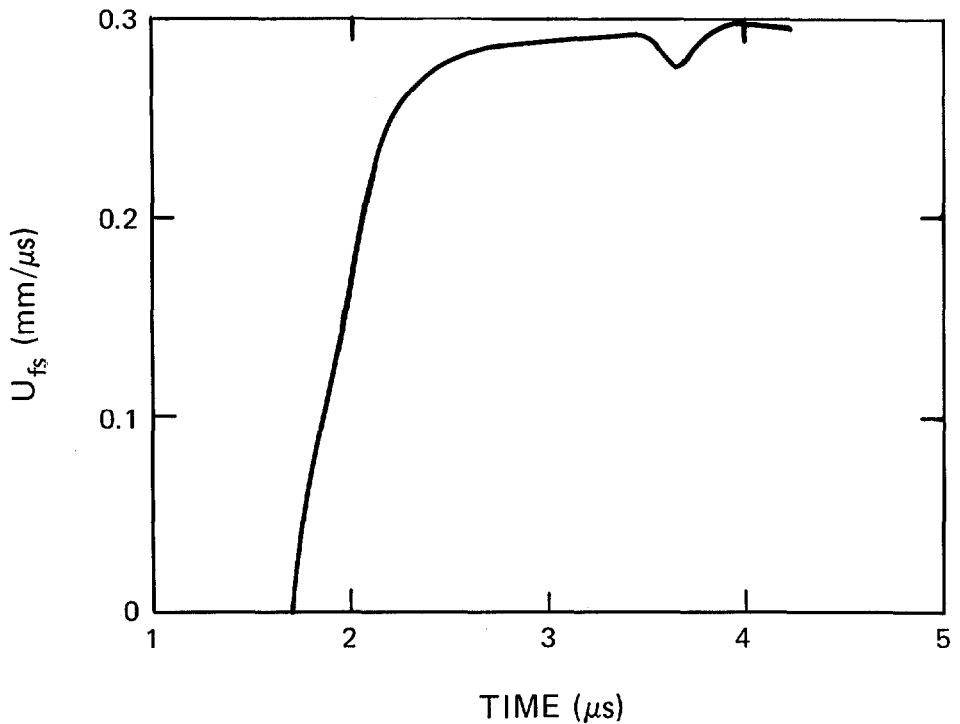

TARGET

Material: Tungsten carbide, WC (Kennametal, Grade K8)
Experiment type: Free-surface capacitor
Experimenter: J. W. Hopson
Shot no.: 80305 **Date:** August 8, 1968

HE SHOT GEOMETRY

P-080 lens/102 mm baratol/2024 aluminum base plate/
13.04 mm tungsten carbide

SHOT COMPONENTS

Tungsten carbide
Density: 15.01 g/cm³
 $C_L = 6.75$ mm/ μ s $C_s = 3.95$ mm/ μ s

TRANSDUCER

Free-surface capacitor
Time: Relative

NOTES

Shots 80305, 80306, and 80308 are a series with varied impact stress.

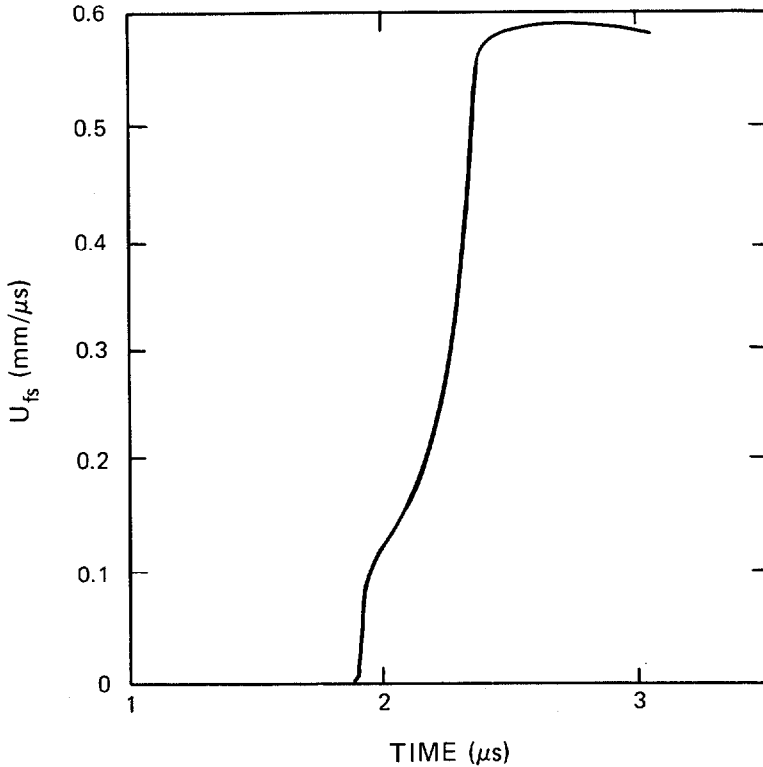

TARGET Material: Tungsten carbide, WC (Kennametal, Grade K-8)
Experiment type: Free-surface capacitor
Experimenter: J. W. Hopson
Shot no.: 80306 Date: August 8, 1968

HE SHOT GEOMETRY P-080 lens/102 mm TNT/2024 aluminum base plate/
13.04 mm tungsten carbide

SHOT COMPONENTS Tungsten carbide
Density: 15.01 g/cm³
 $C_L = 6.75$ mm/ μ s $C_S = 3.95$ mm/ μ s

TRANSDUCER Free-surface capacitor
Time: Relative

NOTES Shots 80305, 80306, and 80308 are a series with varied impact stress.

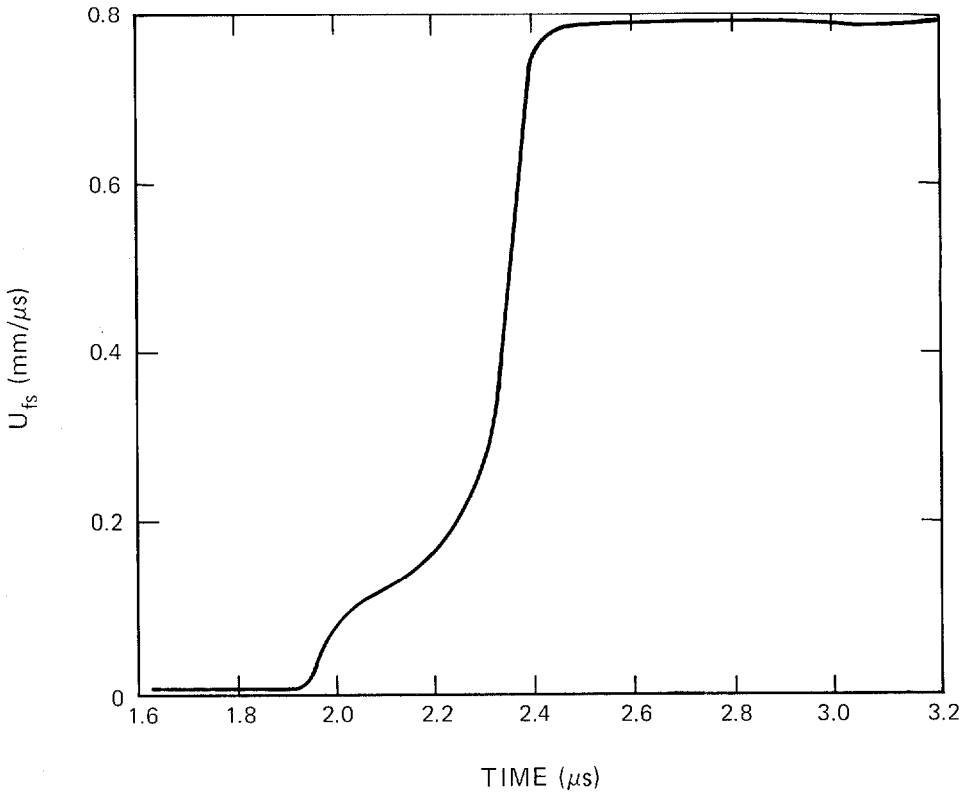

TARGET

Material: Tungsten carbide, WC (Kennametal, Grade K8)
Experiment type: Free-surface capacitor
Experimenter: J. W. Hopson
Shot no.: 80308 **Date:** October 9, 1968

HE SHOT GEOMETRY

P-120 lens/102 mm Comp B/1.6 mm air/5.0 mm stainless steel driver plate/50 mm free run/6.35 mm 2024 aluminum base plate/13.0 mm tungsten carbide

SHOT COMPONENTS

Tungsten carbide
Density: 15.01 g/cm³
 $C_L = 6.75 \text{ mm}/\mu\text{s}$ $C_S = 3.95 \text{ mm}/\mu\text{s}$

TRANSDUCER

Free-surface capacitor
Time: Relative

NOTES

Shots 80305, 80306, and 80308 are a series with varied impact stress.

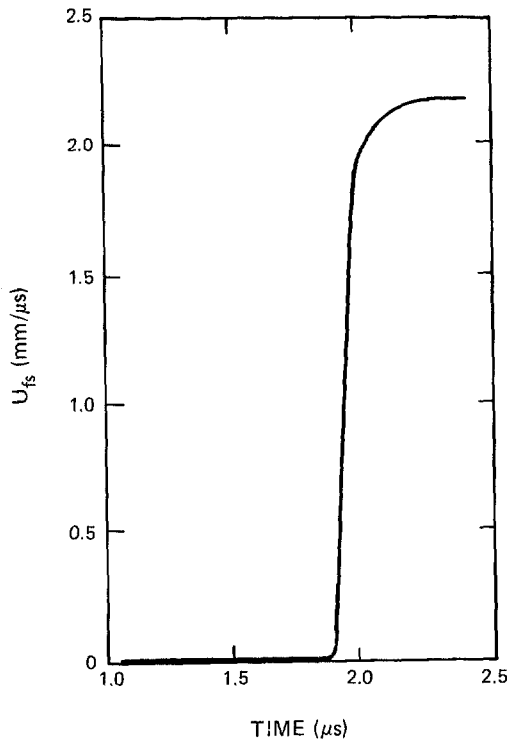

TARGET

Material: Tungsten carbide, WC (2A-S)
Experiment type: Free-surface capacitor
Experimenter: J. W. Hopson
Shot no.: 8B551 **Date:** December 10, 1968

HE SHOT GEOMETRY

102 mm baraton/1.31 mm 2024 aluminum base plate/
9.14 mm tungsten carbide

SHOT COMPONENTS

Tungsten carbide
Density: 14.75 g/cm³
 $C_L = 6.72$ mm/ μ s

TRANSDUCER

Free-surface capacitor
Time: Relative

NOTES

Shots 8B551 and 8B553 are a series with varied impact stress.

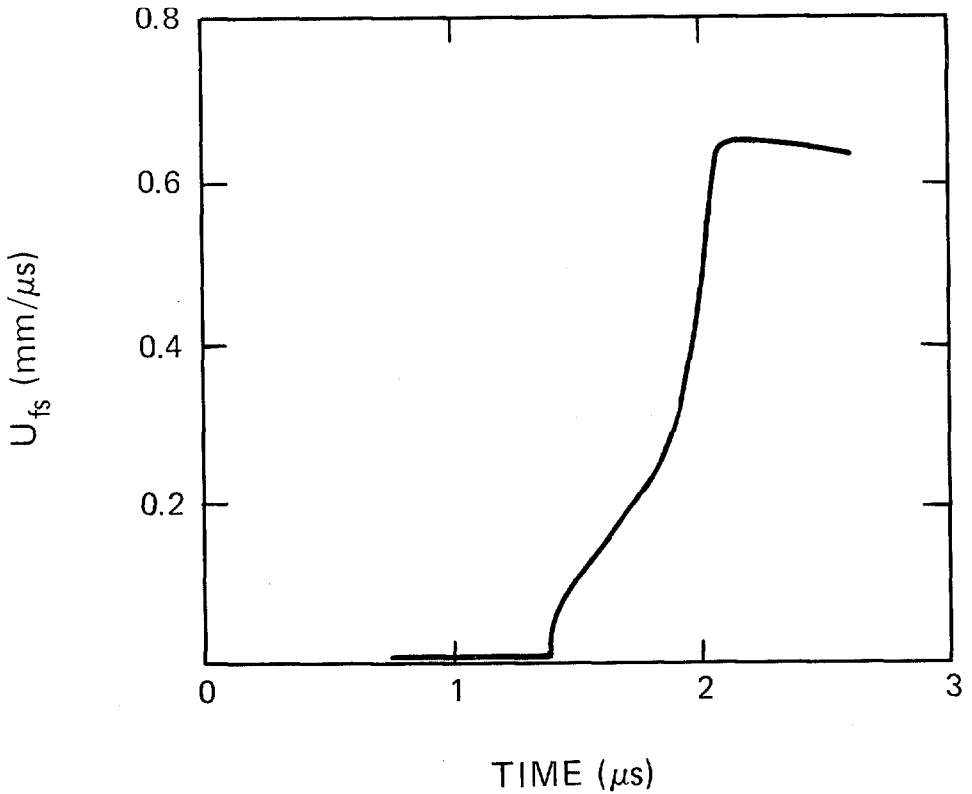

TARGET

Material: Tungsten carbide, WC (2A-S)
Experiment type: Free-surface capacitor
Experimenter: J. W. Hopson
Shot no.: 8B553 **Date:** December 10, 1968

HE SHOT GEOMETRY

P-080 lens/102 mm TNT/2024 aluminum base plate/
9.14 mm tungsten carbide

SHOT COMPONENTS

Tungsten carbide
Density: 14.75 g/cm³
 $C_L = 6.72$ mm/ μ s

TRANSDUCER

Free-surface capacitor
Time: Relative

NOTES

Shots 8B551 and 8B553 are a series with varied impact stress.

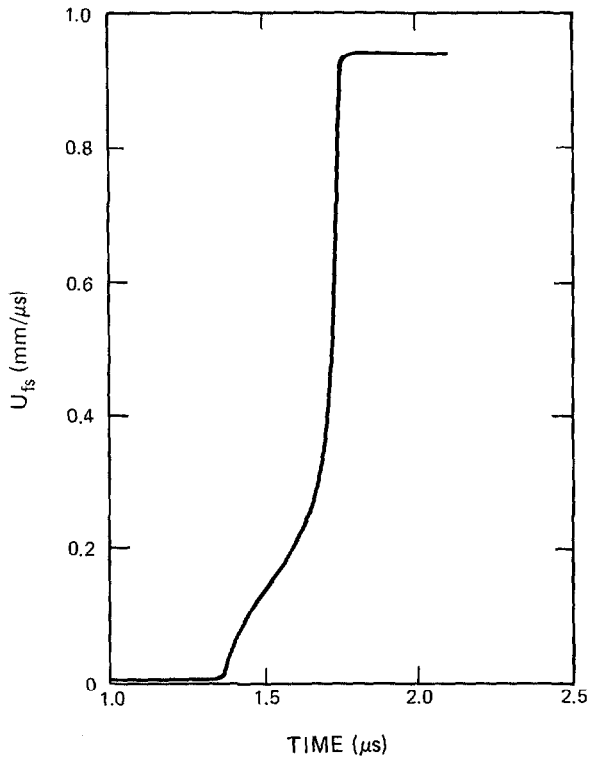

TARGET

Material: Zirconium boride, ZrB_2
Experiment type: Free-surface capacitor
Experimenter: J. W. Hopson
Shot no.: 8ZB01 **Date:** August 16, 1968
Thickness: 9.53 mm

HE SHOT GEOMETRY

P-080 lens/102 mm baratol/2024 aluminum base plate

SHOT COMPONENT

Zirconium boride
Density: 5.67 g/cm^3
 $C_L = 9.28 \text{ mm}/\mu\text{s}$ $C_S = 5.91 \text{ mm}/\mu\text{s}$

TRANSDUCER

Free-surface capacitor
Time: Relative

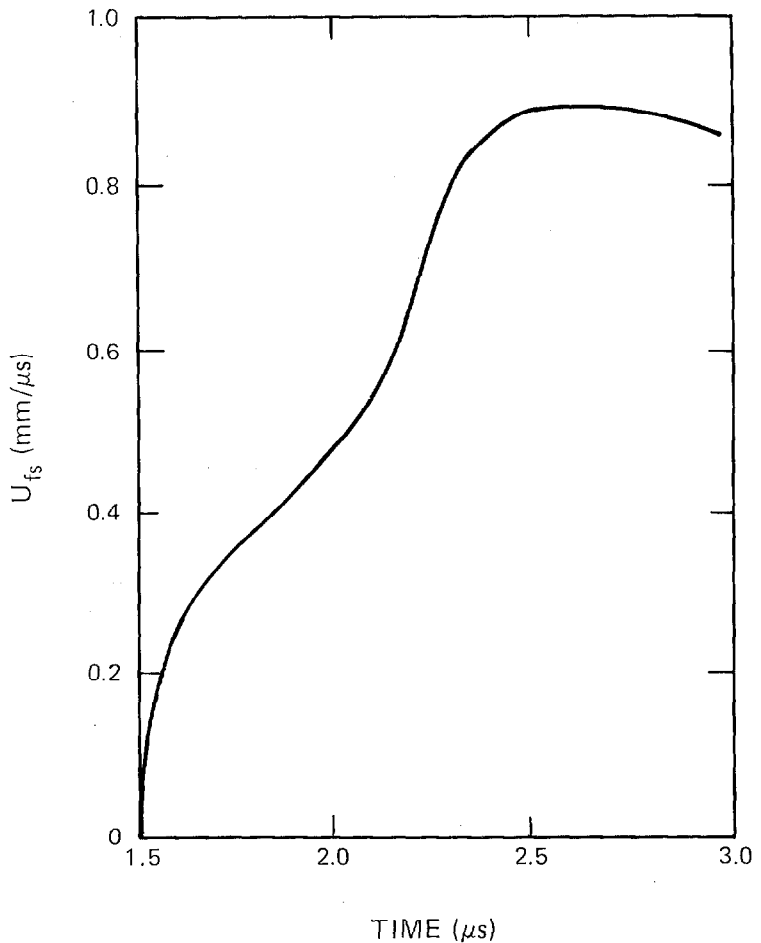

ROCKS AND MIXTURES OF MINERALS

TARGET **Material:** Corundum mixture—85.2 wt% aluminum oxide, Al_2O_3 /9.7 wt% silicon dioxide, SiO_2 /2.7 wt% magnesium oxide, MgO /2.4 wt% calcium oxide-barium oxide, CaO-BaO
Experiment type: ASM probe
Experimenters: J. N. Fritz and J. A. Morgan
Shot no.: M 54 **Date:** December 27, 1971

HE SHOT GEOMETRY P-081 lens/102 mm Comp B/6.344 mm corundum mixture/
0.03 mm aluminum//6.334 mm corundum mixture -f/
5.00 mm air//

SHOT COMPONENTS Corundum mixture
Density: 3.389 g/cm^3
 $C_L = 8.94 \text{ mm}/\mu\text{s}$ $C_S = 5.25 \text{ mm}/\mu\text{s}$
Comp B
Density: 1.726 g/cm^3
 $C_L = 3.12 \text{ mm}/\mu\text{s}$ $C_S = 1.71 \text{ mm}/\mu\text{s}$

TRANSDUCER ASM probe
Coil radius: 28.64 mm **Initial coil spacing:** 11.334 mm

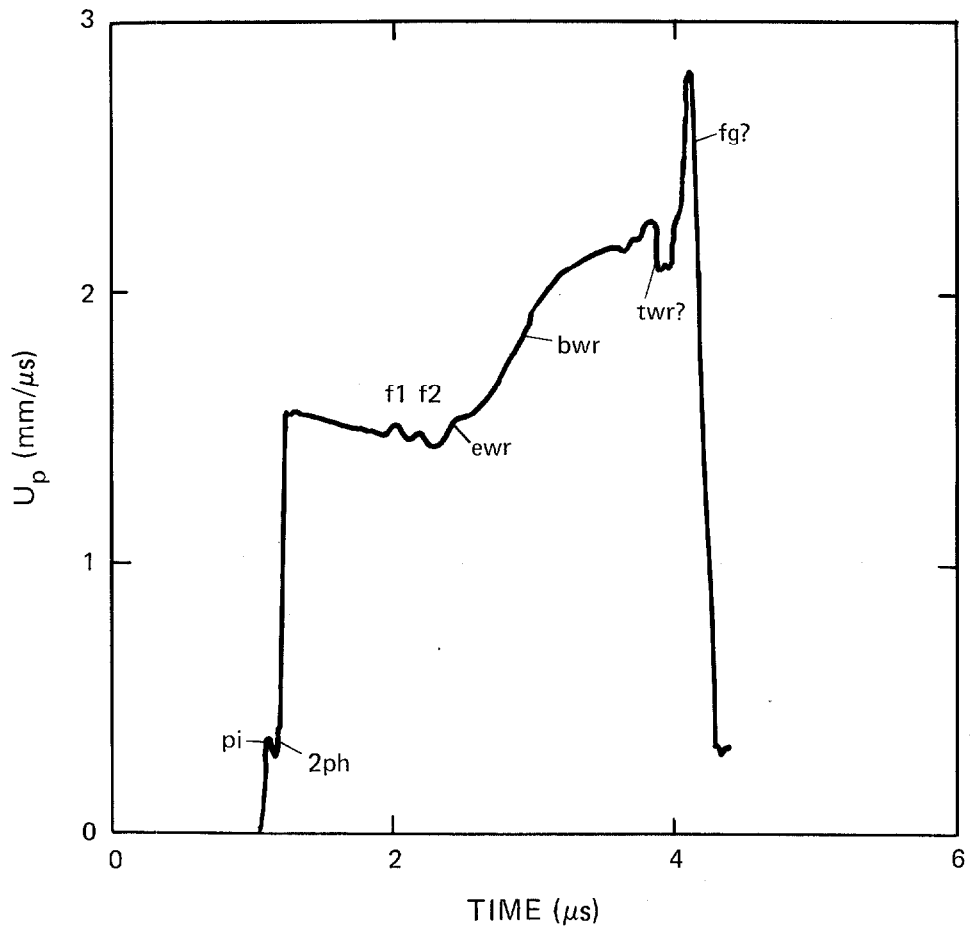

TARGET

Material: Devonian gas shale (shock direction normal to bedding plane), Lincoln County, West Virginia
Experiment type: Embedded Manganin gage
Experimenter: Bart Olinger
Shot no.: 56-77-47 **Date:** April 11, 1977
Diameter: 40.0 mm
Density: 2.44 g/cm³
 $C_L = 3.36$ mm/ μ s

IMPACTOR

OFHC copper, 5.30 mm thick, backed with low-density polyurethane foam, mounted on 51-mm-diam aluminum alloy projectile
Impact velocity: 0.435 mm/ μ s

TRANSDUCER

Two-terminal, 50- Ω Manganin gage
Locations from impact surface: 2.21 mm and 6.82 mm
Heat treatment: Annealed
Encapsulation: None
Calibration: J. W. Hopson and J. W. Taylor calibration formula for Manganin gages
 $\sigma = a_1 x + b_1 x^2 + c_1 x^3$ for $x < 0.1$,
 $\sigma = a_2 + b_2 x + c_2 x^2$ for $x > 0.1$,
where $x = \Delta R/R$.
 $a_1 = 521.32$ $b_1 = -1614.86$ $c_1 = 7648.72$
 $a_2 = 6.5950$ $b_2 = 370.37$ $c_2 = 0.00$
Time: Relative

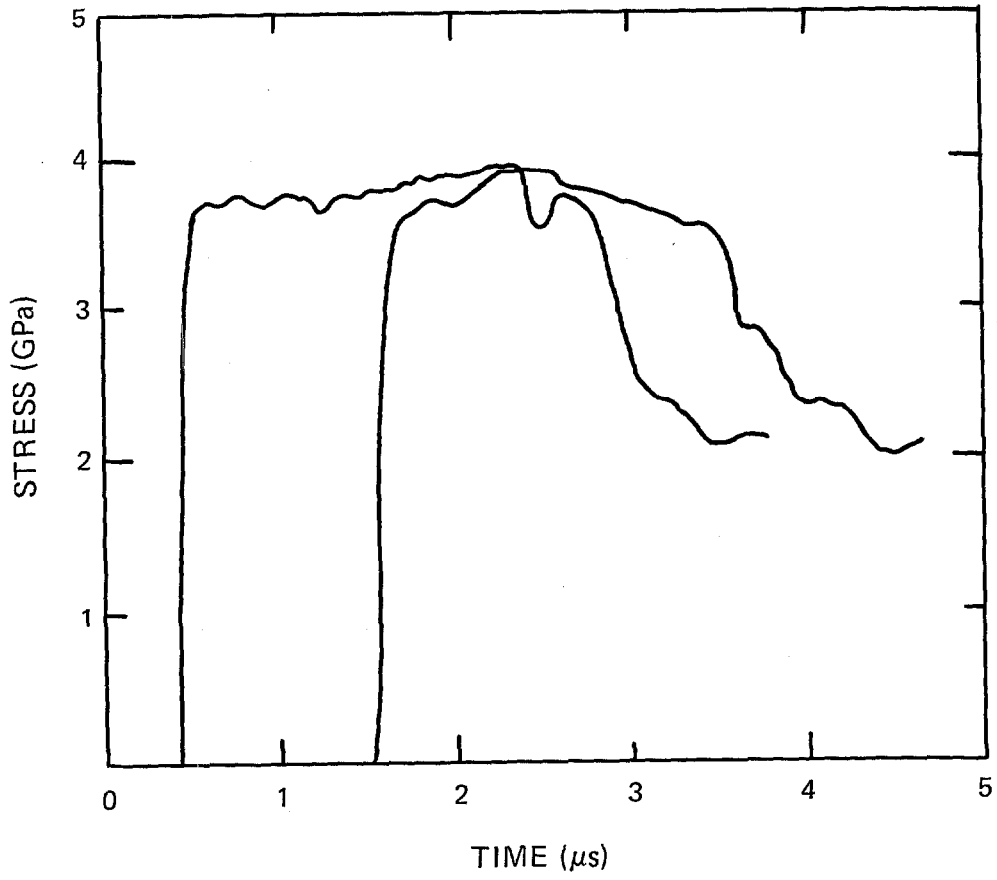

TARGET

Material: Devonian gas shale (shock direction normal to bedding plane), Lincoln County, West Virginia

Experiment type: Embedded Manganin gage

Experimenter: Bart Olinger

Shot no.: 56-77-48 **Date:** April 11, 1977

Diameter: 40.0 mm

Density: 2.44 g/cm³

$C_L = 3.33$ mm/ μ s

IMPACTOR

6061 aluminum, 5.30 mm thick, backed with low-density polyurethane foam, mounted on 51-mm-diam aluminum alloy projectile

Impact velocity: 0.095 mm/ μ s

TRANSDUCER

Two-terminal, 50- Ω Manganin gage

Locations from impact surface: 2.24 mm, 6.82 mm, and 11.40 mm

Heat treatment: Annealed

Encapsulation: None

Calibration: J. W. Hopson and J. W. Taylor calibration formula for Manganin gages

$\sigma = a_1 x + b_1 x^2 + c_1 x^3$ for $x < 0.1$,

$\sigma = a_2 + b_2 x + c_2 x^2$ for $x > 0.1$,

where $x = \Delta R/R$.

$a_1 = 521.32$ $b_1 = -1614.86$ $c_1 = 7648.72$

$a_2 = 6.5950$ $b_2 = 370.37$ $c_2 = 0.00$

Time: Relative

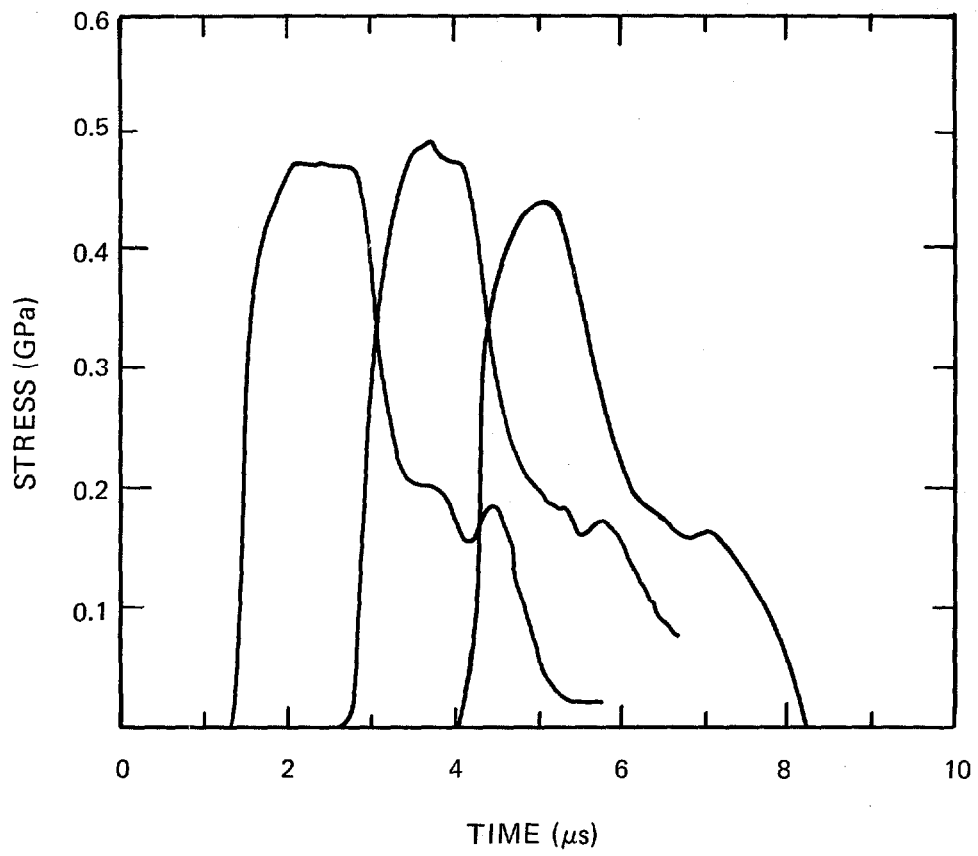

TARGET **Material:** Devonian gas shale (shock direction parallel to bedding plane), Lincoln County, West Virginia
Experiment type: Embedded Manganin gage
Experimenter: Bart Olinger
Shot no.: 56-77-49 **Date:** April 11, 1977
Diameter: 40.0 mm
Density: 2.43 g/cm³
C_L = 4.70 mm/μs

IMPACTOR OFHC copper, 5.20 mm thick, backed with low-density polyurethane foam, mounted on 51-mm-diam aluminum alloy projectile
Impact velocity: 0.350 mm/μs

TRANSDUCER Two-terminal, 50-Ω Manganin gage
Locations from impact surface: 2.18 mm, 6.73 mm, and 11.27 mm
Heat treatment: Annealed
Encapsulation: None
Calibration: J. W. Hopson and J. W. Taylor calibration formula for Manganin gages
 $\sigma = a_1 x + b_1 x^2 + c_1 x^3$ for $x < 0.1$,
 $\sigma = a_2 + b_2 x + c_2 x^2$ for $x > 0.1$,
where $x = \Delta R/R$.
a₁ = 521.32 **b₁** = -1614.86 **c₁** = 7648.72
a₂ = 6.5950 **b₂** = 370.37 **c₂** = 0.00
Time: Relative

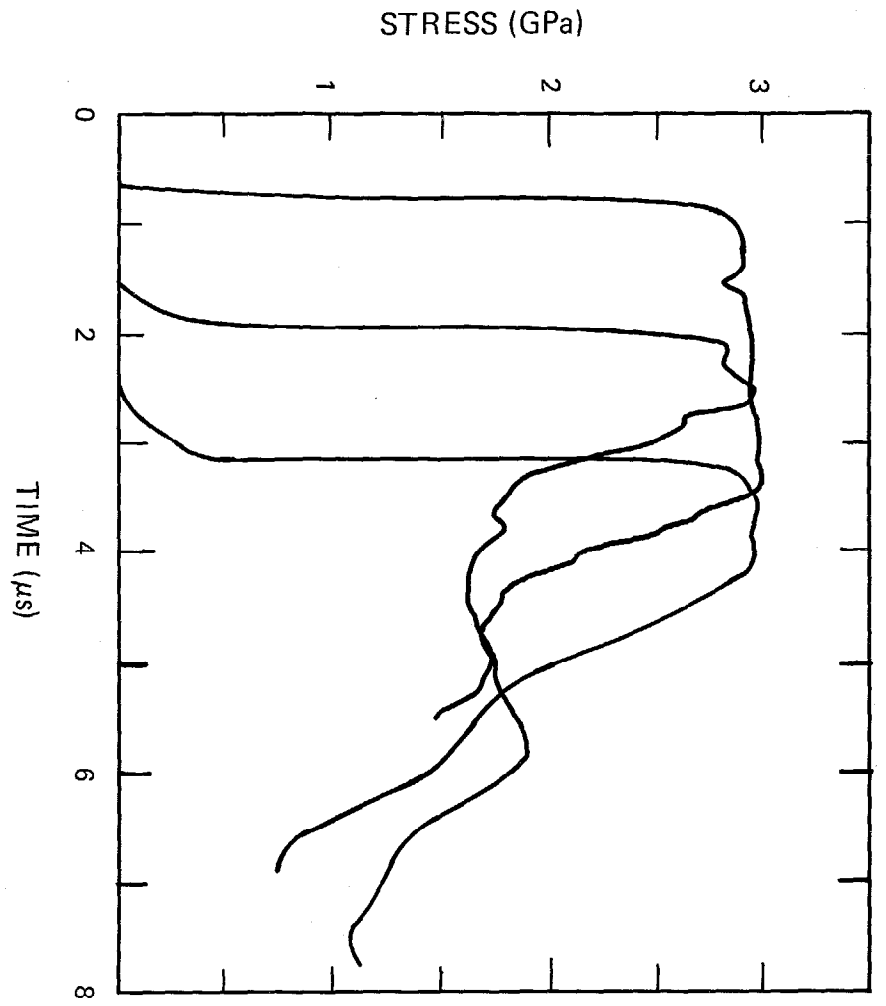

TARGET

Material: Devonian gas shale (shock direction parallel to bedding plane), Lincoln County, West Virginia

Experiment type: Embedded Manganin gage

Experimenter: Bart Olinger

Shot no.: 56-77-50 **Date:** April 13, 1977

Diameter: 40.0 mm

Density: 2.72 g/cm³

$C_L = 5.01$ mm/ μ s

IMPACTOR

OFHC copper, 5.20 mm thick, backed with low-density polyurethane foam, mounted on 51-mm-diam aluminum alloy projectile

Impact velocity: 0.290 mm/ μ s

TRANSDUCER

Two-terminal, 50- Ω Manganin gage

Locations from impact surface: 2.04 mm, 6.49 mm, and 10.94 mm

Heat treatment: Annealed

Encapsulation: None

Calibration: J. W. Hopson and J. W. Taylor calibration formula for Manganin gages

$\sigma = a_1 x + b_1 x^2 + c_1 x^3$ for $x < 0.1$,

$\sigma = a_2 + b_2 x + c_2 x^2$ for $x > 0.1$,

where $x = \Delta R/R$.

$a_1 = 521.32$ $b_1 = -1614.86$ $c_1 = 7648.72$

$a_2 = 6.5950$ $b_2 = 370.37$ $c_2 = 0.00$

Time: Relative

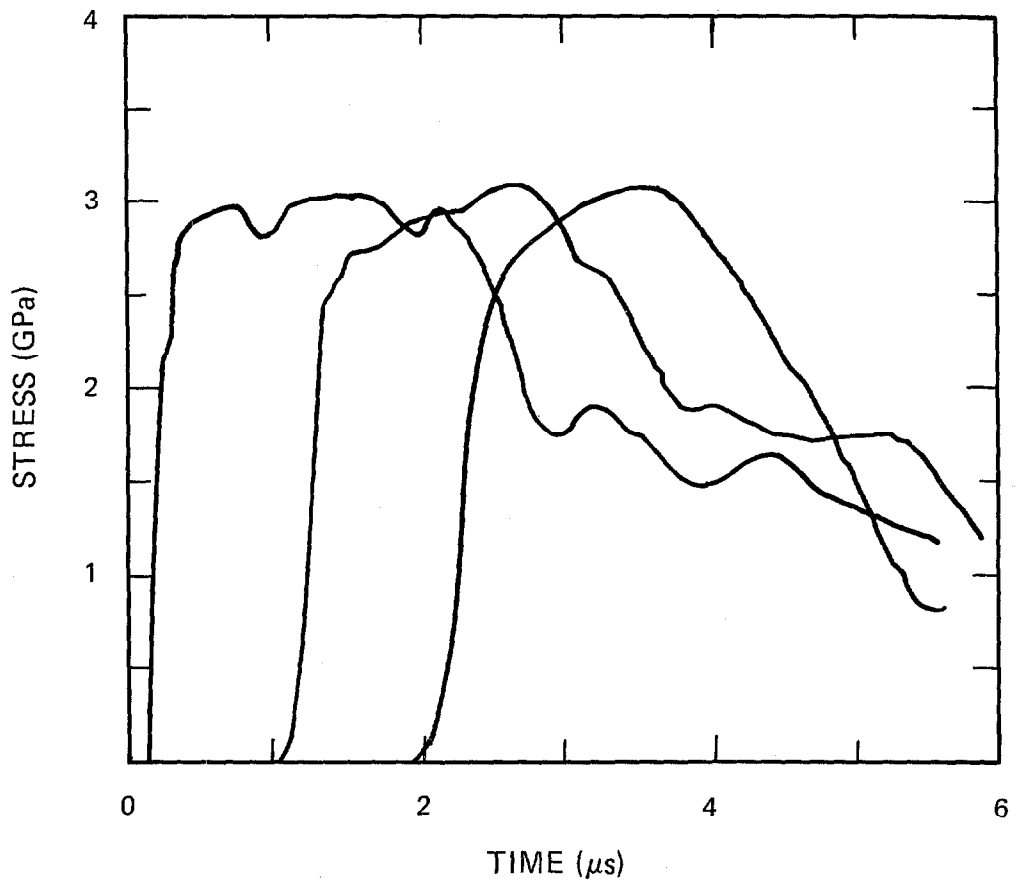

TARGET **Material:** Devonian gas shale (shock direction parallel to bedding plane), Lincoln County, West Virginia
Experiment type: Embedded Manganin gage
Experimenter: Bart Olinger
Shot no.: 56-77-51 **Date:** April 15, 1977
Diameter: 40.0 mm
Density: 2.72 g/cm³
C_L = 5.32 mm/μs

IMPACTOR 6061 aluminum, 5.20 mm thick, backed with low-density polyurethane foam, mounted on 51-mm-diam aluminum alloy projectile
Impact velocity: 0.065 mm/μs

TRANSDUCER Two-terminal, 50-Ω Manganin gage
Locations from impact surface: 1.94 mm, 6.40 mm, and 10.83 mm
Heat treatment: Annealed
Encapsulation: None
Calibration: J. W. Hopson and J. W. Taylor calibration formula for Manganin gages
 $\sigma = a_1 x + b_1 x^2 + c_1 x^3$ for $x < 0.1$,
 $\sigma = a_2 + b_2 x + c_2 x^2$ for $x > 0.1$,
where $x = \Delta R/R$.
 $a_1 = 521.32$ $b_1 = -1614.86$ $c_1 = 7648.72$
 $a_2 = 6.5950$ $b_2 = 370.37$ $c_2 = 0.00$
Time: Relative

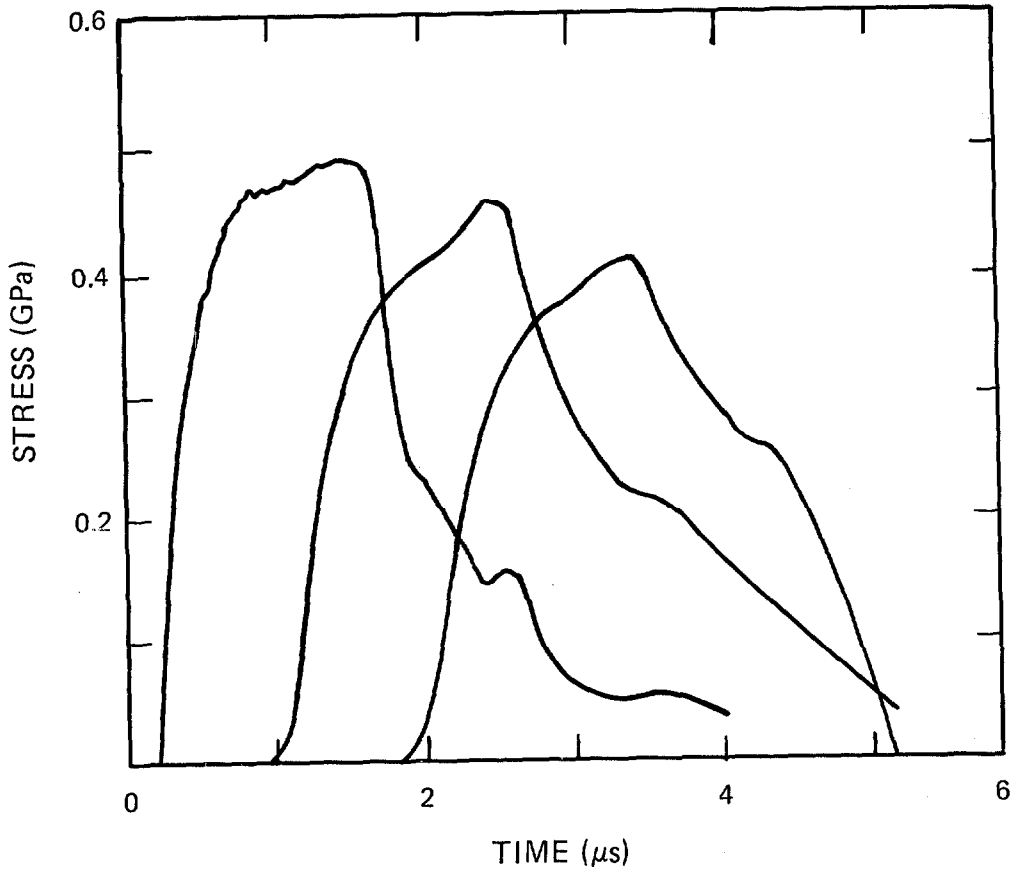

TARGET

Material: Devonian gas shale (shock direction normal to bedding plane), Lincoln County, West Virginia

Experiment type: Embedded Manganin gage

Experimenter: Bart Olinger

Shot no.: 56-77-52 **Date:** April 13, 1977

Diameter: 40.0 mm

Density: 2.71 g/cm³

$C_L = 3.97$ mm/ μ s

IMPACTOR

6061 aluminum, 5.10 mm thick, backed with low-density polyurethane foam, mounted on 51-mm-diam aluminum alloy projectile

Impact velocity: 0.080 mm/ μ s

TRANSDUCER

Two-terminal, 50- Ω Manganin gage

Locations from impact surface: 2.06 mm, 6.46 mm, and 10.10 mm

Heat treatment: Annealed

Encapsulation: None

Calibration: J. W. Hopson and J. W. Taylor calibration formula for Manganin gages

$\sigma = a_1 x + b_1 x^2 + c_1 x^3$ for $x < 0.1$,

$\sigma = a_2 + b_2 x + c_2 x^2$ for $x > 0.1$,

where $x = \Delta R/R$.

$a_1 = 521.32$ $b_1 = -1614.86$ $c_1 = 7648.72$

$a_2 = 6.5950$ $b_2 = 370.37$ $c_2 = 0.00$

Time: Relative

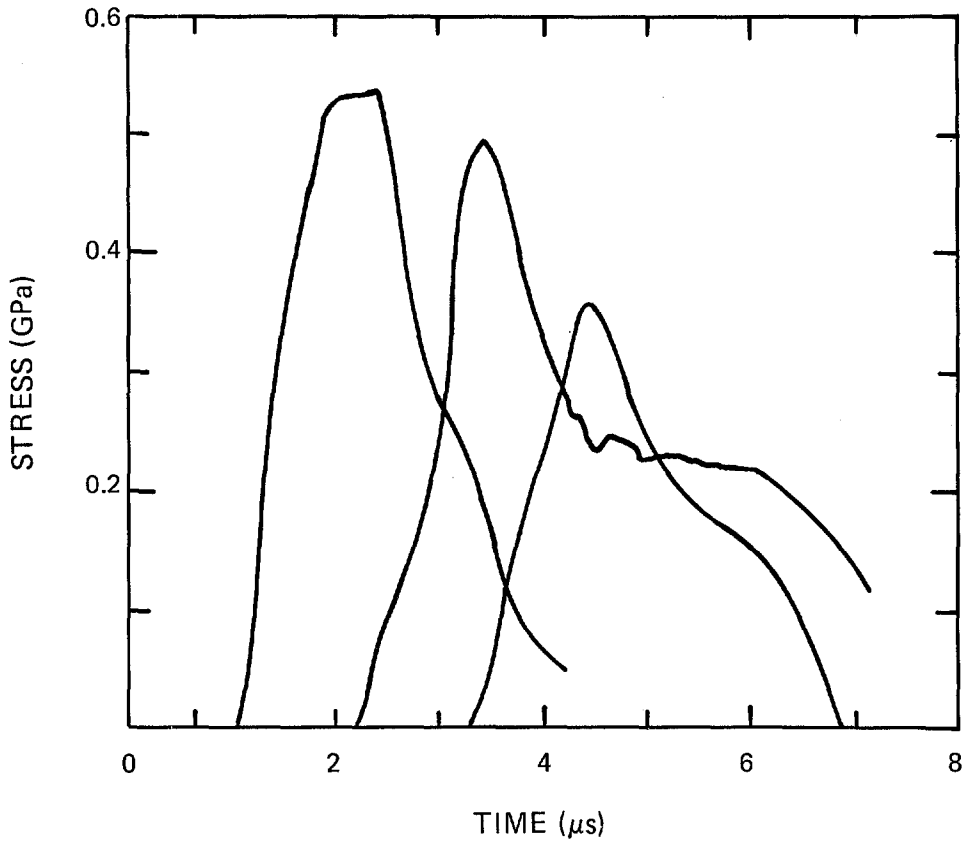

TARGET

Material: Devonian gas shale (shock direction parallel to bedding plane), Lincoln County, West Virginia

Experiment type: Embedded Manganin gage

Experimenter: Bart Olinger

Shot no.: 56-77-53 **Date:** April 19, 1977

Diameter: 40.0 mm

Density: 2.40 g/cm³

C_L = 4.57 mm/μs

IMPACTOR

6061 aluminum, 5.10 mm thick, backed with low-density polyurethane foam, mounted on 51-mm-diam aluminum

alloy projectile

Impact velocity: 0.075 mm/μs

TRANSDUCER

Two-terminal, 50-Ω Manganin gage

Locations from impact surface: 2.21 mm, 6.75 mm, and 11.26 mm

Heat treatment: Annealed

Encapsulation: None

Calibration: J. W. Hopson and J. W. Taylor calibration formula for Manganin gages

$\sigma = a_1 x + b_1 x^2 + c_1 x^3$ for $x < 0.1$,

$\sigma = a_2 + b_2 x + c_2 x^2$ for $x > 0.1$,

where $x = \Delta R/R$.

$a_1 = 521.32$ $b_1 = -1614.86$ $c_1 = 7648.72$

$a_2 = 6.5950$ $b_2 = 370.37$ $c_2 = 0.00$

Time: Relative

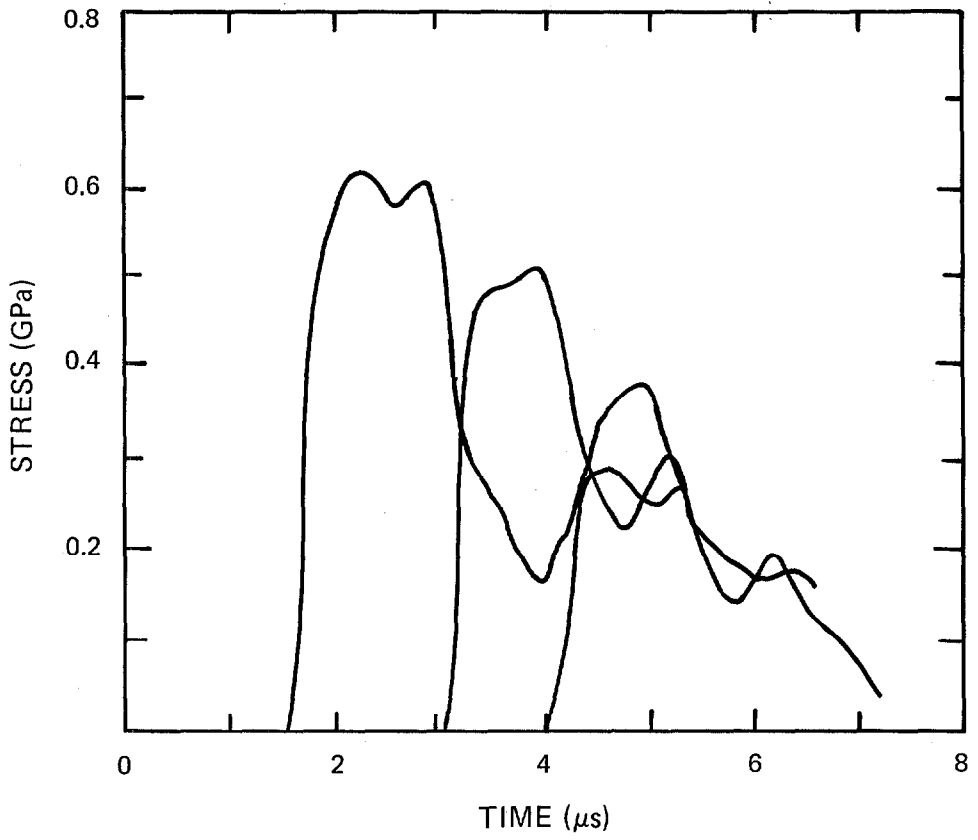

TARGET

Material: Devonian gas shale (shock direction normal to bedding plane), Lincoln County, West Virginia

Experiment type: Embedded Manganin gage

Experimenter: Bart Olinger

Shot no.: 56-77-54 **Date:** April 18, 1977

Diameter: 40.0 mm

Density: 2.73 g/cm³

C_L = 3.79 mm/μs

IMPACTOR

OFHC copper, 5.10 mm thick, backed with low-density polyurethane foam, mounted on 51-mm-diam aluminum alloy projectile

Impact velocity: 0.409 mm/μs

TRANSDUCER

Two-terminal, 50-Ω Manganin gage

Locations from impact surface: 2.02 mm, 6.84 mm, and 10.93 mm

Heat treatment: Annealed

Encapsulation: None

Calibration: J. W. Hopson and J. W. Taylor calibration formula for Manganin gages

$$\sigma = a_1 x + b_1 x^2 + c_1 x^3 \text{ for } x < 0.1,$$

$$\sigma = a_2 + b_2 x + c_2 x^2 \text{ for } x > 0.1,$$

where $x = \Delta R/R$.

$$a_1 = 521.32 \quad b_1 = -1614.86 \quad c_1 = 7648.72$$

$$a_2 = 6.5950 \quad b_2 = 370.37 \quad c_2 = 0.00$$

Time: Relative

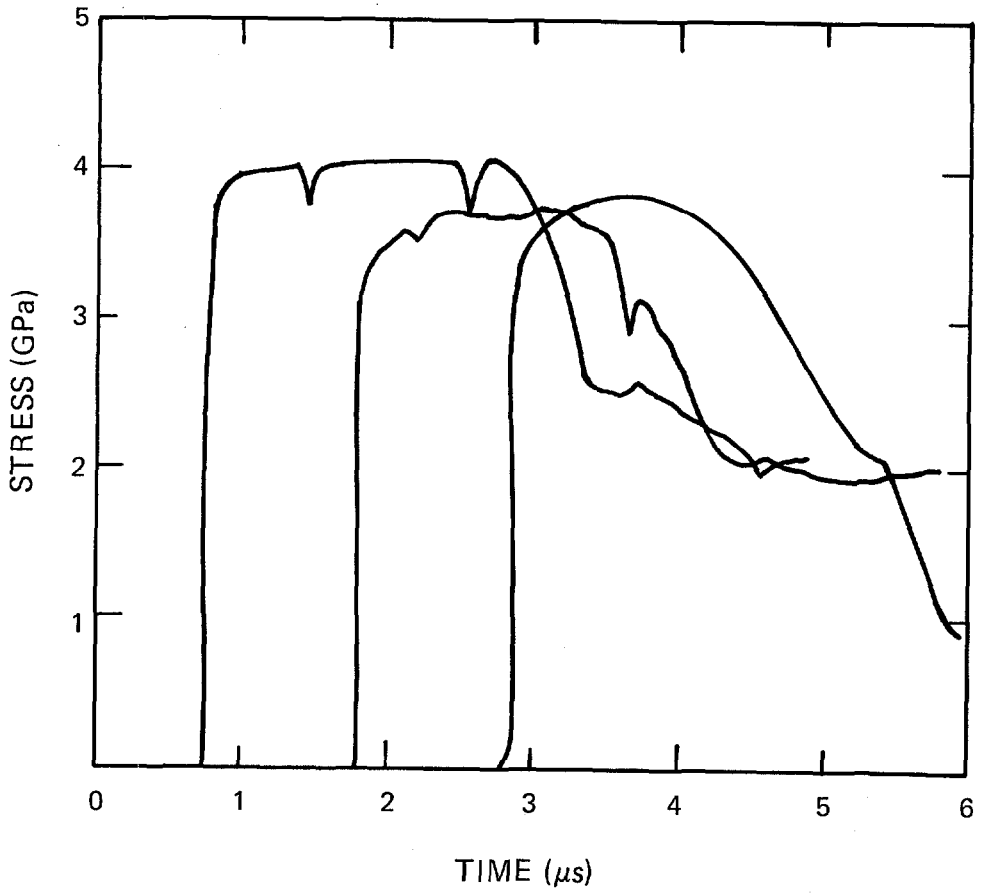

TARGET

Material: Diabase

Experiment type: Free-surface capacitor

Experimenter: J. W. Taylor

Reference: R. G. McQueen, S. P. Marsh, J. W. Taylor, J. N. Fritz, and W. J. Carter (1970)

Shot no.: 56-64-297 **Date:** June 10, 1964

Thickness: 22.15 mm **Diameter:** 152 mm

Density: 3.01 g/cm³

$C_L = 6.88$ mm/ μ s $C_S = 3.81$ mm/ μ s

IMPACTOR

Diabase, 22.15 mm thick, mounted on 165-mm-diam aluminum alloy projectile

Impact velocity: 0.864 mm/ μ s

TRANSDUCER

Free-surface capacitor

Time: Relative

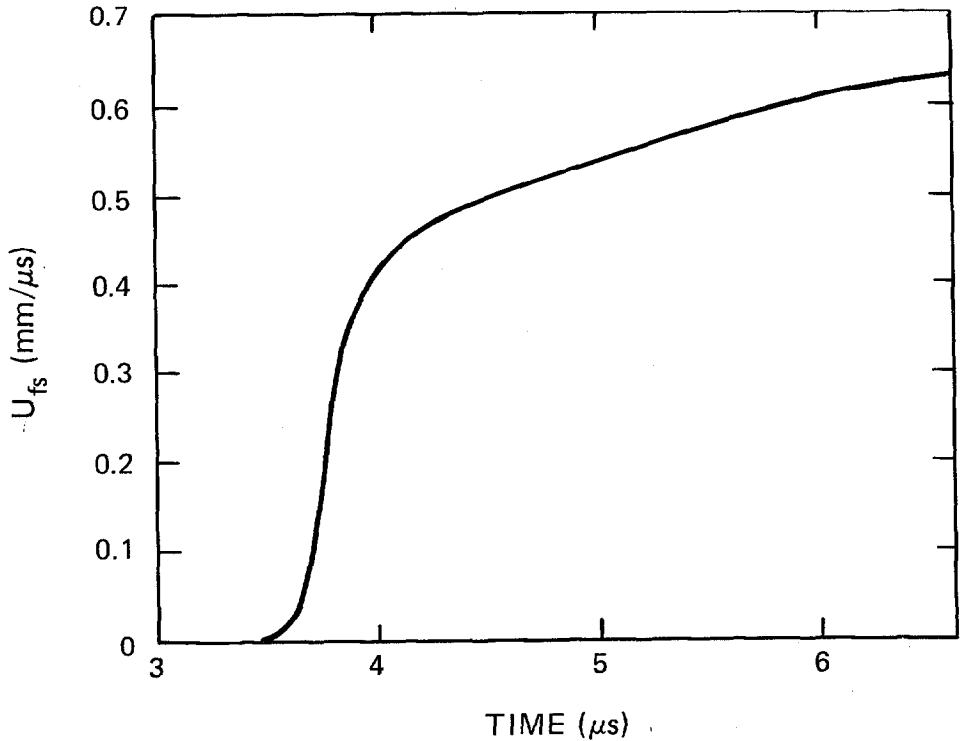

TARGET

Material: Silicon dioxide, SiO₂; gray Arkansas novaculite
Experiment type: ASM probe
Experimenter: J. A. Morgan and J. N. Fritz
Reference: Timmerhaus and Barber (1979)
Shot no.: M 103 Date: August 12, 1976
Thickness: 3.00 mm Diameter: 28 mm
Density: 2.655 g/cm³

IMPACTOR

2024 aluminum, 6.35 mm thick, mounted on 29-mm-diam polycarbonate projectile
Impact velocity: 4.75 mm/ μ s

TRANSDUCER

ASM probe
Coil radius: 6.93 mm Initial coil spacing: 4.27 mm

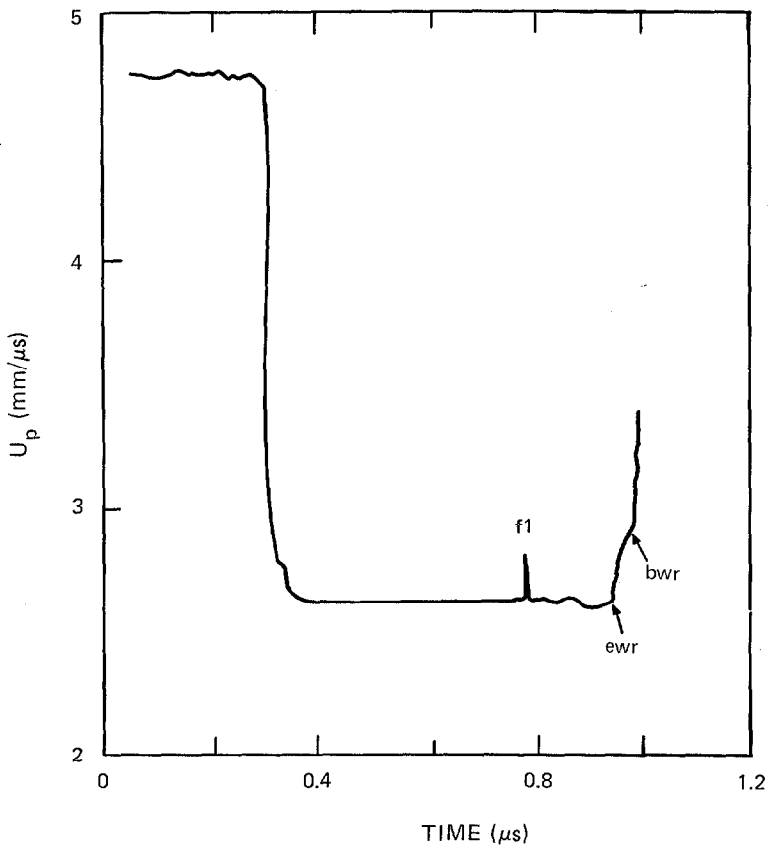

PLASTICS

TARGET

Material: Lexan
Experiment type: Embedded Manganin gage
Experimenter: Bart Olinger
Shot no.: 56-79-23 **Date:** May 17, 1979
Diameter: 38.1 mm
Density: 1.197 g/cm³
C_L = 2.30 mm/μs **C_S** = 0.97 mm/μs

IMPACTOR

Lexan, 3.1 mm thick, backed with low-density polyurethane foam, mounted on 51-mm-diam aluminum alloy projectile
Impact velocity: 0.409 mm/μs

TRANSDUCER

Two-terminal, 50-Ω Manganin gage
Locations from impact surface: 3.1 mm and 9.2 mm
Heat treatment: Annealed
Encapsulation: None
Calibration: J. W. Hopson and J. W. Taylor calibration formula for Manganin gages
 $\sigma = a_1 x + b_1 x^2 + c_1 x^3$ for $x < 0.1$,
 $\sigma = a_2 + b_2 x + c_2 x^2$ for $x > 0.1$,
where $x = \Delta R/R$.
 $a_1 = 521.32$ $b_1 = -1614.86$ $c_1 = 7648.72$
 $a_2 = 6.5950$ $b_2 = 370.37$ $c_2 = 0.00$
Time: Relative

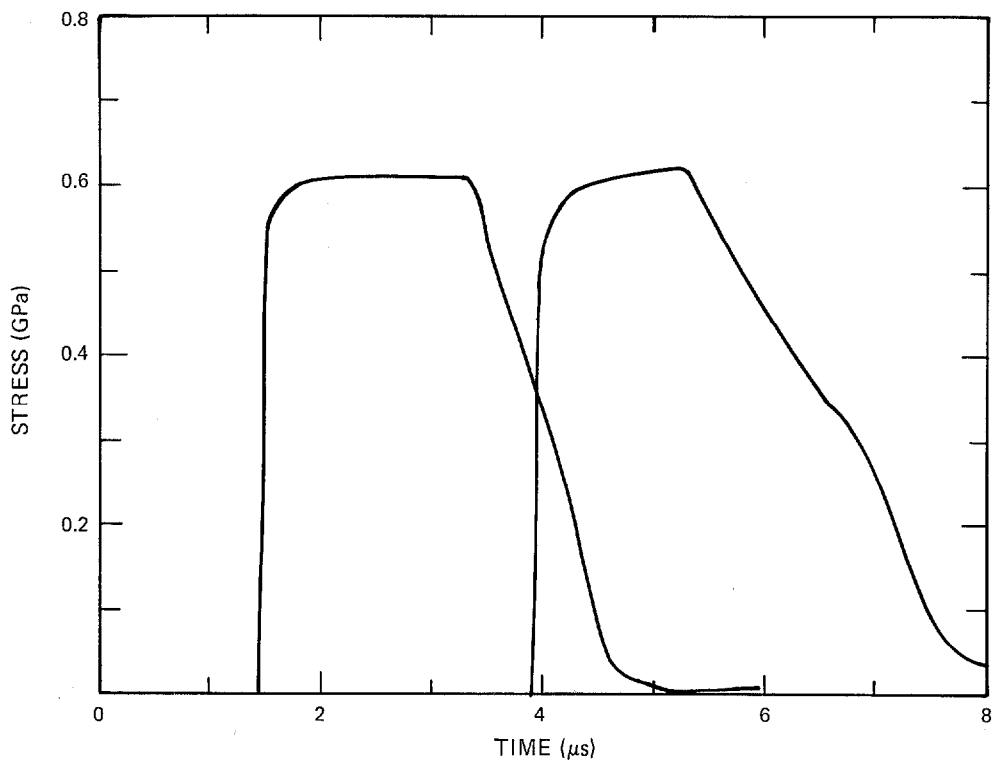

TARGET

Material: Polyethylene
Experiment type: ASM probe
Experimenters: J. N. Fritz and J. A. Morgan
Shot no.: M 93 **Date:** June 12, 1974

HE SHOT GEOMETRY

P-081 lens/203 mm Comp B/14.46 mm OFHC copper//
7.89 mm polyethylene/f- 8.99 mm lead glass/3.53 mm air//

SHOT COMPONENTS

Polyethylene
Density: 0.916 g/cm³
 $C_L = 2.04$ mm/ μ s $C_S = 0.66$ mm/ μ s
OFHC copper
Density: 8.93 g/cm³
 $C_L = 4.76$ mm/ μ s $C_S = 2.33$ mm/ μ s
Lead glass
Density: 5.085 g/cm³
 $C_L = 3.62$ mm/ μ s $C_S = 2.10$ mm/ μ s

TRANSDUCER

ASM probe
Coil radius: 28.64 mm **Initial coil spacing:** 20.41 mm

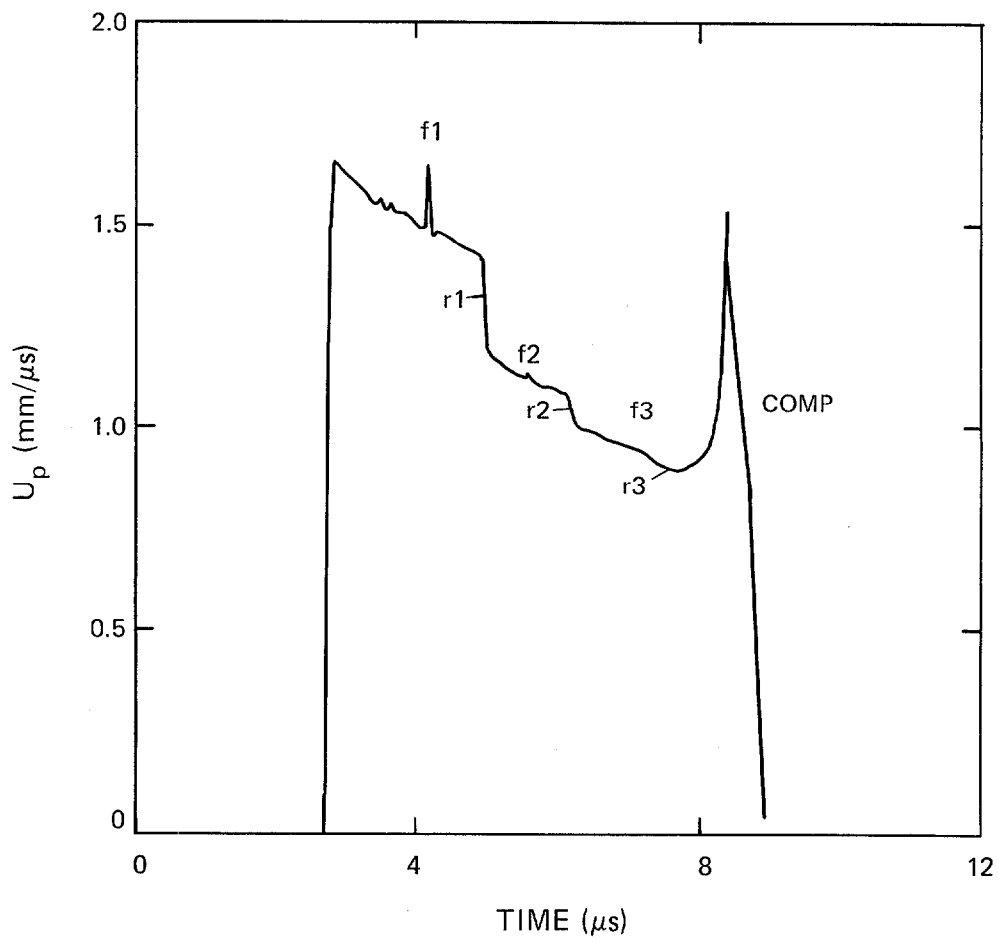

TARGET **Material:** Polymethyl methacrylate (PMMA)
Experiment type: Embedded Manganin gage
Experimenter: Bart Olinger
Shot no.: 56-78-28 **Date:** June 26, 1978
Diameter: 38.1 mm
Density: 1.187 g/cm³
C_L = 2.76 mm/μs **C_S =** 1.38 mm/μs

IMPACTOR PMMA, 3.00 mm thick, backed with low-density polyurethane foam,
mounted on 51-mm-diam aluminum alloy projectile
Impact velocity: 0.12 mm/μs

TRANSDUCER Two-terminal, 50-Ω Manganin gage
Locations from impact surface: 1.05 mm, 5.17 mm, and 9.27 mm
Heat treatment: Annealed
Encapsulation: None
Calibration: J. W. Hopson and J. W. Taylor calibration formula
for Manganin gages
 $\sigma = a_1 x + b_1 x^2 + c_1 x^3$ for $x < 0.1$,
 $\sigma = a_2 + b_2 x + c_2 x^2$ for $x > 0.1$,
where $x = \Delta R/R$.
a₁ = 521.32 **b₁ =** -1614.86 **c₁ =** 7648.72
a₂ = 6.5950 **b₂ =** 370.37 **c₂ =** 0.00
Time: Relative

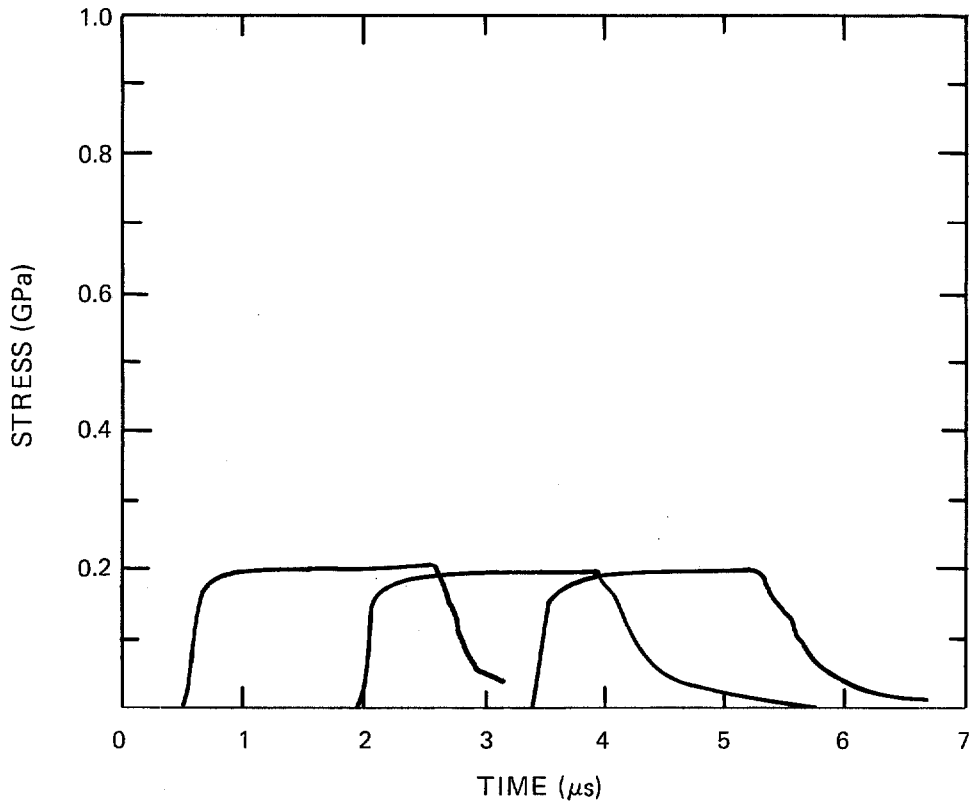

TARGET

Material: Polymethyl methacrylate (PMMA)
Experiment type: Embedded Manganin gage
Experimenter: Bart Olinger
Shot no.: 56-78-29 **Date:** June 26, 1978
Diameter: 38.1 mm
Density: 1.187 g/cm³
C_L = 2.76 mm/μs **C_S** = 1.38 mm/μs

IMPACTOR

PMMA, 3.00 mm thick, backed with low-density polyurethane foam, mounted on 51-mm-diam aluminum alloy projectile
Impact velocity: 0.47 mm/μs

TRANSDUCER

Two-terminal, 50-Ω Manganin gage
Locations from impact surface: 2.05 mm and 8.16 mm
Heat treatment: Annealed
Encapsulation: None
Calibration: J. W. Hopson and J. W. Taylor calibration formula for Manganin gages
 $\sigma = a_1 x + b_1 x^2 + c_1 x^3$ for $x < 0.1$,
 $\sigma = a_2 + b_2 x + c_2 x^2$ for $x > 0.1$,
where $x = \Delta R/R$.
 $a_1 = 521.32$ $b_1 = -1614.86$ $c_1 = 7648.72$
 $a_2 = 6.5950$ $b_2 = 370.37$ $c_2 = 0.00$
Time: Relative

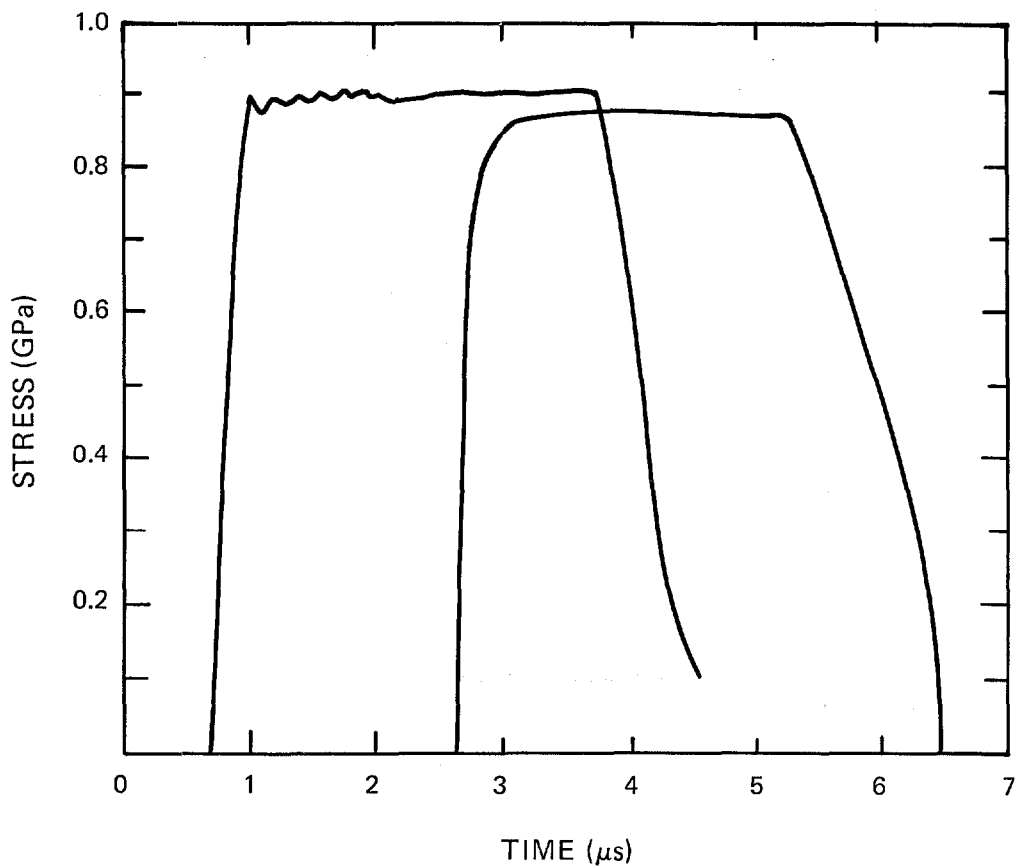

TARGET

Material: Polymethyl methacrylate (PMMA)
Experiment type: Embedded Manganin gage
Experimenter: Bart Olinger
Shot no.: 56-78-30 **Date:** June 27, 1978
Diameter: 38.1 mm
Density: 1.187 g/cm³
C_L = 2.76 mm/μs **C_s** = 1.38 mm/μs

IMPACTOR

PMMA, 3.00 mm thick, backed with low-density polyurethane foam,
mounted on 51-mm-diam aluminum alloy projectile
Impact velocity: 0.25 mm/μs

TRANSDUCER

Two-terminal, 50-Ω Manganin gage
Locations from impact surface: 1.05 mm and 7.15 mm
Heat treatment: Annealed
Encapsulation: None
Calibration: J. W. Hopson and J. W. Taylor calibration formula
for Manganin gages
 $\sigma = a_1 x + b_1 x^2 + c_1 x^3$ for $x < 0.1$,
 $\sigma = a_2 + b_2 x + c_2 x^2$ for $x > 0.1$,
where $x = \Delta R/R$.
 $a_1 = 521.32$ $b_1 = -1614.86$ $c_1 = 7648.72$
 $a_2 = 6.5950$ $b_2 = 370.37$ $c_2 = 0.00$
Time: Relative

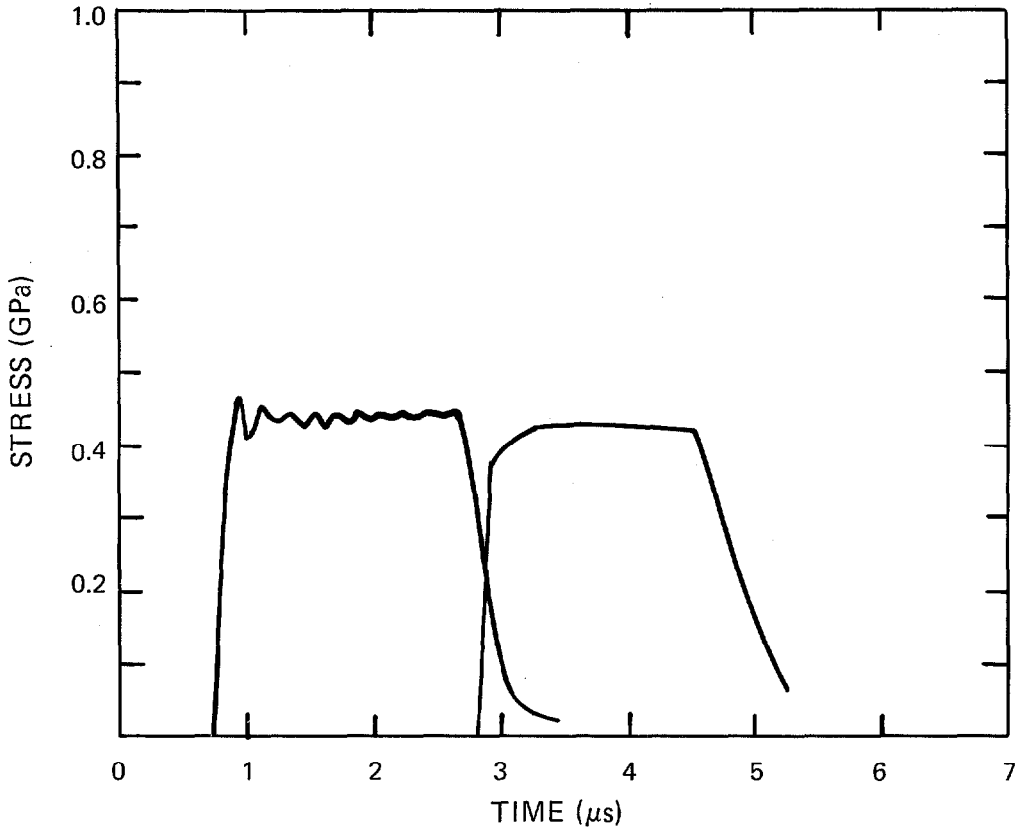

TARGET

Material: Polymethyl methacrylate (PMMA)
Experiment type: Embedded Manganin gage
Experimenter: Bart Olinger
Shot no.: 56-78-31 Date: June 27, 1978
Diameter: 38.1 mm
Density: 1.187 g/cm³
 $C_L = 2.76$ mm/ μ s $C_S = 1.38$ mm/ μ s

IMPACTOR

PMMA, 3.00 mm thick, backed with low-density polyurethane foam,
mounted on 51-mm-diam aluminum alloy projectile
Impact velocity: 0.37 mm/ μ s

TRANSDUCER

Two-terminal, 50- Ω Manganin gage
Locations from impact surface: 2.05 mm, 6.14 mm, and 10.25 mm
Heat treatment: Annealed
Encapsulation: None
Calibration: J. W. Hopson and J. W. Taylor calibration formula
for Manganin gages
 $\sigma = a_1 x + b_1 x^2 + c_1 x^3$ for $x < 0.1$,
 $\sigma = a_2 + b_2 x + c_2 x^2$ for $x > 0.1$,
where $x = \Delta R/R$.
 $a_1 = 521.32$ $b_1 = -1614.86$ $c_1 = 7648.72$
 $a_2 = 6.5950$ $b_2 = 370.37$ $c_2 = 0.00$
Time: Relative

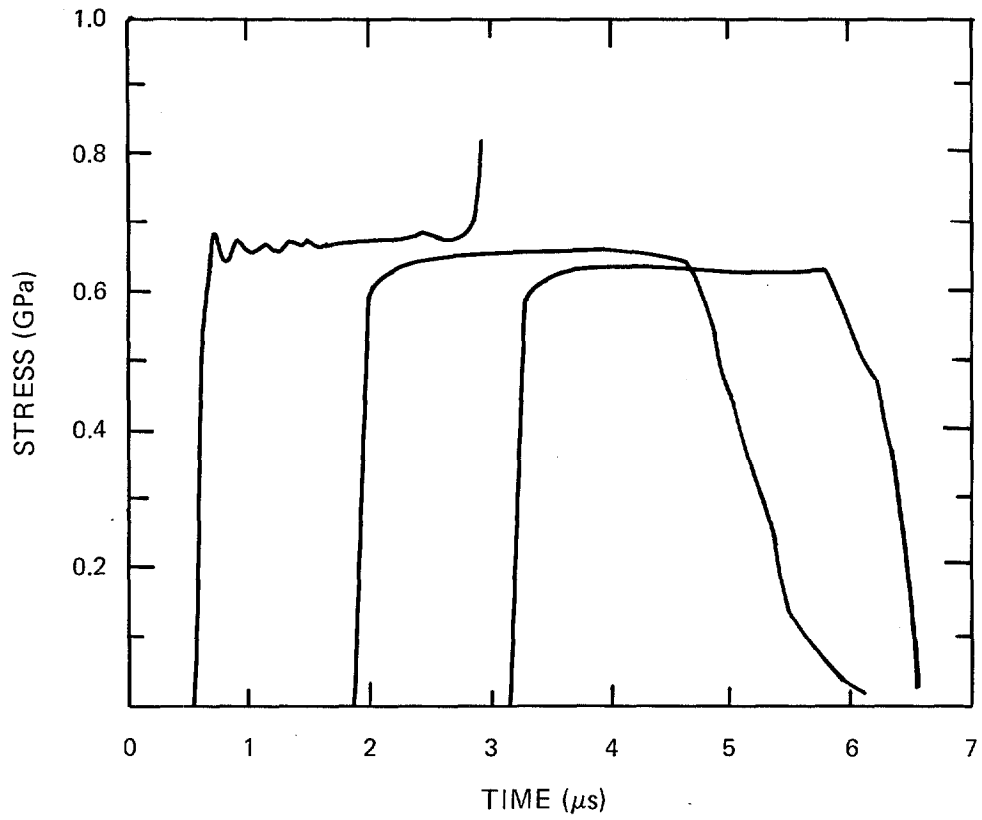

**HIGH EXPLOSIVES,
HIGH-EXPLOSIVE SIMULANTS,
AND PROPELLANTS**

TARGET

Material: Baratol, 76 wt% barium nitrate/24 wt% TNT
Experiment type: Embedded Manganin gage
Experimenter: Bart Olinger
Shot no.: 56-77-98 **Date:** October 20, 1977
Diameter: 38.1 mm
Density: 2.61 g/cm³
C_L = 2.90 mm/μs **C_S** = 1.54 mm/μs

IMPACTOR

Baratol, 3.05 mm thick, backed with low-density polyurethane foam, mounted on 51-mm-diam aluminum alloy projectile
Impact velocity: 0.176 mm/μs

TRANSDUCER

Two-terminal, 50-Ω Manganin gage
Locations from impact surface: 2.04 mm, 6.11 mm, and 10.18 mm
Heat treatment: Annealed
Encapsulation: None
Calibration: J. W. Hopson and J. W. Taylor calibration formula for Manganin gages
 $\sigma = a_1 x + b_1 x^2 + c_1 x^3$ for $x < 0.1$,
 $\sigma = a_2 + b_2 x + c_2 x^2$ for $x > 0.1$,
where $x = \Delta R/R$.
 $a_1 = 521.32$ $b_1 = -1614.86$ $c_1 = 7648.72$
 $a_2 = 6.5950$ $b_2 = 370.37$ $c_2 = 0.00$
Time: Relative

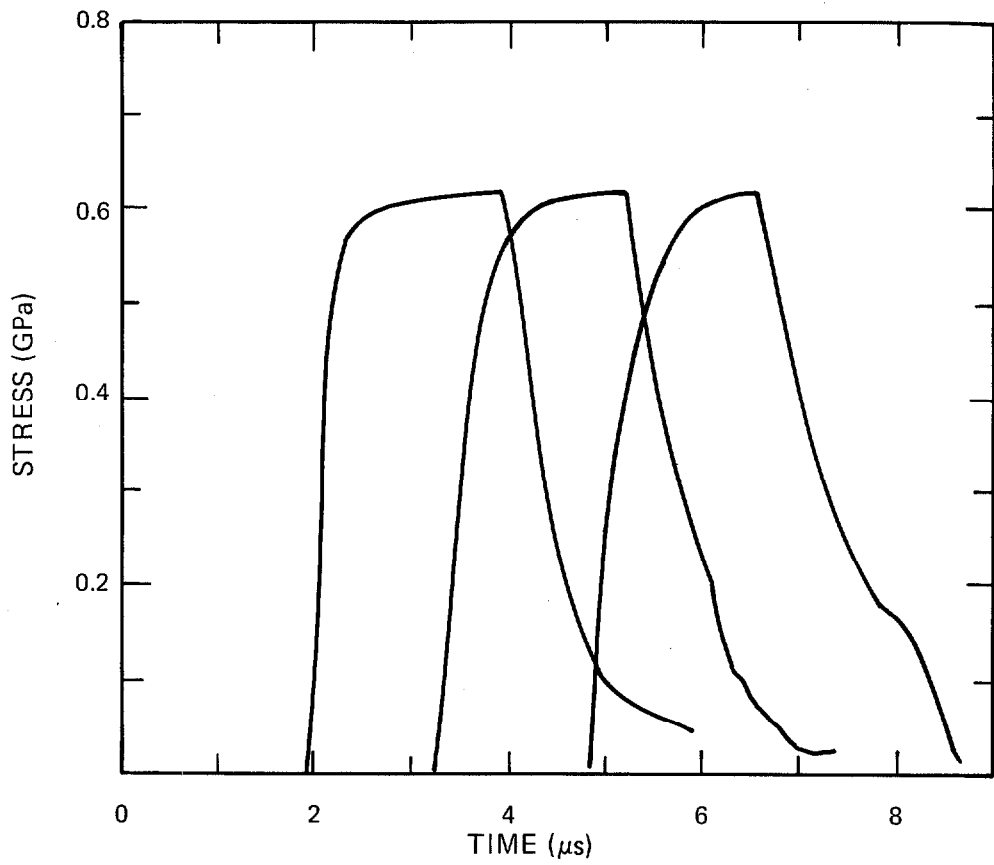

TARGET

Material: Comp B
Experiment type: ASM probe
Experimenter: W. C. Davis
Reference: Davis (1976)
Shot no.: C 4152 Date: October 23, 1974

HE SHOT GEOMETRY P-080 lens/25.4 mm Comp B/0.075 mm aluminum//
6.35 mm Teflon//

SHOT COMPONENTS

Comp B
Density: 1.73 g/cm³
C_L = 3.12 mm/μs C_S = 1.71 mm/μs
Teflon
Density: 2.14 g/cm³
C_L = 1.23 mm/μs C_S = 0.41 mm/μs

TRANSDUCER

ASM probe
Coil radius: 18.62 mm Initial coil spacing: 6.78 mm

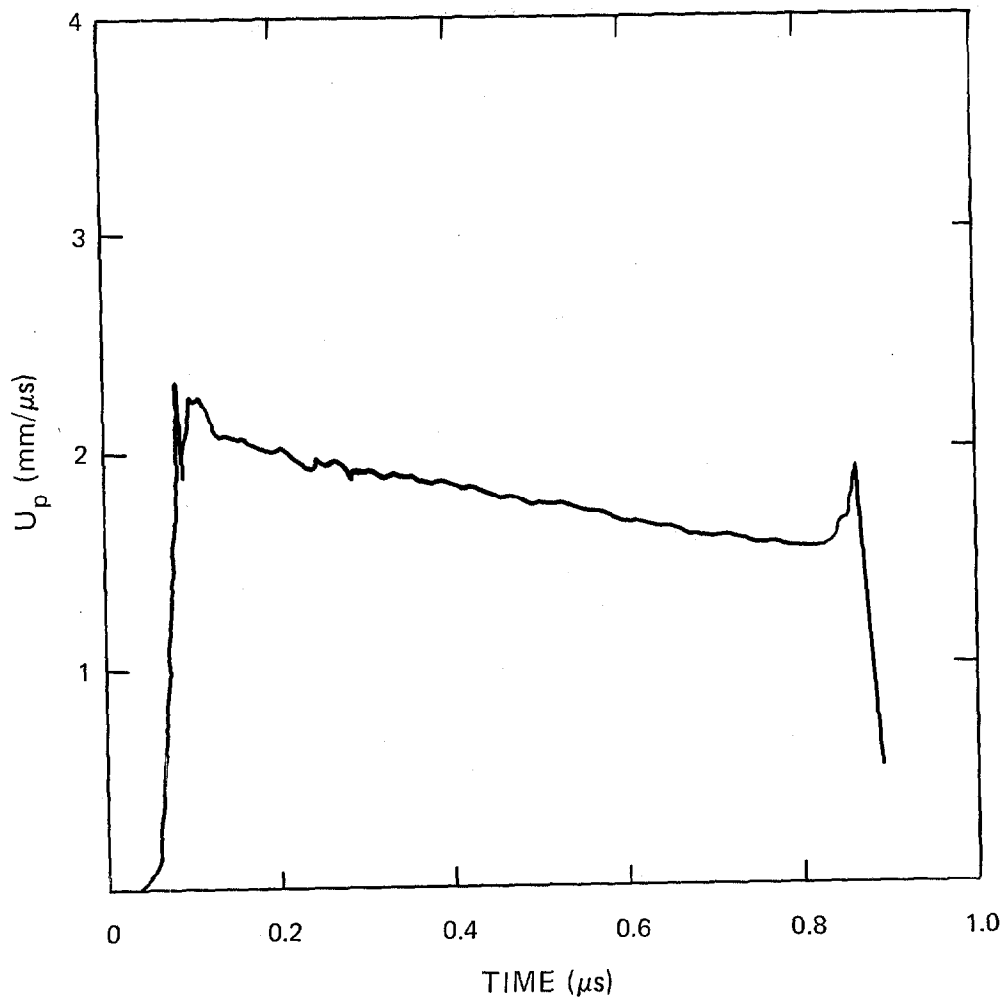

TARGET

Material: Comp B-3, 60 wt% RDX/40 wt% TNT
Experiment type: Embedded Manganin gage
Experimenter: Bart Olinger
Shot no.: 56-77-104 **Date:** October 26, 1977
Diameter: 38.1 mm
Density: 1.70 g/cm³
C_L = 3.00 mm/μs **C_S** = 1.61 mm/μs

IMPACTOR

Comp B-3, 3.05 mm thick, backed with low-density polyurethane foam, mounted on 51-mm-diam aluminum alloy projectile
Impact velocity: 0.266 mm/μs

TRANSDUCER

Two-terminal, 50-Ω Manganin gage
Locations from impact surface: 2.04 mm, 6.11 mm, and 10.18 mm
Heat treatment: Annealed
Encapsulation: None
Calibration: J. W. Hopson and J. W. Taylor calibration formula for Manganin gages
 $\sigma = a_1 x + b_1 x^2 + c_1 x^3$ for $x < 0.1$,
 $\sigma = a_2 + b_2 x + c_2 x^2$ for $x > 0.1$,
where $x = \Delta R/R$.
 $a_1 = 521.32$ $b_1 = -1614.86$ $c_1 = 7648.72$
 $a_2 = 6.5950$ $b_2 = 370.37$ $c_2 = 0.00$
Time: Relative

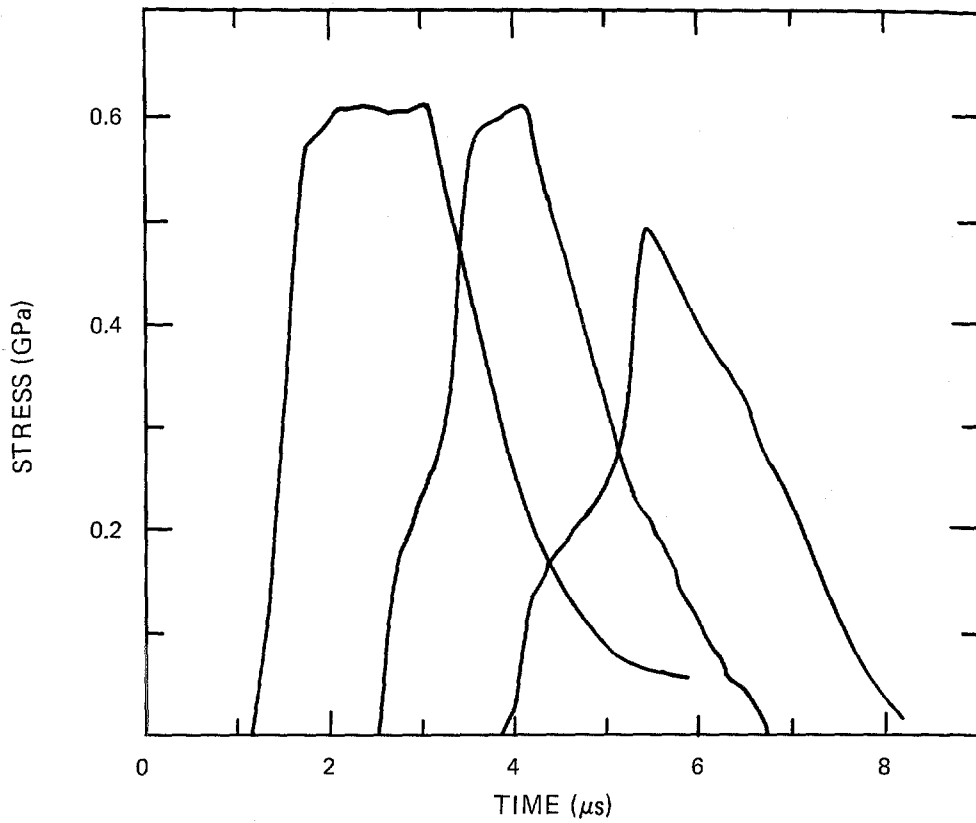

TARGET

Material: Inert 900-10, 48 wt% Pentek/46 wt% barium nitrate, Ba(NO₃)₂/2.8 wt% nitrocellulose (NC), 3.2 wt% tris-beta chloroethyl-phosphate (CEF)

Experiment type: Embedded Manganin gage

Experimenter: Bart Olinger

Shot no.: 56-77-88 **Date:** September 8, 1977

Diameter: 38.1 mm

Density: 1.88 g/cm³

$C_L = 3.21$ mm/ μ s $C_S = 1.57$ mm/ μ s

IMPACTOR

Inert 900-10, 3.05 mm thick, backed with low-density polyurethane foam, mounted on 51-mm-diam aluminum alloy projectile

Impact velocity: 0.210 mm/ μ s

TRANSDUCER

Two-terminal, 50- Ω Manganin gage

Locations from impact surface: 2.04 mm, 6.11 mm, and 10.18 mm

Heat treatment: Annealed

Encapsulation: None

Calibration: J. W. Hopson and J. W. Taylor calibration formula for Manganin gages

$\sigma = a_1 x + b_1 x^2 + c_1 x^3$ for $x < 0.1$,

$\sigma = a_2 + b_2 x + c_2 x^2$ for $x > 0.1$,

where $x = \Delta R/R$.

$a_1 = 521.32$ $b_1 = -1614.86$ $c_1 = 7648.72$

$a_2 = 6.5950$ $b_2 = 370.37$ $c_2 = 0.00$

Time: Relative

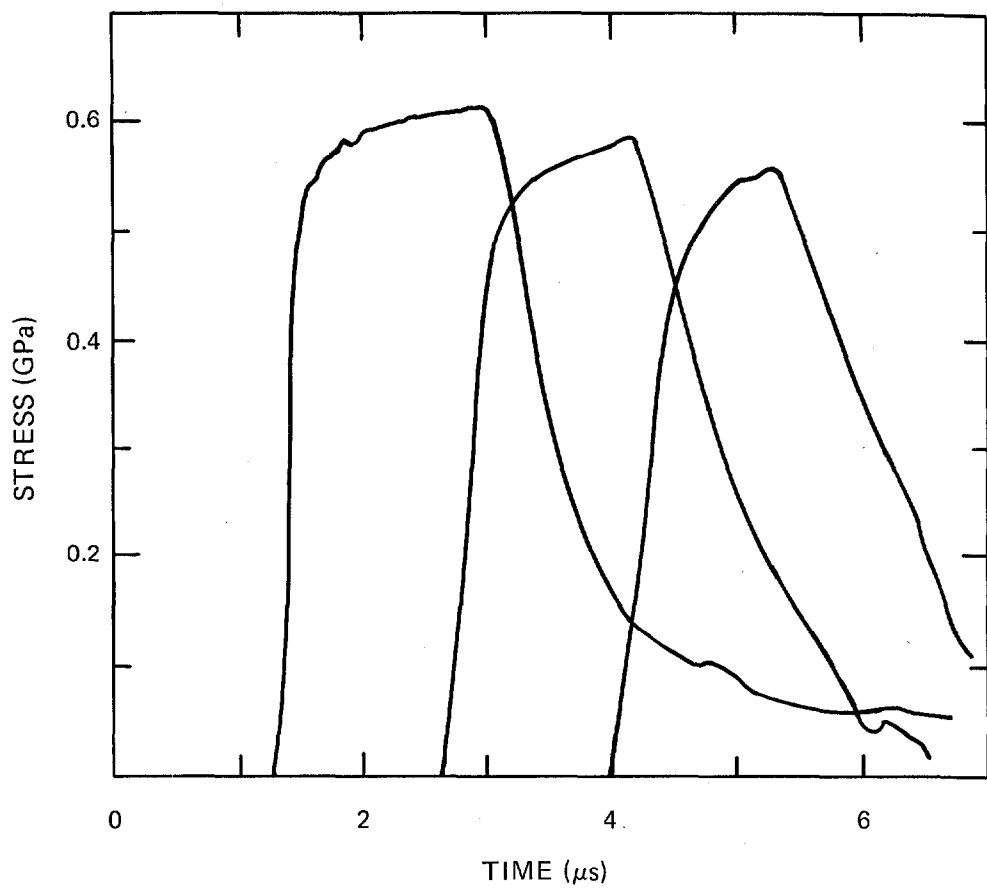

TARGET **Material:** Inert 905-03, 60 wt% cyanuric acid/32 wt% melamine/
4 wt% NC/4 wt% CEF
Experiment type: Embedded Manganin gage
Experimenter: Bart Olinger
Shot no.: 56-77-89 **Date:** September 9, 1977
Diameter: 38.1 mm
Density: 1.60 g/cm³
C_L = 2.22 mm/μs C_S = 0.90 mm/μs

IMPACTOR Inert 905-03, 3.05 mm thick, backed with low-density polyurethane
foam, mounted on 51-mm-diam aluminum alloy projectile
Impact velocity: 0.416 mm/μs

TRANSDUCER Two-terminal, 50-Ω Manganin gage
Locations from impact surface: 2.04 mm, 6.11 mm, and 10.18 mm
Heat treatment: Annealed
Encapsulation: None
Calibration: J. W. Hopson and J. W. Taylor calibration formula
for Manganin gages
 $\sigma = a_1 x + b_1 x^2 + c_1 x^3$ for $x < 0.1$,
 $\sigma = a_2 + b_2 x + c_2 x^2$ for $x > 0.1$,
where $x = \Delta R/R$.
a₁ = 521.32 b₁ = -1614.86 c₁ = 7648.72
a₂ = 6.5950 b₂ = 370.37 c₂ = 0.00
Time: Relative

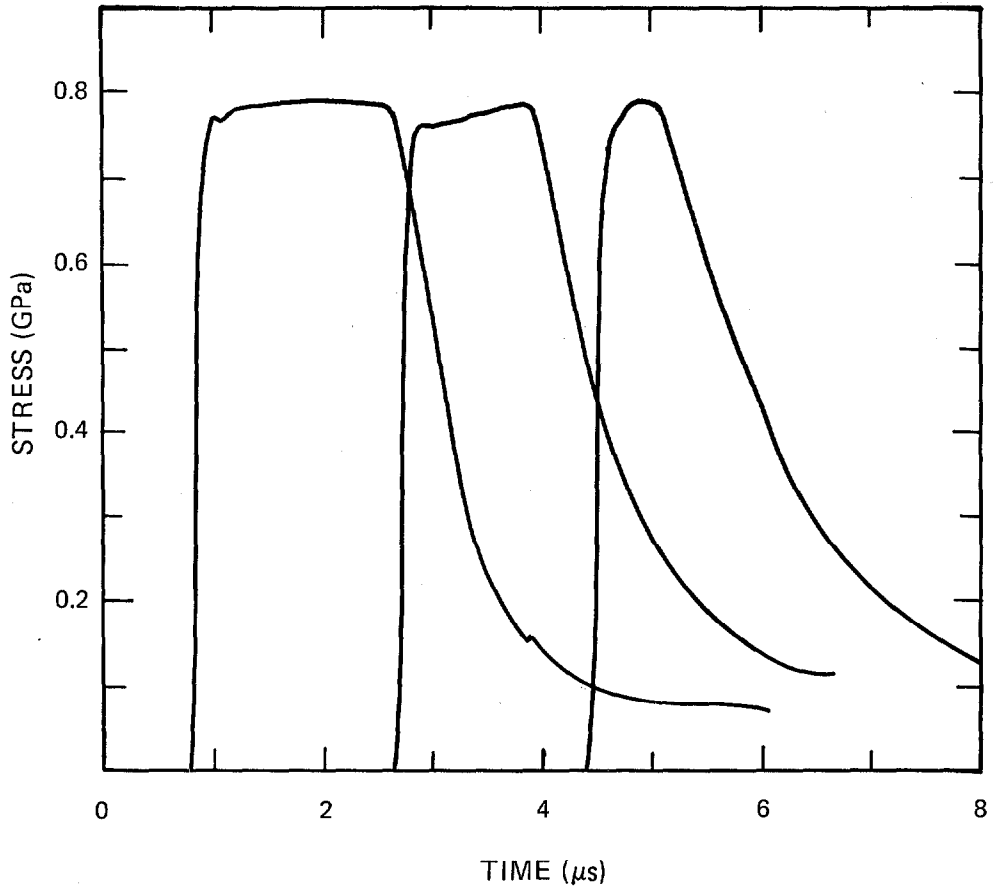

TARGET **Material:** Inert 900-19, 95 wt% cyanuric acid/ 5 wt% Kel-F 800
Experiment type: Embedded Manganin gage
Experimenter: Bart Olinger
Shot no.: 56-77-90 **Date:** September 9, 1977
Diameter: 38.1 mm
Density: 1.64 g/cm³
C_L = 2.59 mm/μs **C_S** = 1.29 mm/μs

IMPACTOR Inert 900-19, 3.05 mm thick, backed with low-density polyurethane foam, mounted on 51-mm-diam aluminum alloy projectile
Impact velocity: 0.298 mm/μs

TRANSDUCER Two-terminal, 50-Ω Manganin gage
Locations from impact surface: 2.04 mm, 6.11 mm, and 10.18 mm
Heat treatment: Annealed
Encapsulation: None
Calibration: J. W. Hopson and J. W. Taylor calibration formula for Manganin gages
 $\sigma = a_1 x + b_1 x^2 + c_1 x^3$ for $x < 0.1$,
 $\sigma = a_2 + b_2 x + c_2 x^2$ for $x > 0.1$,
where $x = \Delta R/R$.
a₁ = 521.32 **b₁** = -1614.86 **c₁** = 7648.72
a₂ = 6.5950 **b₂** = 370.37 **c₂** = 0.00
Time: Relative

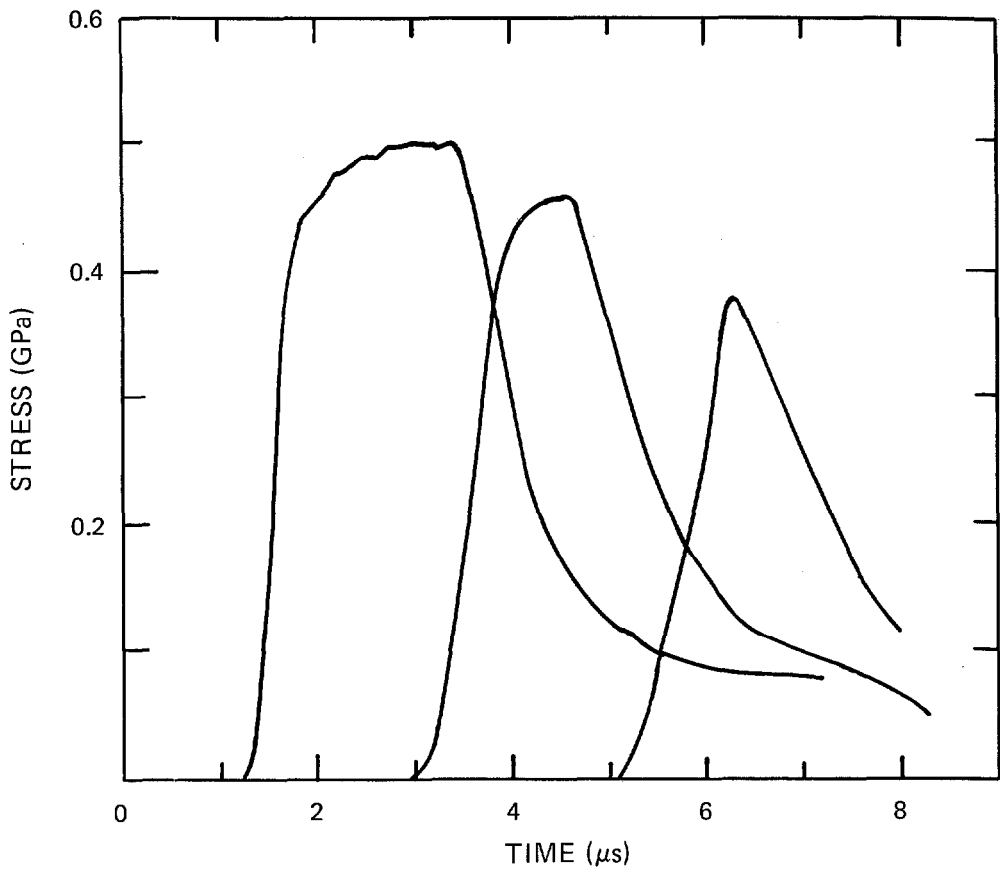

TARGET

Material: PBX 9404
Experiment type: ASM probe
Experimenter: W. C. Davis
Reference: Davis (1976)
Shot no.: F 3603 **Date:** December 16, 1974

HE SHOT GEOMETRY P-080 lens/2.54 mm PBX 9404/0.075 mm aluminum//
6.35 mm Teflon//

SHOT COMPONENTS PBX 9404
Density: 1.84 g/cm³
 $C_L = 2.90$ mm/ μ s $C_S = 1.57$ mm/ μ s
Teflon
Density: 2.14 g/cm³
 $C_L = 1.23$ mm/ μ s $C_S = 0.41$ mm/ μ s

TRANSDUCER

ASM probe
Coil radius: 18.62 mm Initial coil spacing: 6.78 mm

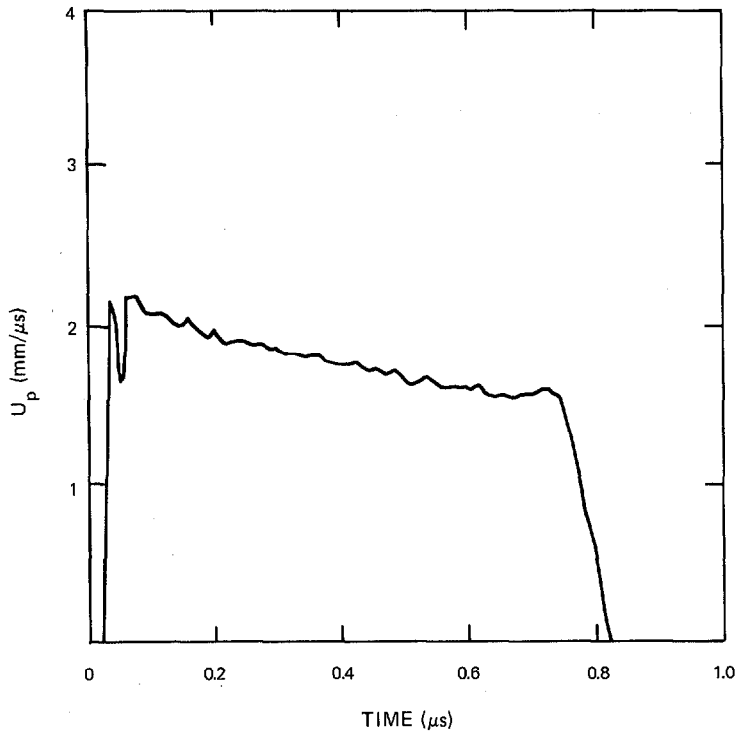

TARGET

Material: PBX 9404
Experiment type: ASM probe
Experimenter: W. C. Davis
Reference: Davis (1976)
Shot no.: F 3608 **Date:** December 18, 1974

HE SHOT GEOMETRY P-080 lens/101.6 mm PBX 9404/0.075 mm aluminum//
6.35 mm Teflon//

SHOT COMPONENTS PBX 9404
Density: 1.84 g/cm³
 $C_L = 2.90$ mm/ μ s $C_S = 1.57$ mm/ μ s
Teflon
Density: 2.14 g/cm³
 $C_L = 1.23$ mm/ μ s $C_S = 0.41$ mm/ μ s

TRANSDUCER ASM probe
Coil radius: 18.62 mm **Initial coil spacing:** 6.78 mm

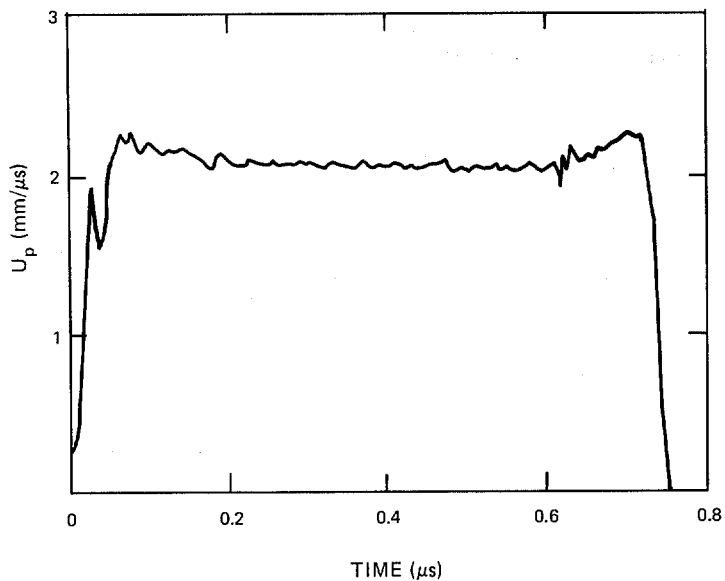

TARGET

Material: PBX 9404

Experiment type: ASM probe

Experimenter: W. C. Davis

Reference: Davis (1976)

Shot no.: F 3609 **Date:** December 19, 1974

HE SHOT GEOMETRY

P-080 lens/25.4 mm PBX 9404/0.075 mm aluminum//
6.35 mm Teflon//

SHOT COMPONENTS

PBX 9404

Density: 1.84 g/cm³

$C_L = 2.90$ mm/ μ s $C_S = 1.57$ mm/ μ s

Teflon

Density: 2.14 g/cm³

$C_L = 1.23$ mm/ μ s $C_S = 0.41$ mm/ μ s

TRANSDUCER

ASM probe

Coil radius: 18.62 mm **Initial coil spacing:** 6.78 mm

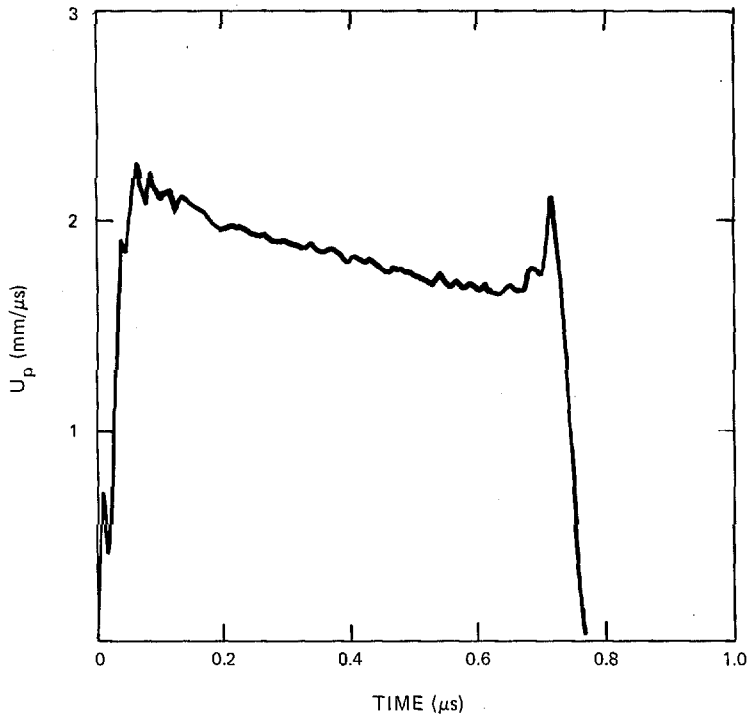

TARGET

Material: PBX 9404
Experiment type: ASM probe
Experimenter: W. C. Davis
Reference: Davis (1976)
Shot no.: F 3652 **Date:** February 26, 1975

HE SHOT GEOMETRY

P-080 lens/6.35 mm PBX 9404/0.025 mm copper//
6.35 mm PBX 9404//

SHOT COMPONENTS

PBX 9404
Density: 1.84 g/cm³
 $C_L = 2.90$ mm/ μ s $C_S = 1.57$ mm/ μ s

TRANSDUCER

ASM probe
Coil radius: 18.62 mm **Initial coil spacing:** 6.78 mm

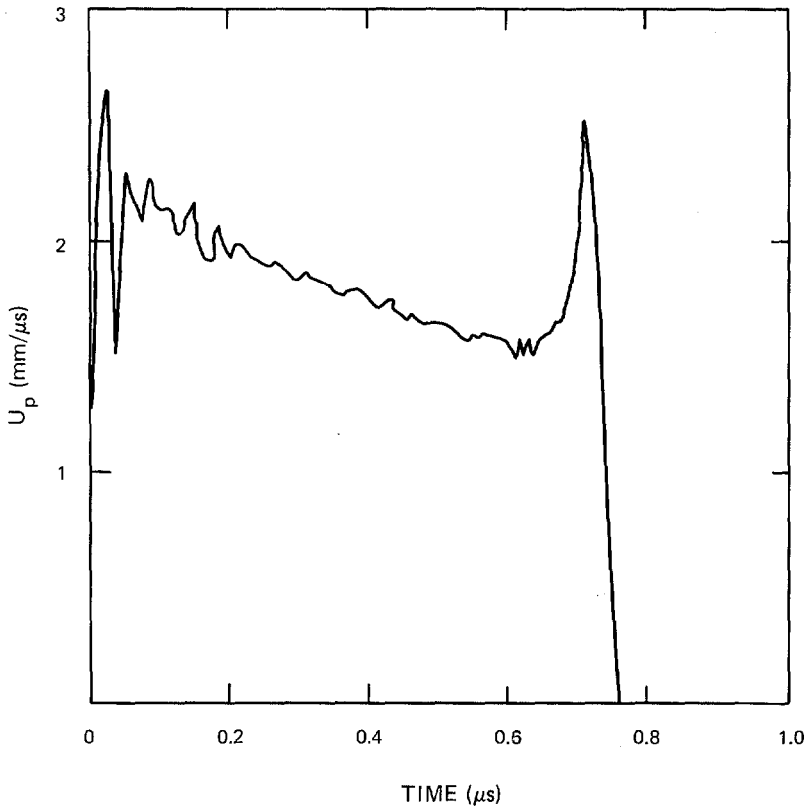

TARGET

Material: PBX 9404
Experiment type: ASM probe
Experimenter: W. C. Davis
Reference: Davis (1976)
Shot no.: F 3653 **Date:** February 26, 1975

HE SHOT GEOMETRY

P-080 lens/25.4 mm PBX 9404/0.075 mm magnesium//
6.35 mm PBX 9404//

SHOT COMPONENTS

PBX 9404
Density: 1.84 g/cm³
 $C_L = 2.90$ mm/ μ s $C_S = 1.57$ mm/ μ s

TRANSDUCER

ASM probe
Coil radius: 18.62 mm **Initial coil spacing:** 6.78 mm

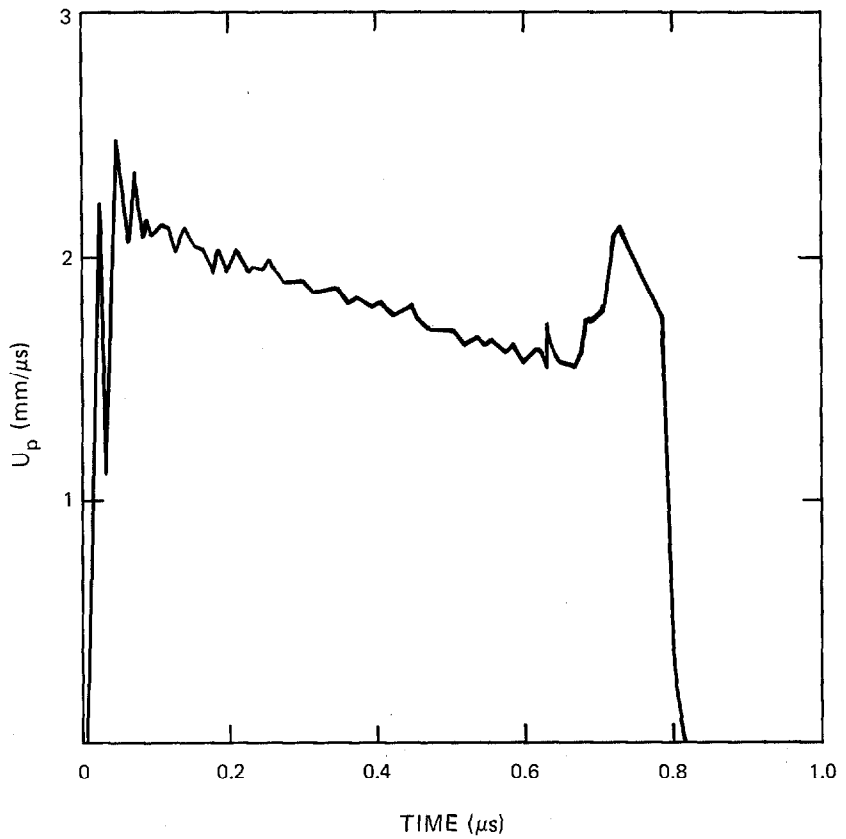

TARGET

Material: PBX 9404
Experiment type: ASM probe
Experimenter: W. C. Davis
Reference: Davis (1976)
Shot no.: F 3669 **Date:** May 12, 1975

HE SHOT GEOMETRY

P-080 lens/25.4 mm PBX 9404/0.075 mm aluminum//
6.34 mm Teflon//

SHOT COMPONENTS

PBX 9404
Density: 1.84 g/cm³
 $C_L = 2.90$ mm/ μ s $C_S = 1.57$ mm/ μ s
Teflon
Density: 2.14 g/cm³
 $C_L = 1.23$ mm/ μ s $C_S = 0.41$ mm/ μ s

TRANSDUCER

ASM probe
Coil radius: 18.62 mm **Initial coil spacing:** 6.77 mm

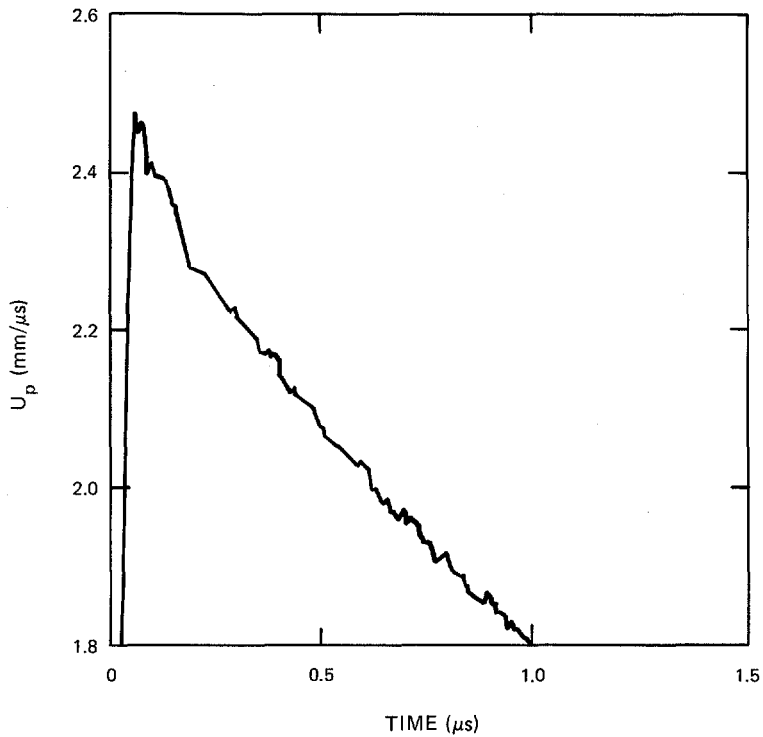

TARGET

Material: PBX 9404
Experiment type: ASM probe
Experimenter: W. C. Davis
Reference: Davis (1976)
Shot no.: F 3788 **Date:** August 7, 1975

HE SHOT GEOMETRY

P-080 lens/50.8 mm PBX 9404/0.075 mm aluminum//
6.35 mm Teflon//

SHOT COMPONENTS

PBX 9404
Density: 1.84 g/cm³
 $C_L = 2.90$ mm/ μ s $C_s = 1.51$ mm/ μ s
Teflon
Density: 2.14 g/cm³
 $C_L = 1.23$ mm/ μ s $C_s = 0.41$ mm/ μ s

TRANSDUCER

ASM probe
Coil radius: 18.62 mm **Initial coil spacing:** 6.78 mm

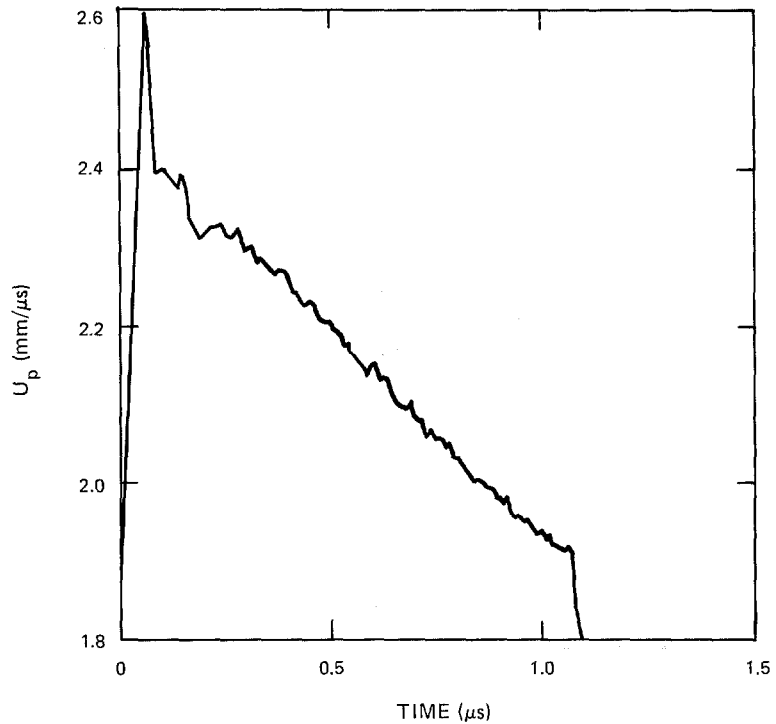

TARGET

Material: PBX 9404
Experiment type: ASM probe
Experimenter: W. C. Davis
Reference: Davis (1976)
Shot no.: F 3789 Date: August 7, 1975

HE SHOT GEOMETRY

P-080 lens/101.6 mm PBX 9404/0.075 mm aluminum//
6.35 mm Teflon//

SHOT COMPONENTS

PBX 9404
Density: 1.84 g/cm³
C_L = 2.90 mm/μs C_s = 1.57 mm/μs
Teflon
Density: 2.14 g/cm³
C_L = 1.23 mm/μs C_s = 0.41 mm/μs

TRANSDUCER

ASM probe
Coil radius: 18.62 mm Initial coil spacing: 6.78 mm

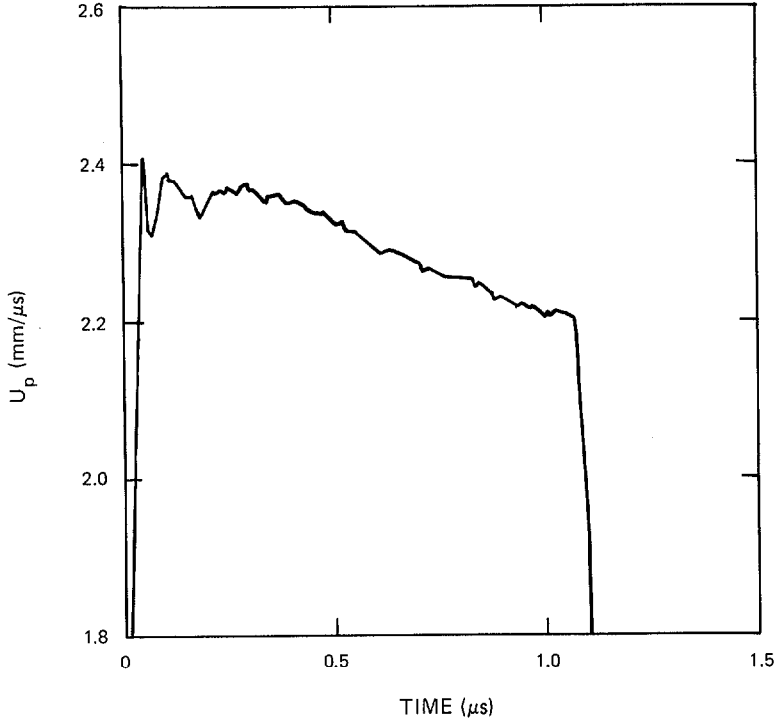

TARGET

Material: PBX 9404
Experiment type: ASM probe
Experimenter: W. C. Davis
Reference: Davis (1976)
Shot no.: F 3790 Date: August 8, 1975

HE SHOT GEOMETRY

P-080 lens/203.2 mm PBX 9404/0.075 mm aluminum//
6.36 mm Teflon//

SHOT COMPONENTS

PBX 9404
Density: 1.84 g/cm³
C_L = 2.90 mm/μs C_S = 1.57 mm/μs
Teflon
Density: 2.14 g/cm³
C_L = 1.23 mm/μs C_S = 0.41 mm/μs

TRANSDUCER

ASM probe
Coil radius: 18.62 mm Initial coil spacing: 6.79 mm

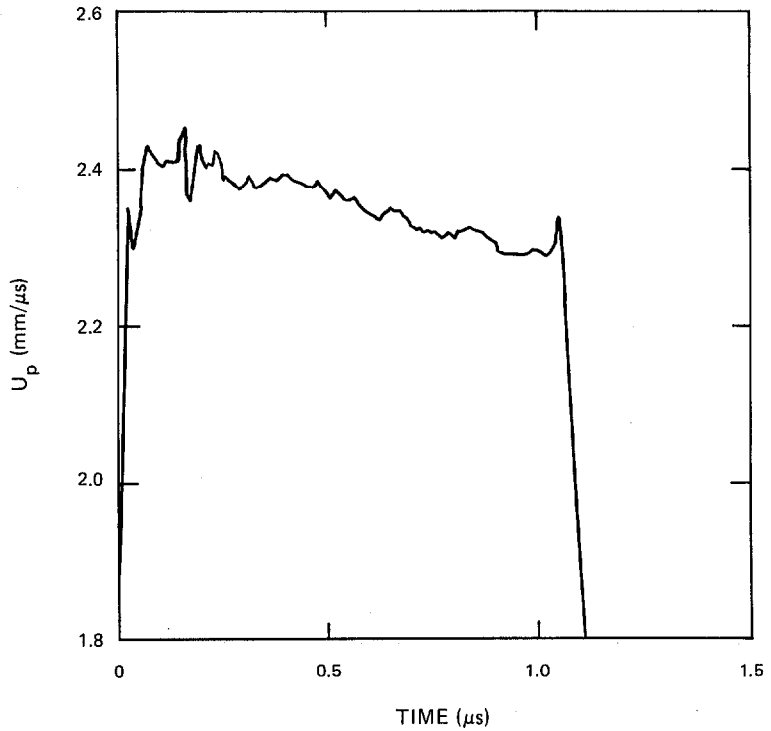

TARGET

Material: PBX 9404
Experiment type: ASM probe
Experimenter: W. C. Davis
Reference: Davis (1976)
Shot no.: F 3796 **Date:** August 15, 1975

HE SHOT GEOMETRY

P-080 lens/25.4 mm PBX 9404/0.075 mm aluminum//
6.36 mm Teflon//

SHOT COMPONENTS

PBX 9404
Density: 1.84 g/cm³
 $C_L = 2.90$ mm/ μ s $C_S = 1.57$ mm/ μ s
Teflon
Density: 2.14 g/cm³
 $C_L = 1.23$ mm/ μ s $C_S = 0.41$ mm/ μ s

TRANSDUCER

ASM probe
Coil radius: 18.62 mm **Initial coil spacing:** 6.79 mm

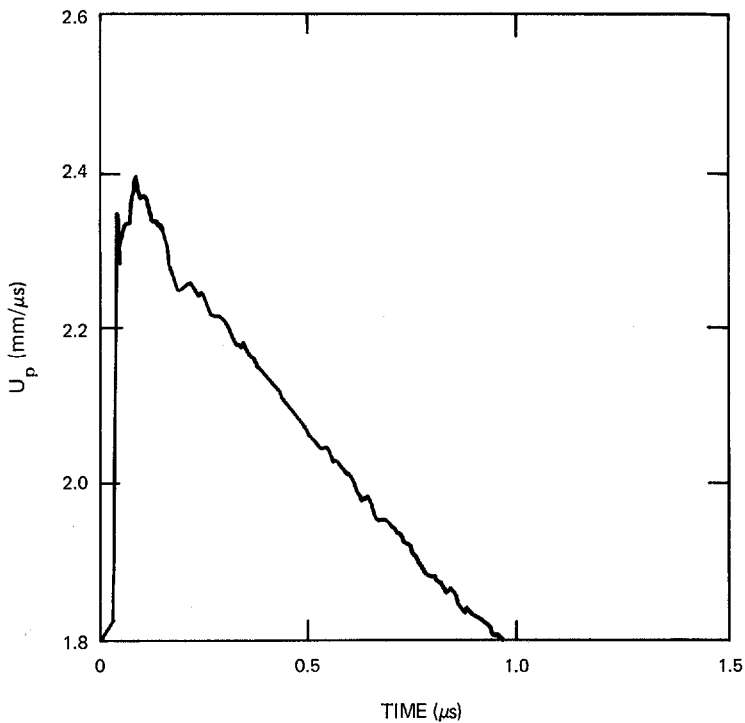

TARGET

Material: PBX 9404
Experiment type: ASM probe
Experimenter: W. C. Davis
Reference: Davis (1976)
Shot no.: F 3799 **Date:** August 20, 1975

HE SHOT GEOMETRY

P-080 lens/50.8 mm PBX 9404/0.075 mm aluminum//
6.36 mm Teflon//

SHOT COMPONENTS

PBX 9404
Density: 1.84 g/cm³
C_L = 2.90 mm/μs C_S = 1.57 mm/μs
Teflon
Density: 2.14 g/cm³
C_L = 1.23 mm/μs C_S = 0.41 mm/μs

TRANSDUCER

ASM probe
Coil radius: 18.62 mm **Initial coil spacing:** 6.79 mm

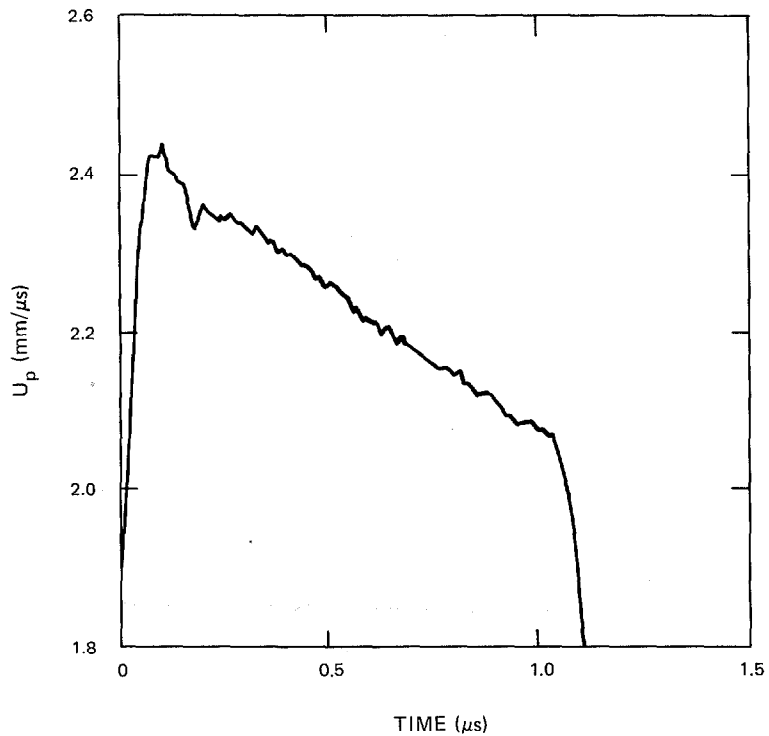

TARGET

Material: PBX 9404
Experiment type: ASM probe
Experimenter: W. C. Davis
Reference: Davis (1976)
Shot no.: F 3808 **Date:** September 3, 1975

HE SHOT GEOMETRY P-080 lens/101.6 mm PBX 9404/0.075 mm aluminum//
6.35 mm Teflon//

SHOT COMPONENTS PBX 9404
Density: 1.84 g/cm³
 $C_L = 2.90$ mm/ μ s $C_S = 1.57$ mm/ μ s
Teflon
Density: 2.14 g/cm³
 $C_L = 1.23$ mm/ μ s $C_S = 0.41$ mm/ μ s

TRANSDUCER

ASM probe
Coil radius: 18.62 mm Initial coil spacing: 6.78 mm

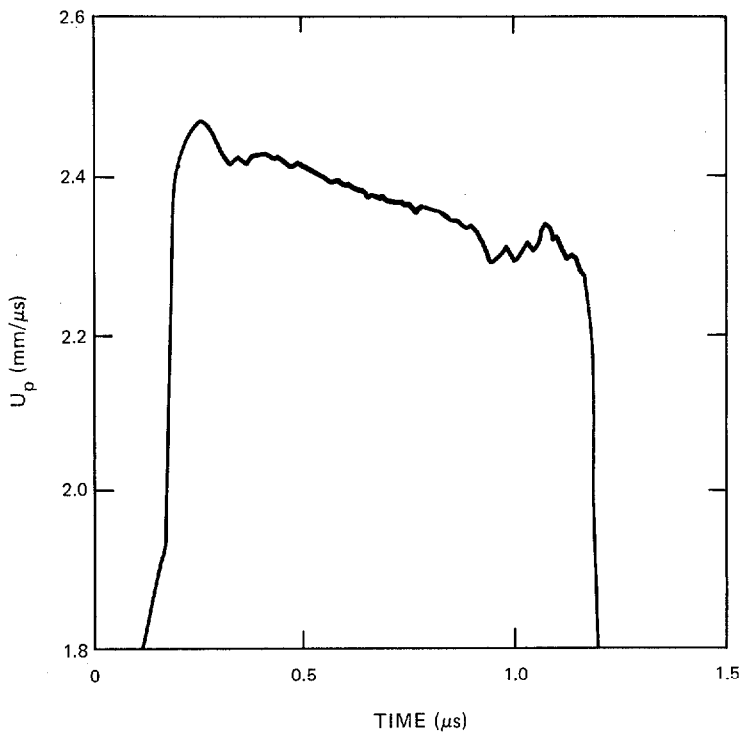

TARGET

Material: PBX 9404
Experiment type: ASM probe
Experimenter: W. C. Davis
Reference: Davis (1976)
Shot no.: F 3810 **Date:** September 3, 1975

HE SHOT GEOMETRY P-080 lens/50.8 mm PBX 9404/0.075 mm aluminum//
6.35 mm Teflon//

SHOT COMPONENTS

PBX 9404
Density: 1.84 g/cm³
 $C_L = 2.90$ mm/ μ s $C_S = 1.57$ mm/ μ s
Teflon
Density: 2.14 g/cm³
 $C_L = 1.23$ mm/ μ s $C_S = 0.41$ mm/ μ s

TRANSDUCER

ASM probe
Coil radius: 18.62 mm **Initial coil spacing:** 6.78 mm

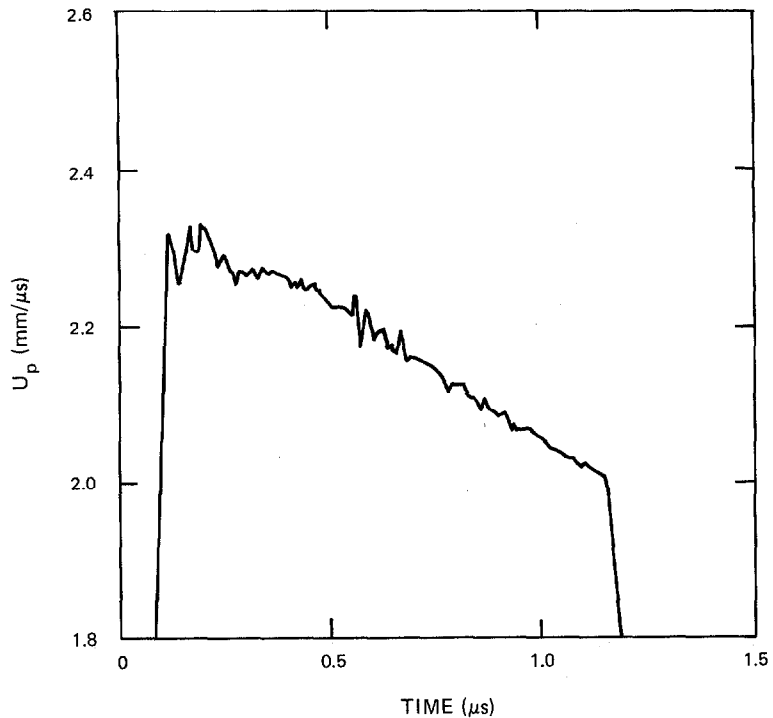

TARGET

Material: PBX 9404
Experiment type: ASM probe
Experimenter: W. C. Davis
Reference: Davis (1976)
Shot no.: F 3811 Date: September 3, 1975

HE SHOT GEOMETRY P-080 lens/203.2 mm PBX 9404/0.075 mm aluminum//
6.35 mm Teflon//

SHOT COMPONENTS PBX 9404
Density: 1.84 g/cm³
C_L = 2.90 mm/μs C_S = 1.57 mm/μs
Teflon
Density: 2.14 g/cm³
C_L = 1.23 mm/μs C_S = 0.41 mm/μs

TRANSDUCER ASM probe
Coil radius: 18.62 mm Initial coil spacing: 6.78 mm

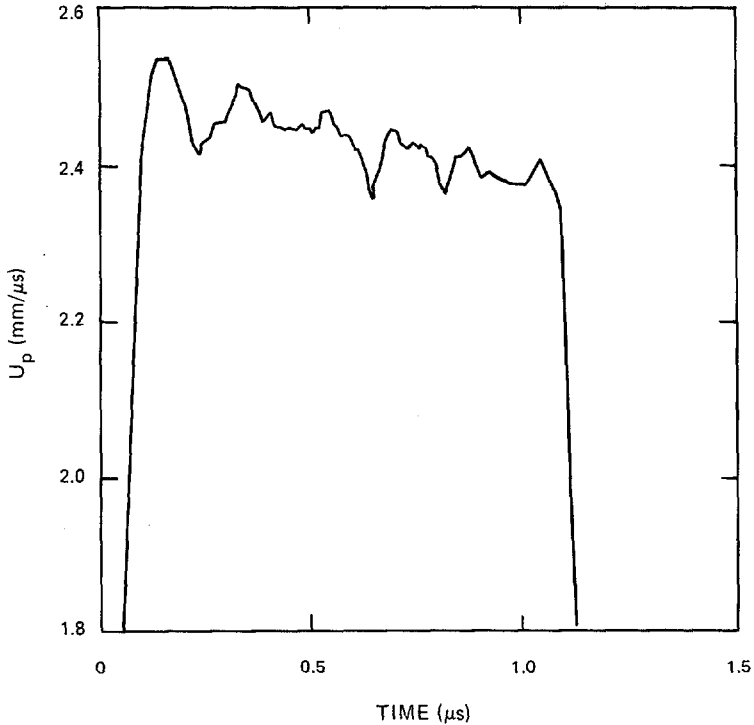

TARGET Material: PBX 9404 (plastic-bonded HMX)
Experiment type: Multiple embedded Manganin gage
Impact stress: 2.9 GPa
Experimenters: J. O. Johnson and Jerry Wackerle
Reference: Wackerle, Rabie, Ginsberg, and Anderson (1978)
Shot no.: 287 Series: M9404 Date: June 1976
Thickness: 15 mm Diameter: 65 mm
Density: 1.844 g/cm³
C_L = 2.96 mm/μs C_S = 1.57 mm/μs
Fabrication: Machined from material pressed from plastic-coated HMX

IMPACTOR Aluminum alloy projectile faced with copper, 8 mm thick
Impact velocity: 0.56 mm/μs

TRANSDUCER Two-terminal, 50-Ω Manganin gage
Locations from impact surface: 0.95 mm, 2.95 mm, 5.0 mm, and 7.0 mm
Encapsulation: 0.05-mm Kapton on each side
Reference: Wackerle, Johnson, and Halleck (1975a)
Time after impact

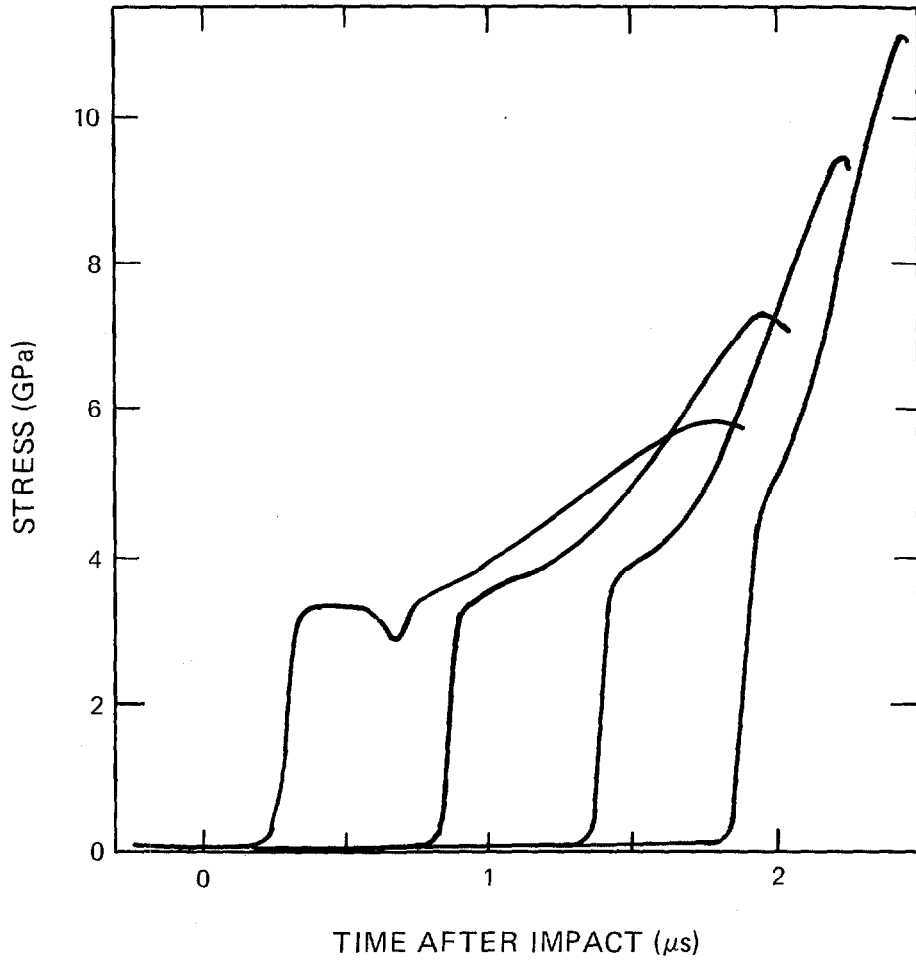

TARGET **Material:** PBX 9404
Experiment type: Multiple embedded Manganin gage
Impact stress: 2.9 GPa
Experimenters: J. O. Johnson and Jerry Wackerle
Reference: Wackerle, Rabie, Ginsberg, and Anderson (1978)
Shot no.: 288 **Series:** M9404 **Date:** June 1976
Thickness: 15 mm **Diameter:** 65 mm
Density: 1.844 g/cm³
C_L = 2.96 mm/μs **C_s** = 1.57 mm/μs
Fabrication: Machined from material pressed from plastic-coated HMX

IMPACTOR Aluminum alloy projectile faced with copper, 8 mm thick
Impact velocity: 0.56 mm/μs

TRANSDUCER Two-terminal, 50-Ω Manganin gage
Locations from impact surface: 2.4 mm, 4.5 mm, 6.5 mm, and 8.5 mm
Encapsulation: 0.05-mm Kapton on each side
Reference: Wackerle, Johnson, and Halleck (1975a)
Time after impact

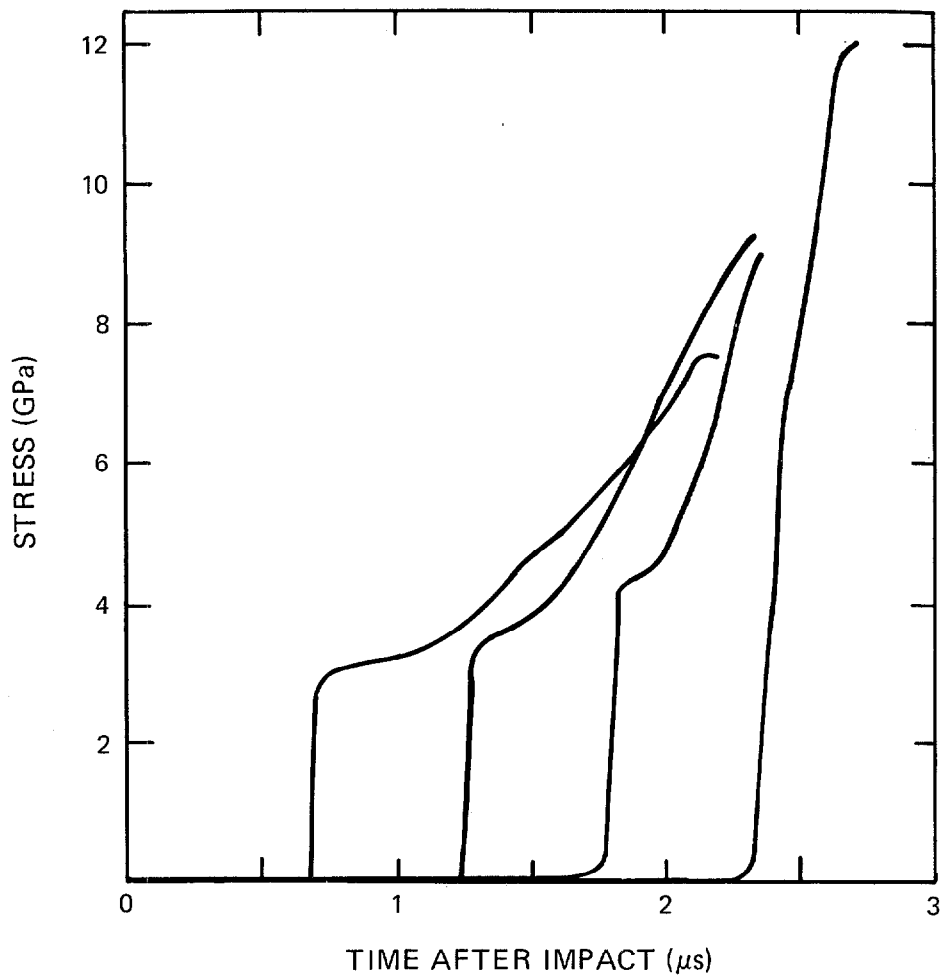

TARGET **Material:** PBX 9404
Experiment type: Multiple embedded Manganin gage
Impact stress: 2.9 GPa
Experimenters: J. O. Johnson and Jerry Wackerle
Reference: Wackerle, Rabie, Ginsberg, and Anderson (1978)
Shot no.: 290 **Series:** M9404 **Date:** July 7, 1976
Thickness: 15 mm **Diameter:** 65 mm
Density: 1.844 g/cm³
 $C_L = 2.96$ mm/ μ s $C_s = 1.57$ mm/ μ s
Fabrication: Machined from material pressed from plastic-coated HMX

IMPACTOR Aluminum alloy projectile faced with copper, 8 mm thick
Impact velocity: 0.553 mm/ μ s

TRANSDUCER *Two-terminal, 50- Ω Manganin gage*
Locations from impact surface: 2.01 mm, 3.99 mm, 5.99 mm, and 8.05 mm
Encapsulation: 0.05-mm Kapton on each side
Reference: Wackerle, Johnson, and Halleck (1975a)
Time after impact

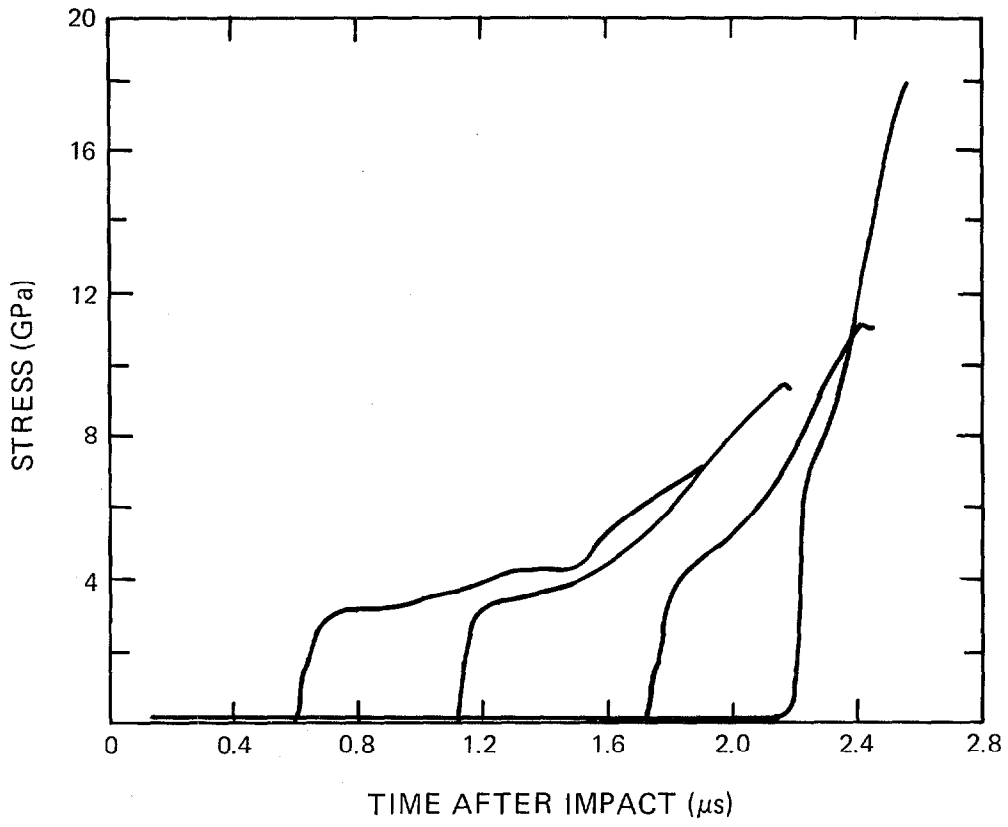

TARGET **Material:** PBX 9404
Experiment type: Multiple embedded Manganin gage
Impact stress: 2.9 GPa
Experimenters: J. O. Johnson and Jerry Wackerle
Reference: Wackerle, Rabie, Ginsberg, and Anderson (1978)
Shot no.: 292 **Series:** M9404 **Date:** July 13, 1976
Thickness: 15 mm **Diameter:** 65 mm
Density: 1.844 g/cm³
C_L = 2.96 mm/μs **C_s =** 1.57 mm/μs
Fabrication: Machined from material pressed from plastic-coated HMX

IMPACTOR Projectile faced with carbon foam and copper flyer, 1.0 mm thick
Impact velocity: 0.56 mm/μs

TRANSDUCER Two-terminal, 50-Ω Manganin gage
Locations from impact surface: 3.0 mm, 5.0 mm, and 7.0 mm
Encapsulation: 0.51-mm Kapton on each side
Reference: Wackerle, Johnson, and Halleck (1975a)
Time after impact

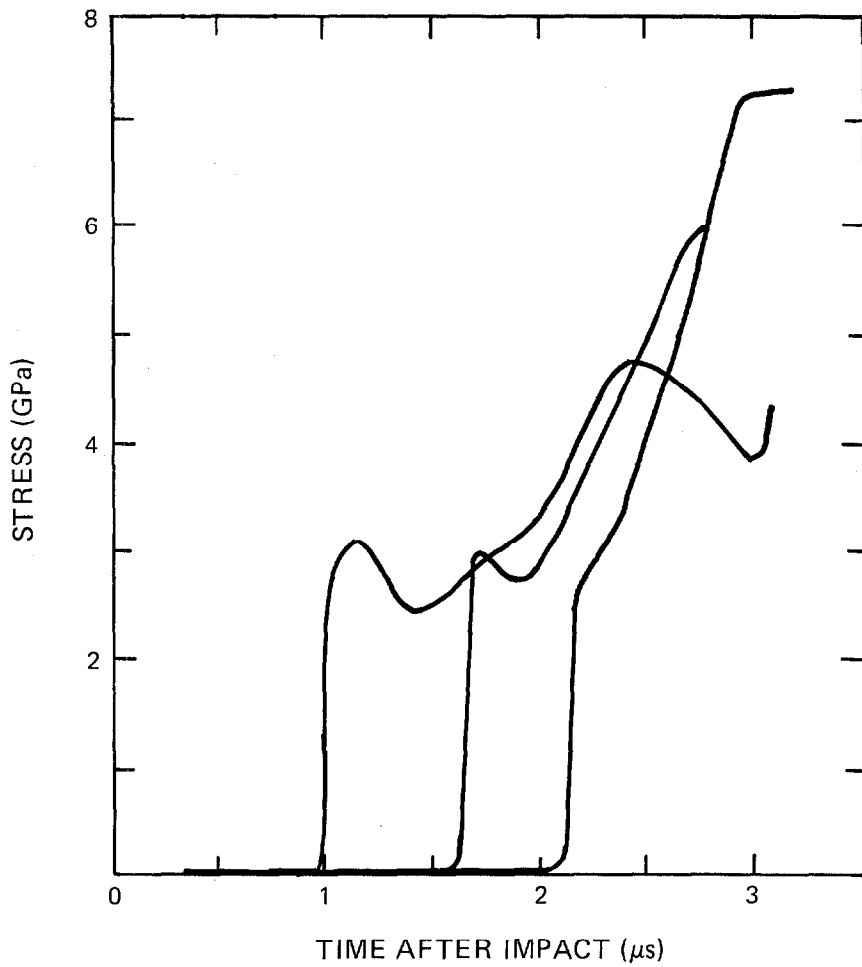

TARGET **Material:** PBX 9404
Experiment type: Multiple embedded Manganin gage
Impact stress: 2.9 GPa
Experimenters: J. O. Johnson and Jerry Wackerle
Reference: Wackerle, Rabie, Ginsberg, and Anderson (1978)
Shot no.: 294 **Series:** M9404 **Date:** July 23, 1976
Thickness: 15 mm **Diameter:** 65 mm
Density: 1.844 g/cm³
C_L = 2.96 mm/μs **C_s** = 1.57 mm/μs
Fabrication: Machined from material pressed from plastic-coated HMX

IMPACTOR Projectile faced with carbon foam and copper flyer, 0.76 mm thick
Impact velocity: 0.557 mm/μs

TRANSDUCER Two-terminal, 50-Ω Manganin gage
Locations from impact surface: 1.02 mm, 3.07 mm, 5.11 mm, and 7.16 mm
Encapsulation: 0.05-mm Kapton on each side
Reference: Wackerle, Johnson, and Halleck (1975a)
Time after impact

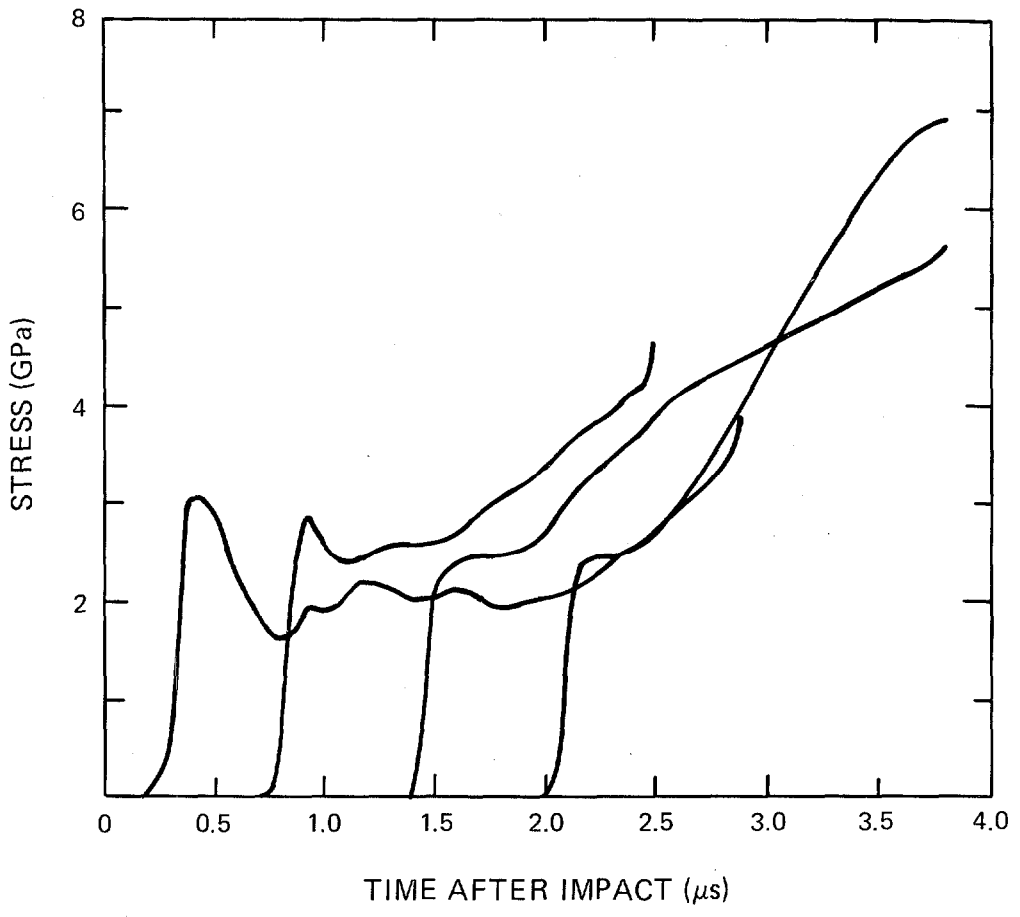

TARGET Material: PBX 9404
Experiment type: Multiple embedded Manganin gage
Impact stress: 2.9 GPa
Experimenters: J. O. Johnson and Jerry Wackerle
Reference: Wackerle, Rabie, Ginsberg, and Anderson (1978)
Shot no.: 295 Series: M9404 Date: August 10, 1976
Thickness: 15 mm Diameter: 65 mm
Density: 1.844 g/cm³
 $C_L = 2.96$ mm/ μ s $C_S = 1.57$ mm/ μ s
Fabrication: Machined from material pressed from plastic-coated HMX

IMPACTOR Projectile faced with carbon foam and copper flyer
Impact velocity: 0.55 mm/ μ s

TRANSDUCER Two-terminal, 50- Ω Manganin gage
Locations from impact surface: 1.0 mm, 3.1 mm, 5.1 mm, and 7.2 mm
Encapsulation: 0.05-mm Kapton on each side
Reference: Wackerle, Johnson, and Halleck (1975a)
Time after impact

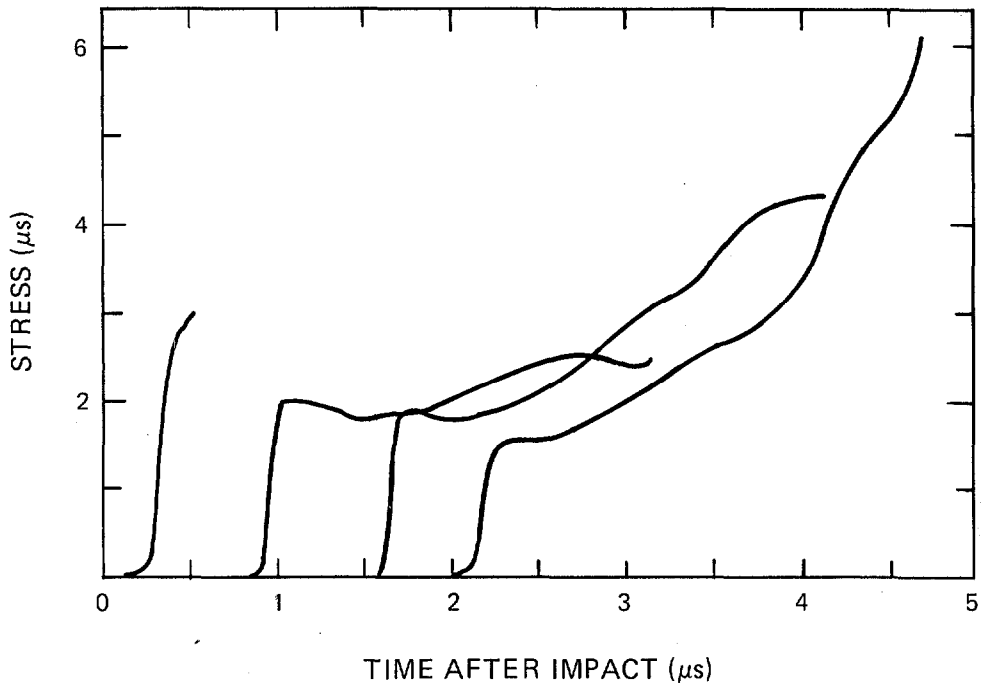

TARGET

Material: PBX 9404

Experiment type: Multiple embedded Manganin gage

Impact stress: 2.9 GPa

Experimenters: J. O. Johnson and Jerry Wackerle

Reference: Wackerle, Rabie, Ginsberg, and Anderson (1978)

Shot no.: 308 **Series:** M9404 **Date:** December 16, 1976

Thickness: 15 mm **Diameter:** 65 mm

Density: 1.844 g/cm³

$C_L = 2.96$ mm/ μ s $C_S = 1.57$ mm/ μ s

Fabrication: Machined from material pressed from plastic-coated HMX

IMPACTOR

Aluminum alloy faced with copper, 8 mm thick

Impact velocity: 0.556 mm/ μ s

TRANSDUCER

Two-terminal, 50- Ω Manganin gage

Locations from impact surface: 2.11 mm, 4.09 mm, and 6.12 mm

Encapsulation: 0.1-mm Kapton on each side

Reference: Wackerle, Johnson, and Halleck (1975a)

Time after impact

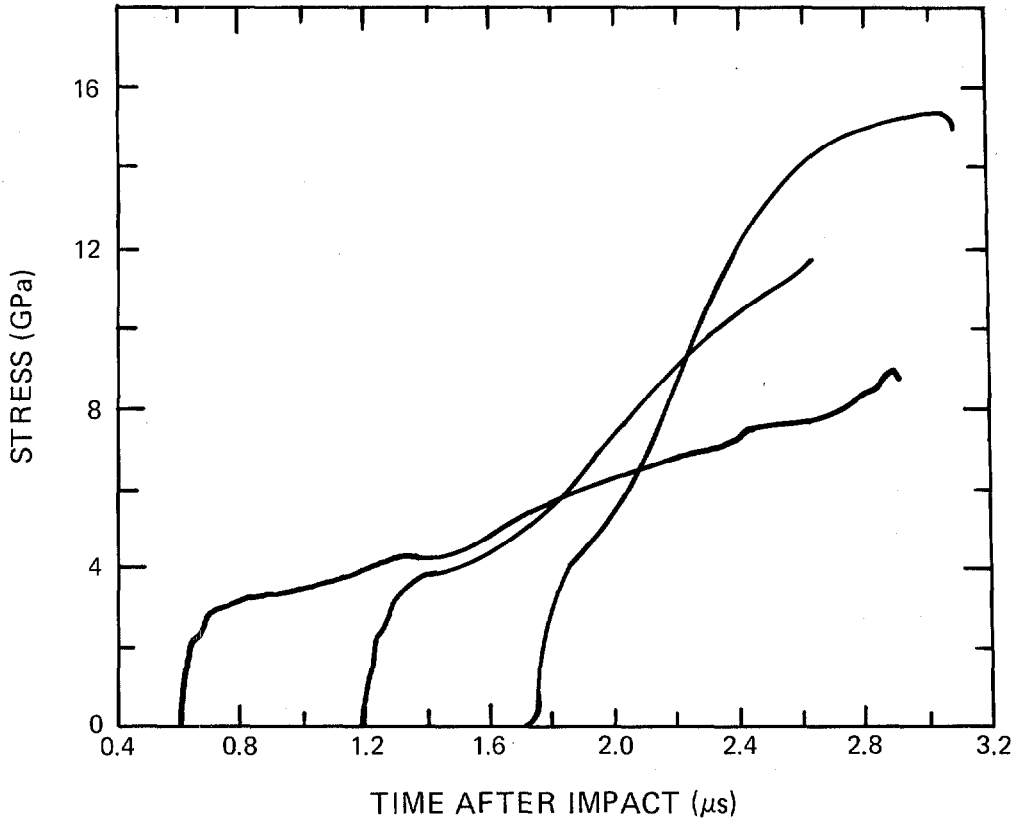

TARGET

Material: PBX 9404

Experiment type: Multiple embedded Manganin gage

Impact stress: 2.9 GPa

Experimenters: J. O. Johnson and Jerry Wackerle

Reference: Wackerle, Rabie, Ginsberg, and Anderson (1978)

Shot no.: 311 **Series:** M9404 **Date:** February 1, 1977

Thickness: 12 mm **Diameter:** 50 mm

Density: 1.844 g/cm³

$C_L = 2.96$ mm/ μ s $C_S = 1.57$ mm/ μ s

Fabrication: Machined from material pressed from plastic-coated HMX

IMPACTOR

Aluminum alloy projectile faced with copper, 8 mm thick

Impact velocity: 0.554 mm/ μ s

TRANSDUCER

Two-terminal, 50- Ω Manganin gage

Locations from impact surface: 2.69 mm, and 4.65 mm

Encapsulation: 0.1-mm Kapton on each side

Reference: Wackerle, Johnson, and Halleck (1975a)

Time after impact

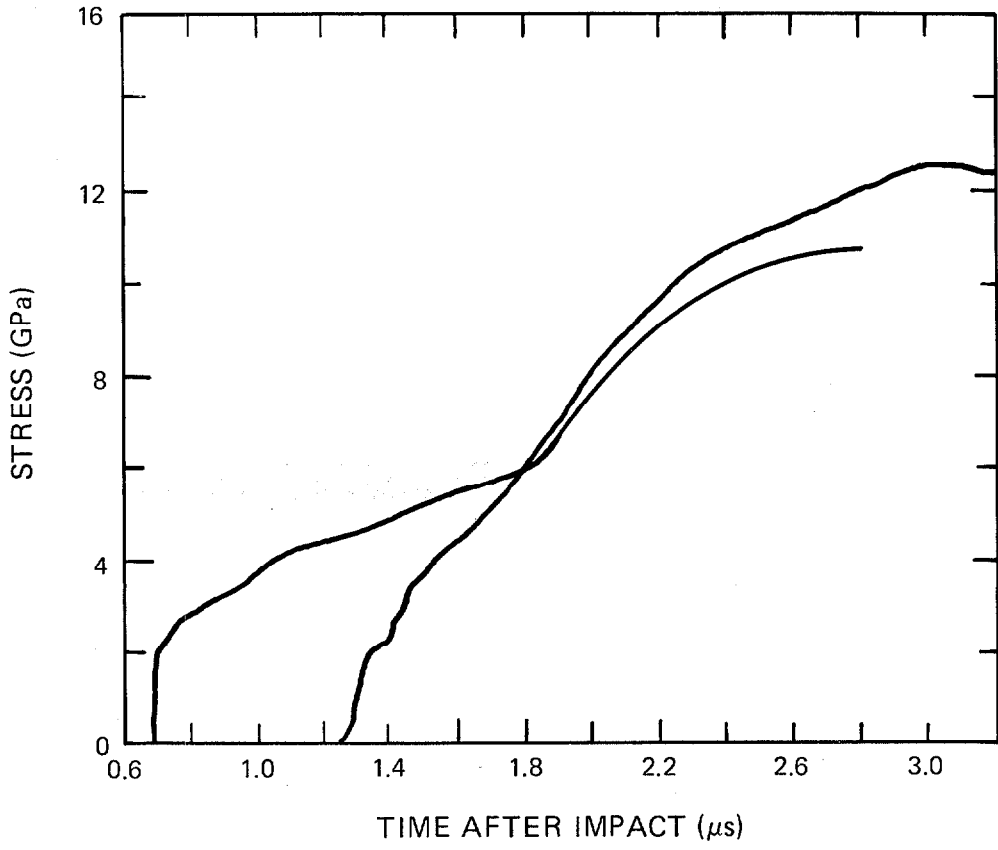

TARGET **Material:** PBX 9501, 95 wt% HMX/2.5 wt% Estane 5703 F1/2.5 wt% nitroplasticizer
Experiment type: Embedded Manganin gage
Experimenter: Bart Olinger
Shot no.: 56-77-103 **Date:** October 27, 1977
Diameter: 38.1 mm
Density: 1.82 g/cm³
C_L = 2.97 mm/μs **C_S** = 1.39 mm/μs

IMPACTOR PBX 9501, 3.05 mm thick, backed with low-density polyurethane foam, mounted on 51-mm-diam aluminum alloy projectile
Impact velocity: 0.248 mm/μs

TRANSDUCER Two-terminal, 50-Ω Manganin gage
Locations from impact surface: 2.04 mm, 6.11 mm, and 10.18 mm
Heat treatment: Annealed
Encapsulation: None
Calibration: J. W. Hopson and J. W. Taylor calibration formula for Manganin gages
 $\sigma = a_1 x + b_1 x^2 + c_1 x^3$ for $x < 0.1$,
 $\sigma = a_2 + b_2 x + c_2 x^2$ for $x > 0.1$,
where $x = \Delta R/R$.
a₁ = 521.32 **b₁** = -1614.86 **c₁** = 7648.72
a₂ = 6.5950 **b₂** = 370.37 **c₂** = 0.00
Time: Relative

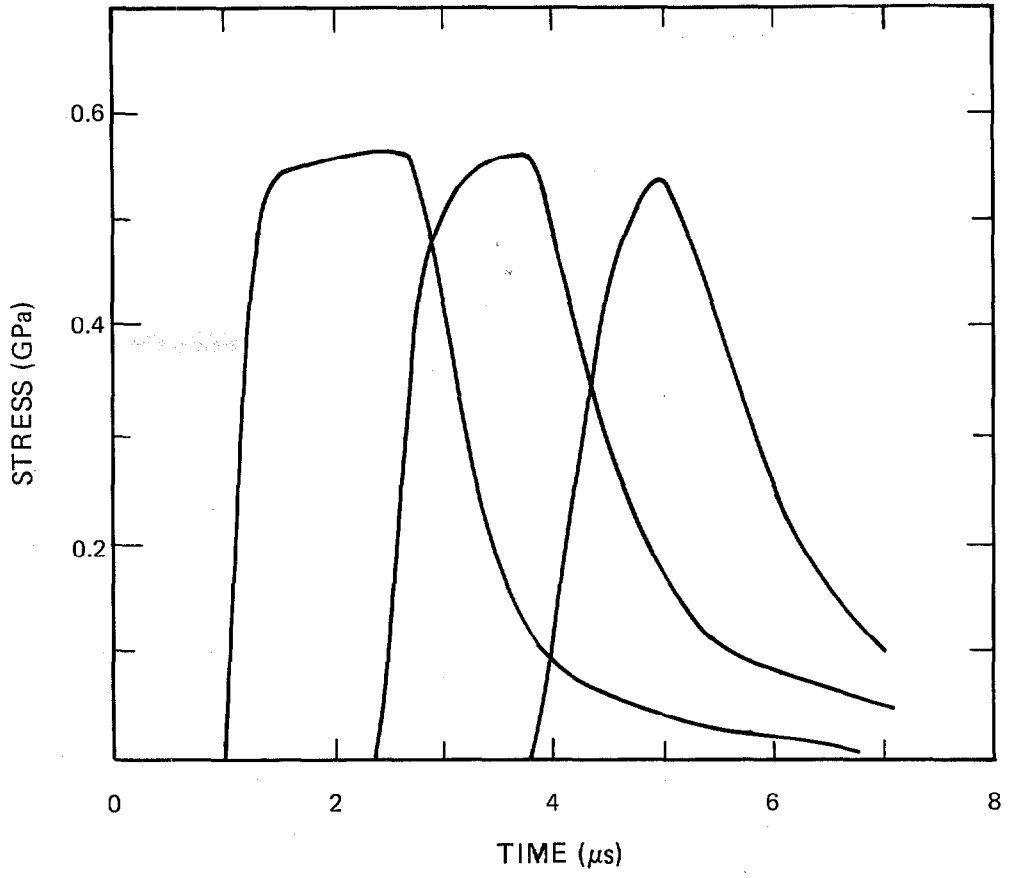

TARGET

Material: PBX 9502, 95 wt% TATB/5 wt% Kel-F 800

Experiment type: Embedded Manganin gage

Experimenter: Bart Olinger

Shot no.: 56-77-105 **Date:** October 27, 1977

Diameter: 38.1 mm

Density: 1.88 g/cm³

C_L = 2.74 mm/μs **C_S** = 1.41 mm/μs

IMPACTOR

PBX 9502, 3.05 mm thick, backed with low-density polyurethane foam, mounted on 51-mm-diam aluminum alloy projectile

Impact velocity: 0.252 mm/μs

TRANSDUCER

Two-terminal, 50-Ω Manganin gage

Locations from impact surface: 2.04 mm, 6.11 mm, and 10.18 mm

Heat treatment: Annealed

Encapsulation: None

Calibration: J. W. Hopson and J. W. Taylor calibration formula for Manganin gages

$\sigma = a_1 x + b_1 x^2 + c_1 x^3$ for $x < 0.1$,

$\sigma = a_2 + b_2 x + c_2 x^2$ for $x > 0.1$,

where $x = \Delta R/R$.

$a_1 = 521.32$ $b_1 = -1614.86$ $c_1 = 7648.72$

$a_2 = 6.5950$ $b_2 = 370.37$ $c_2 = 0.00$

Time: Relative

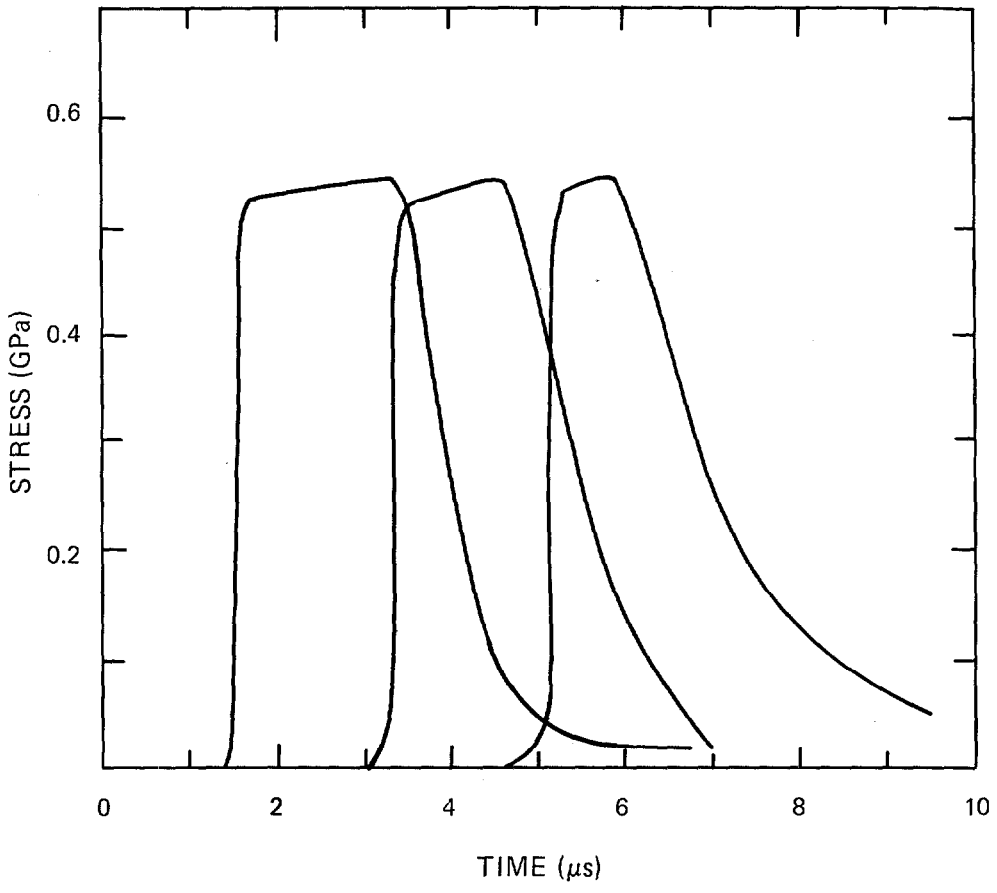

TARGET

Material: Pressed PETN

Experiment type: Manganin gage impact face

Impact stress: 0.9 GPa

Experimenters: P. M. Halleck, J. O. Johnson, and Jerry Wackerle

References: Wackerle, Johnson, and Halleck (1975a), (1975b)

Shot no.: 241 **Series:** LDPM **Date:** January 15, 1975

Thickness: 3 mm **Diameter:** 62 mm

Density: 1.40 g/cm³

Fabrication: Specimen was dry-pressed from permeametric specific surface 3000-cm²/g detonator-grade PETN and was machined into disks

IMPACTOR

7075 Aluminum or brass projectile faced with explosive specimen

Impact velocity: 0.406 mm/ μ s

TRANSDUCERS

Two-terminal, 50- Ω Manganin gage

Locations from impact surface: 0 mm, 0 mm, 0 mm, and 0 mm

Encapsulation: 0.05-mm Kapton on each side

Reference: Wackerle, Johnson, and Halleck (1975a)

Time after impact

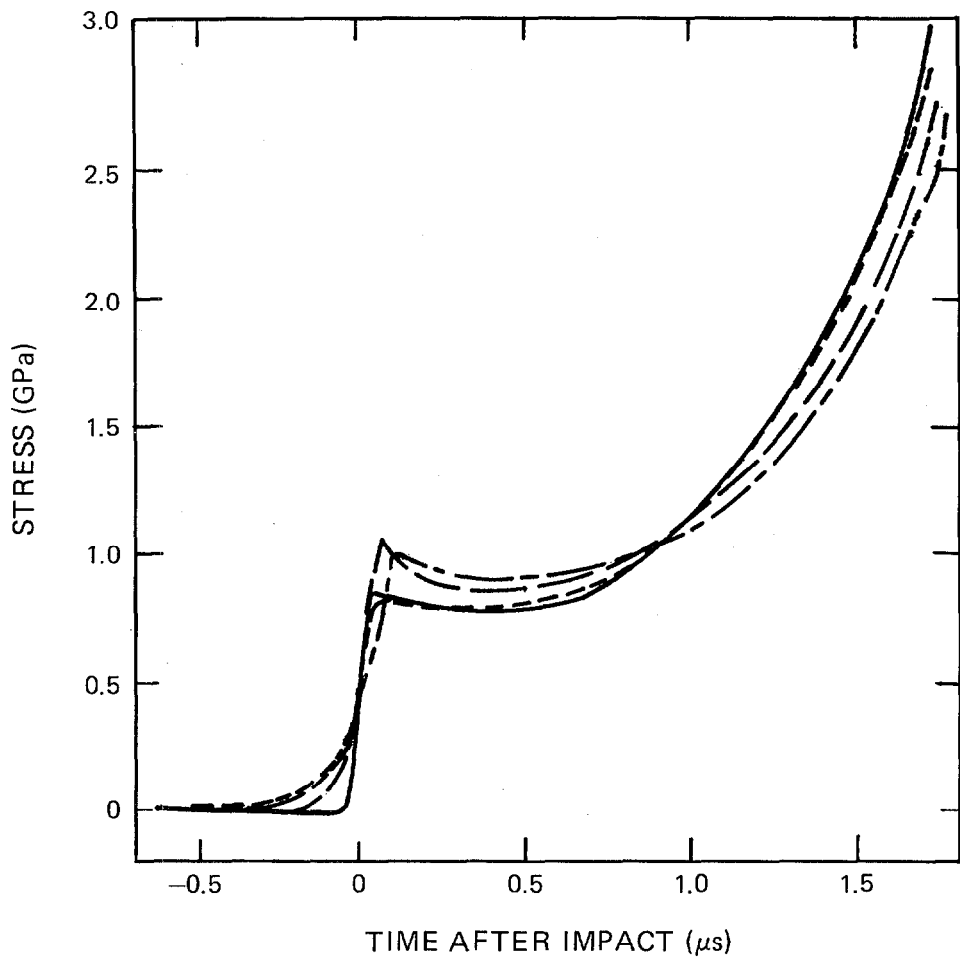

TARGET **Material:** Pressed PETN
Experiment type: Multiple embedded Manganin gage
Impact stress: 1.9 GPa
Experimenters: Jerry Wackerle, J. O. Johnson, and P. M. Halleck
References: Wackerle, Johnson, and Halleck (1975a), (1976)
Shot no.: 183 **Series:** HDPM **Date:** March 2, 1974
Thickness: 5.5 mm **Diameter:** 38 mm
Density: 1.75 g/cm³
C_L = 2.98 mm/μs **C_s** = 1.64 mm/μs

IMPACTOR 7075 Aluminum alloy projectile
Impact velocity: 0.476 mm/μs

TRANSDUCERS Two-terminal, 50-Ω Manganin gage
Locations from impact surface: 2.1 mm and 3.2 mm
Encapsulation: 0.05-mm Kapton on each side
Reference: Wackerle, Johnson, and Halleck (1975a)
Time: Relative

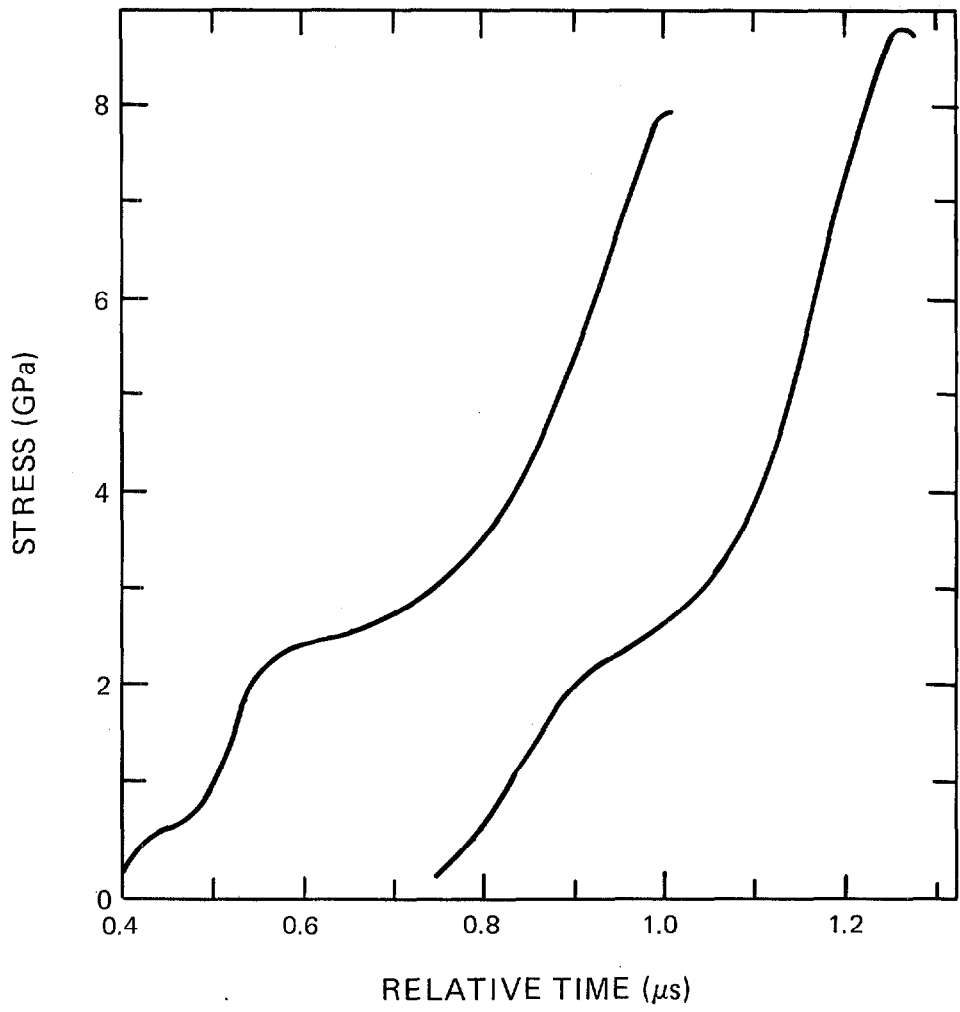

TARGET **Material:** Pressed PETN
Experiment type: Multiple embedded Manganin gage
Impact stress: 0.5 GPa
Experimenters: P. M. Halleck, J. O. Johnson, and Jerry Wackerle
References: Wackerle, Johnson, and Halleck (1975a), (1975b)
Shot no.: 255 **Series:** LDPM **Date:** June 5, 1975
Thickness: 10 mm **Diameter:** 41 mm
Density: 1.40 g/cm³
Fabrication: Specimen was dry-pressed from permeametric specific surface 3000-cm²/g detonator-grade PETN and was machined into disks

IMPACTOR 7075 Aluminum alloy projectile
Impact velocity: 0.29 mm/μs

TRANSDUCERS Two-terminal, 50-Ω Manganin gage
Locations from impact surface: 2 mm, 4 mm, 6 mm, and 8 mm
Encapsulation: 0.05-mm Kapton on each side
Reference: Wackerle, Johnson, and Halleck (1975a)
Time after impact

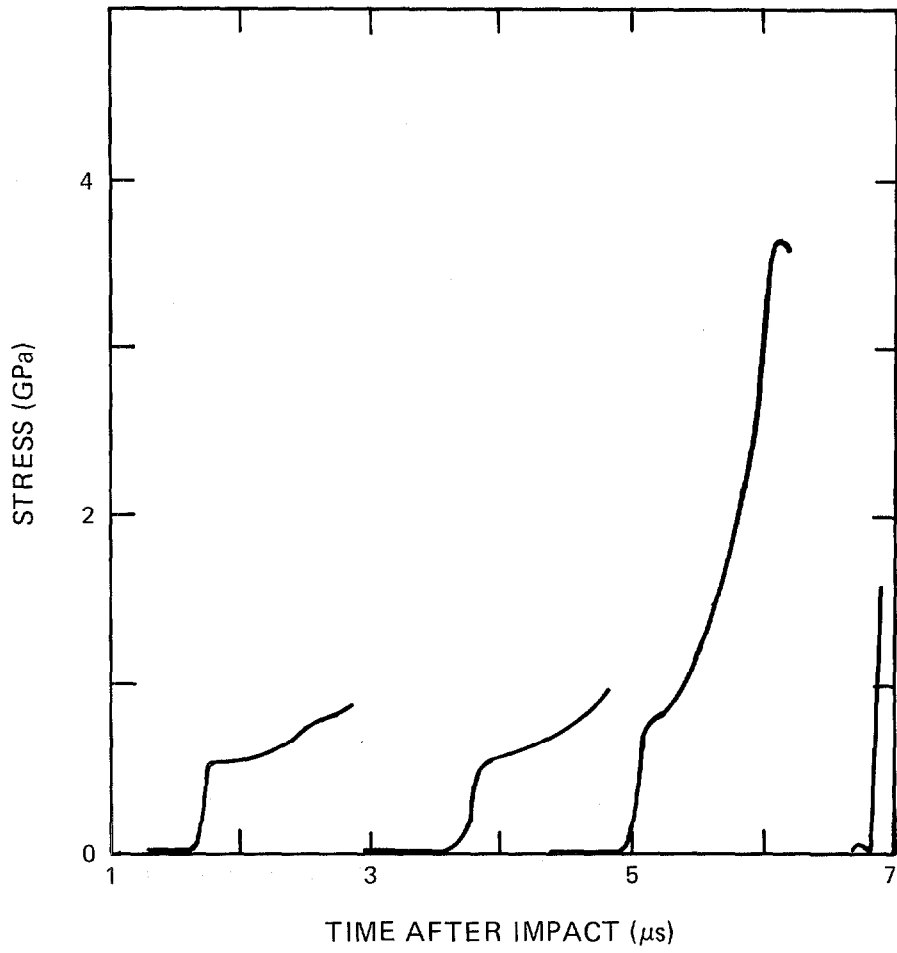

TARGET

Material: Pressed PETN
Experiment type: Multiple embedded Manganin gage
Impact stress: 0.5 GPa
Experimenters: P. M. Halleck, J. O. Johnson, and Jerry Wackerle
References: Wackerle, Johnson, and Halleck (1975a), (1975b)
Shot no.: 256 **Series:** LDPM **Date:** June 10, 1975
Thickness: 9 mm **Diameter:** 41 mm
Density: 1.40 g/cm³
Fabrication: Specimen was dry-pressed from permeametric specific surface 3000-cm²/g detonator-grade PETN and was machined into disks

IMPACTOR

7075 Aluminum alloy projectile
Impact velocity: 0.489 mm/ μ s

TRANSDUCERS

Two-terminal, 50- Ω Manganin gage
Locations from impact surface: 1 mm, 3 mm, 5 mm, and 7 mm
Encapsulation: 0.05-mm Kapton on each side
Reference: Wackerle, Johnson, and Halleck (1975a)
Time after impact

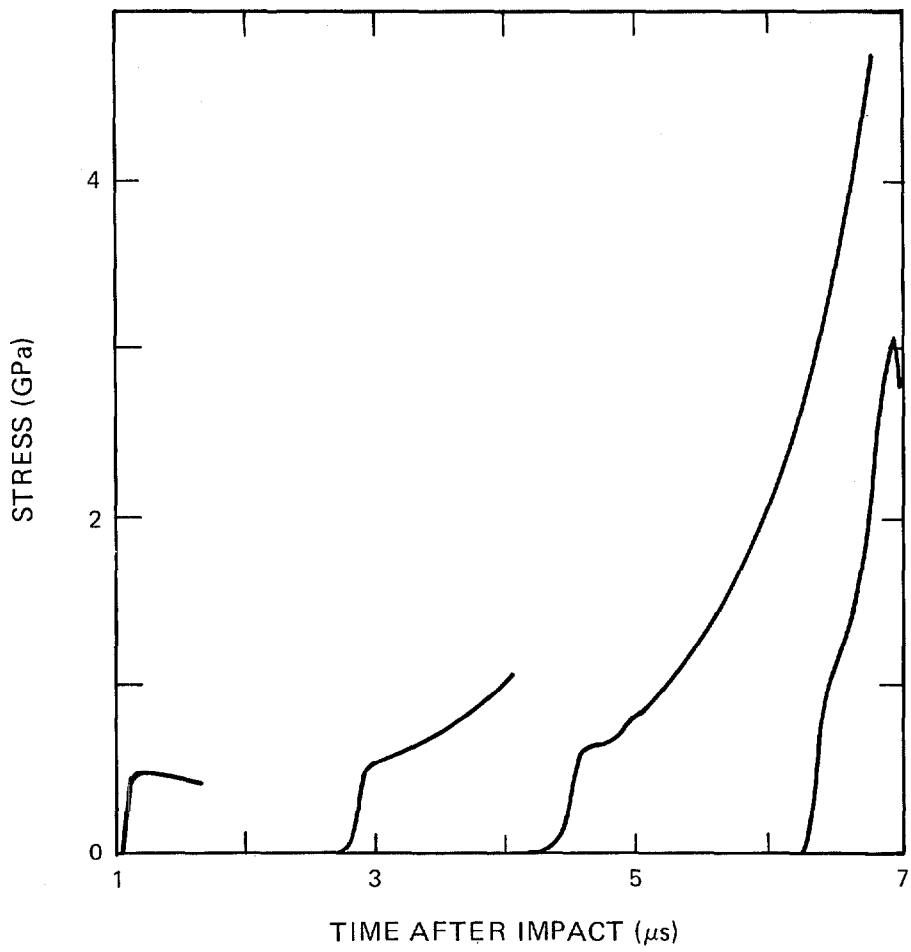

TARGET**Material:** Pressed PETN**Experiment type:** Multiple embedded Manganin gage**Impact stress:** 2 GPa**Experimenters:** Jerry Wackerle, J. O. Johnson, and P. M. Halleck**References:** Wackerle, Johnson, and Halleck (1975a), (1976)**Shot no.:** 283 **Series:** HDPM **Date:** April 13, 1976**Thickness:** 6.8 mm **Diameter:** 37 mm**Density:** 1.75 g/cm³ $C_L = 2.98 \text{ mm}/\mu\text{s}$ $C_s = 1.64 \text{ mm}/\mu\text{s}$ **Fabrication:** Specimen was dry-pressed from permeametric specific surface 3000-cm²/g detonator-grade PETN and was machined into disks**IMPACTOR****7075 Aluminum alloy projectile****Impact velocity:** 0.479 mm/ μs **TRANSDUCERS****Two-terminal, 50- Ω Manganin gage****Locations from impact surface:** 1.58 mm, 2.67 mm, 3.79 mm, and 4.87 mm**Encapsulation:** 0.05-mm Kapton on each side**Reference:** Wackerle, Johnson, and Halleck (1975a)**Time:** Relative

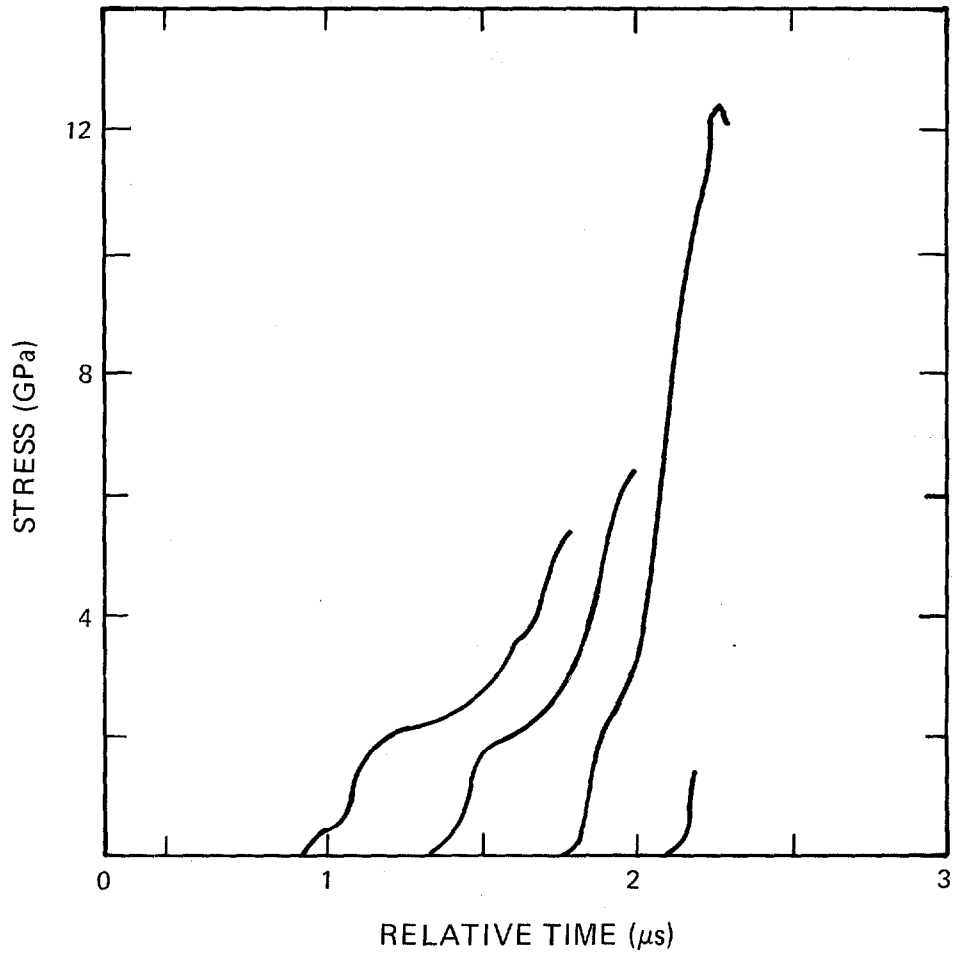

TARGET

Material: Pressed PETN
Experiment type: Quartz-gage front back
Impact stress: 1.0 GPa
Experimenters: Jerry Wackerle and J. O. Johnson
Reference: Wackerle and Johnson (1973)
Shot no.: 6-3 **Series no.:** X67 **Date:** 1969
Thickness: 1.23 mm **Diameter:** 33 mm
Density: 1.58 g/cm³
Fabrication: Specimens were dry-pressed at ambient temperature from permeametric specific surface 3000-cm²/g detonator-grade PETN

IMPACTOR

50-mm-diam aluminum alloy projectile faced with quartz gage described below
Impact velocity: 0.37 mm/ μ s

TRANSDUCERS

Impact face: Shunted guard-ring quartz gage
30-mm diam by 7.3 mm thick; 9.4-mm-diam electrode
Back face: Shunted guard-ring quartz gage
22-mm diam by 4.8 mm thick; 9.4-mm-diam electrode
Reference: Graham, Neilson, and Benedick (1965)
Time after impact

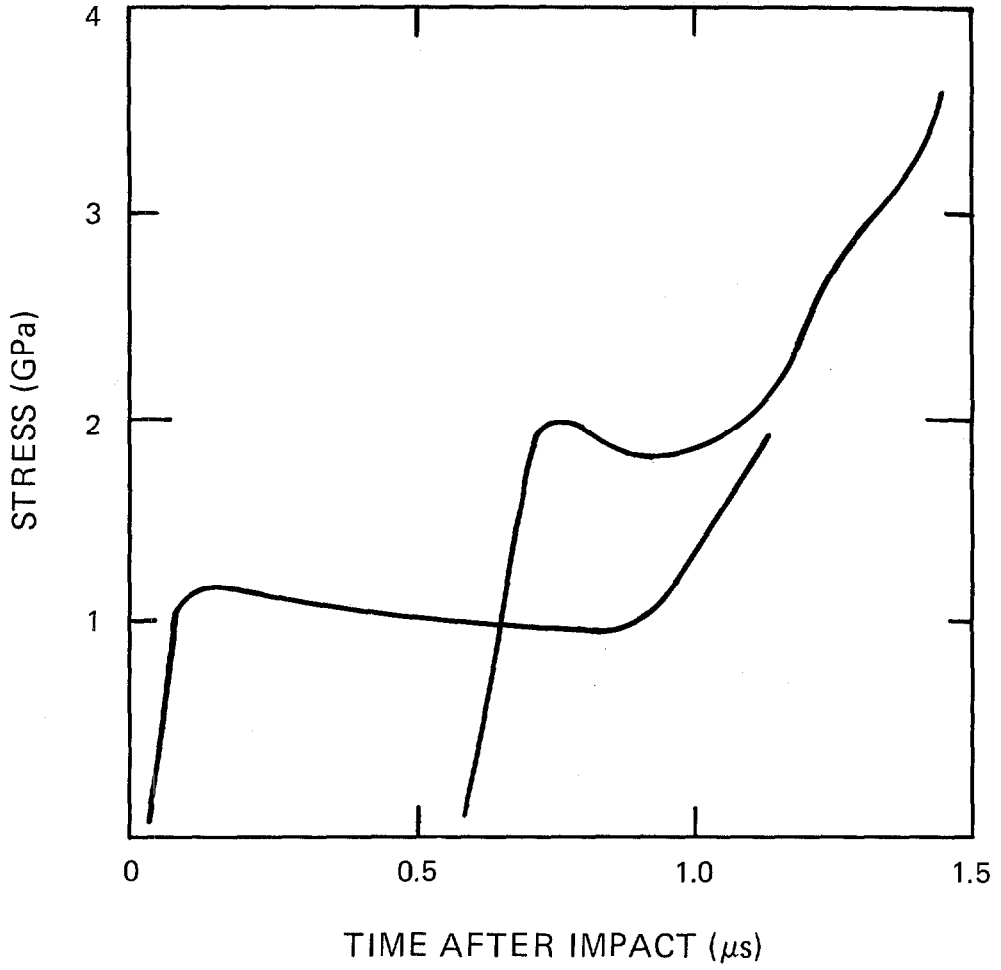

TARGET

Material: Pressed PETN
Experiment type: Quartz-gage front back
Impact stress: 1.04 GPa
Experimenters: Jerry Wackerle and J. O. Johnson
Reference: Wackerle and Johnson (1973)
Shot no.: 6-4 **Series no.:** X67 **Date:** 1969
Thickness: 4.23 mm **Diameter:** 33 mm
Density: 1.59 g/cm³
Fabrication: Specimens were dry-pressed at ambient temperature from permeametric specific surface 3000-cm²/g detonator-grade PETN

IMPACTOR

50-mm-diam aluminum alloy projectile faced with quartz gage described below
Impact velocity: 0.375 mm/ μ s

TRANSDUCERS

Impact face: Shunted guard-ring quartz gage
30-mm diam by 7.3 mm thick; 9.4-mm-diam electrode
Back face: Shunted guard-ring quartz gage
22-mm diam by 4.8 mm thick; 9.4-mm-diam electrode
Reference: Graham, Neilson, and Benedick (1965)
Time after impact

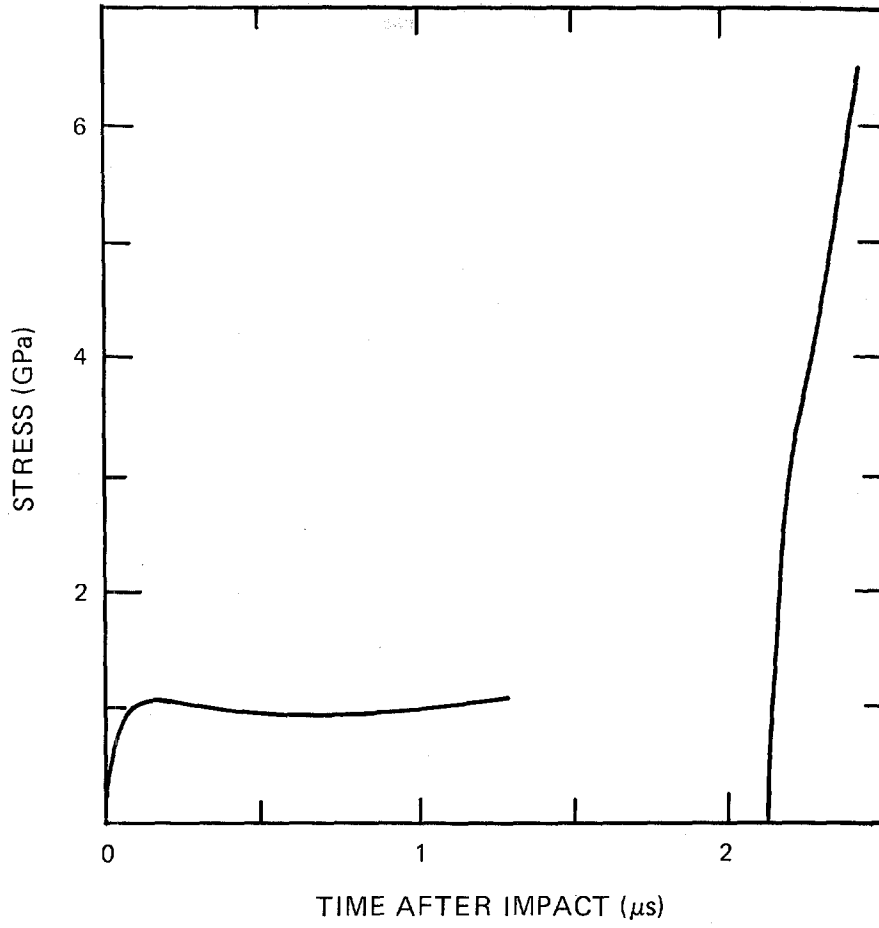

TARGET**Material:** Pressed PETN**Experiment type:** Quartz-gage front back**Impact stress:** 1.50 GPa**Experimenters:** Jerry Wackerle and J. O. Johnson**Reference:** Wackerle and Johnson (1973)**Shot no.:** 7-2 **Series no.:** X67 **Date:** 1969**Thickness:** 4.45 mm **Diameter:** 33 mm**Density:** 1.71 g/cm³**C_L =** 2.9 mm/μs **C_s =** 1.5 mm/μs**Fabrication:** Specimens were dry-pressed at ambient temperature from permeametric specific surface 3000-cm²/g detonator-grade PETN**IMPACTOR**

50-mm-diam aluminum alloy projectile faced with quartz gage described below

Impact velocity: 0.398 mm/μs**TRANSDUCERS****Impact face:** Shunted guard-ring quartz gage

30-mm diam by 7.3 mm thick; 9.4-mm-diam electrode

Back face: Shunted guard-ring quartz gage

22-mm diam by 4.8 mm thick; 9.4-mm-diam electrode

Reference: Graham, Neilson, and Benedick (1965)**Time after impact**

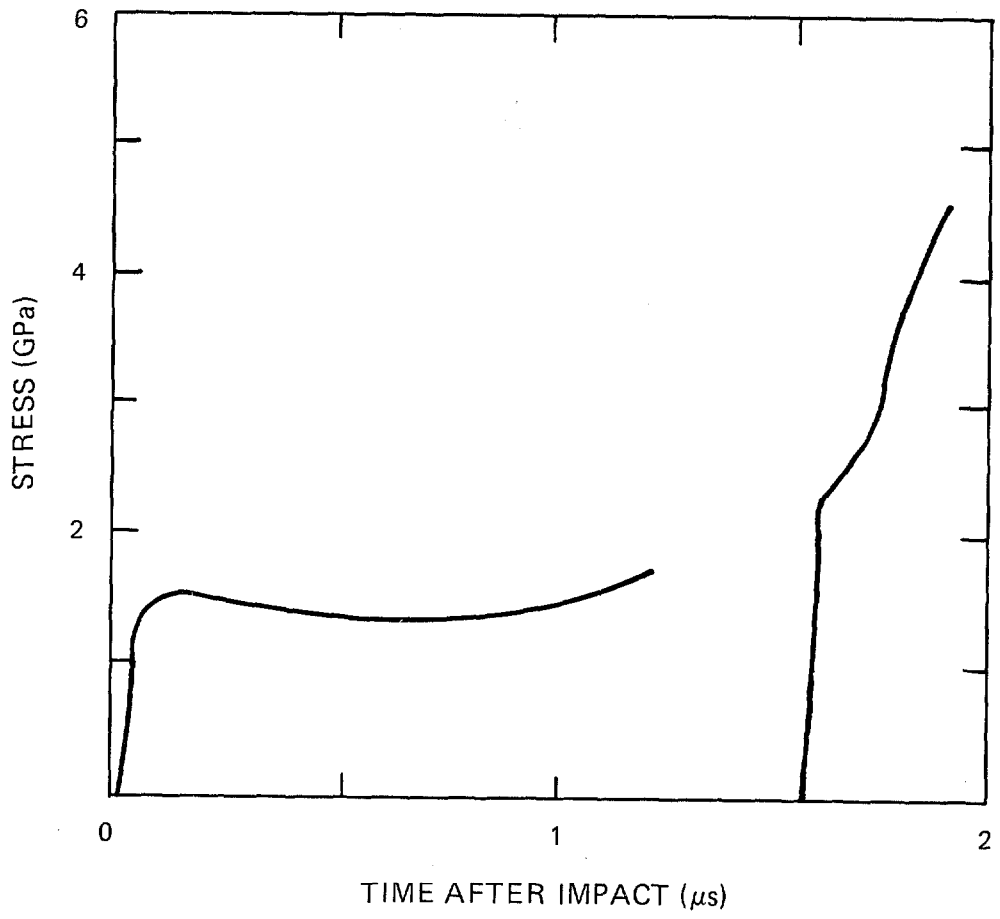

TARGET

Material: Pressed PETN

Experiment type: Quartz-gage front back

Impact stress: 1.68 GPa

Experimenters: Jerry Wackerle and J. O. Johnson

Reference: Wackerle and Johnson (1973)

Shot no.: 7-3 **Series no.:** X67 **Date:** 1969

Thickness: 4.45 mm **Diameter:** 33 mm

Density: 1.72 g/cm³

$C_L = 2.93$ mm/ μ s $C_s = 1.55$ mm/ μ s

Fabrication: Specimens were dry-pressed at ambient temperature from permeametric specific surface 3000-cm²/g detonator-grade PETN

IMPACTOR

50-mm-diam aluminum alloy projectile faced with quartz gage described below

Impact velocity: 0.429 mm/ μ s

TRANSDUCERS

Impact face: Shunted guard-ring quartz gage

30-mm diam by 7.3 mm thick; 9.4-mm-diam electrode

Back face: Shunted guard-ring quartz gage

22-mm diam by 4.8 mm thick; 9.4-mm-diam electrode

Reference: Graham, Neilson, and Benedick (1965)

Time after impact

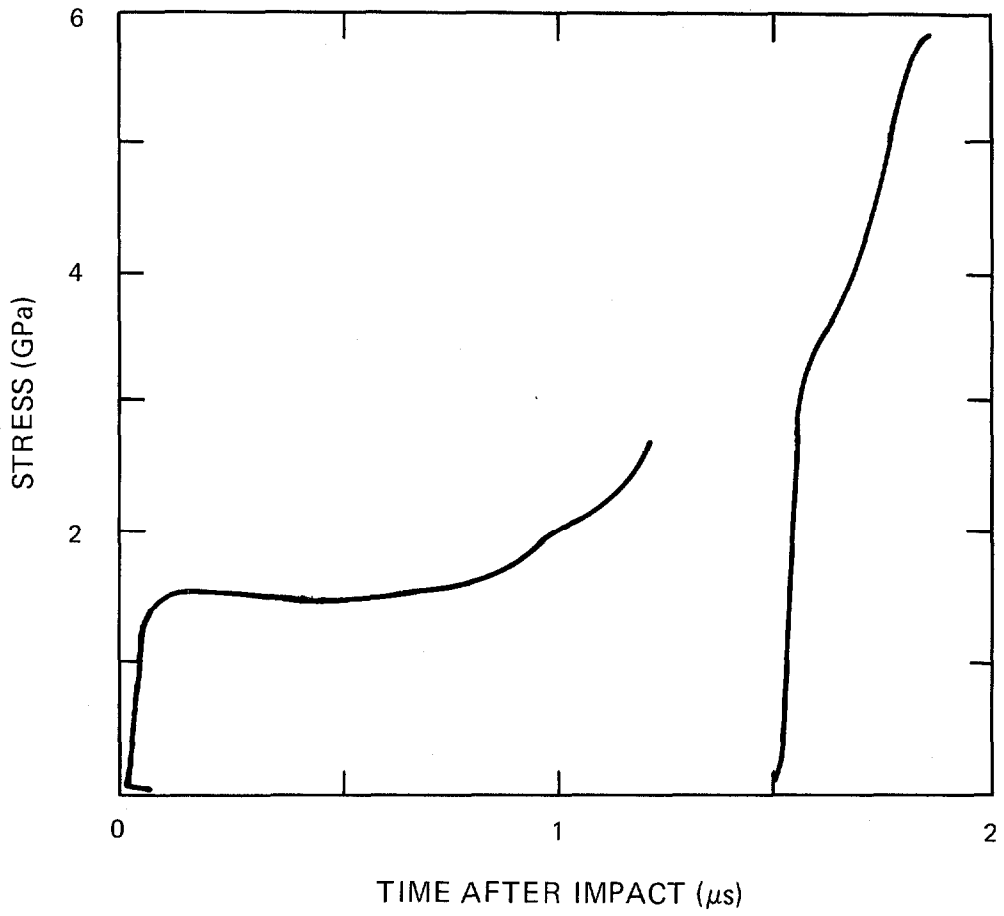

TARGET

Material: Pressed PETN

Experiment type: Quartz-gage front back

Impact stress: 1.67 GPa

Experimenters: Jerry Wackerle and J. O. Johnson

Reference: Wackerle and Johnson (1973)

Shot no.: 7-7 **Series no.:** X67 **Date:** 1969

Thickness: 1.22 mm **Diameter:** 33 mm

Density: 1.70 g/cm³

$C_L = 2.9$ mm/ μ s $C_S = 1.5$ mm/ μ s

Fabrication: Specimens were dry-pressed at ambient temperature from permeametric specific surface 3000-cm²/g detonator-grade PETN

IMPACTOR

50-mm-diam aluminum alloy projectile faced with quartz gage described below

Impact velocity: 0.444 mm/ μ s

TRANSDUCERS

Impact face: Shunted guard-ring quartz gage

30-mm diam by 7.3 mm thick; 9.4-mm-diam electrode

Back face: Shunted guard-ring quartz gage

22-mm diam by 4.8 mm thick; 9.4-mm-diam electrode

Reference: Graham, Neilson, and Benedick (1965)

Time after impact

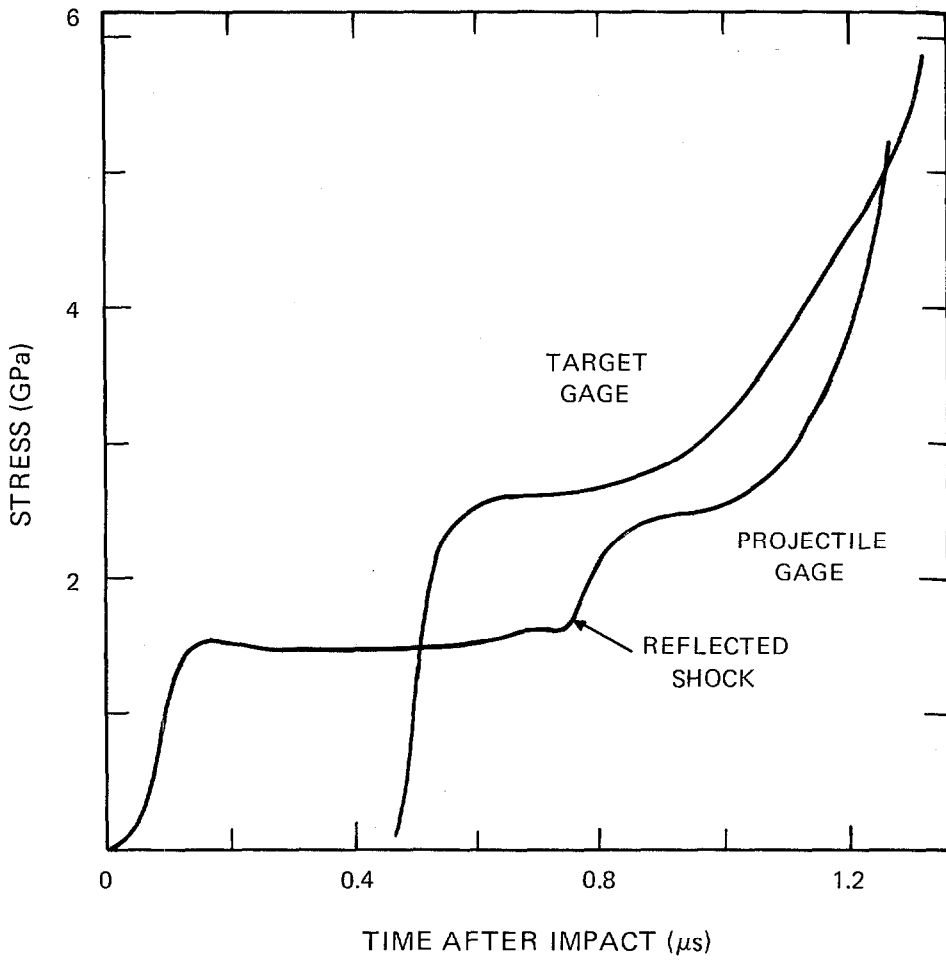

TARGET **Material:** Pressed PETN
Experiment type: Quartz-gage front back
Impact stress: 1.63 GPa
Experimenters: Jerry Wackerle and J. O. Johnson
Reference: Wackerle and Johnson (1973)
Shot no.: 7-8 **Series no.:** X67 **Date:** 1969
Thickness: 1.91 mm **Diameter:** 33 mm
Density: 1.71 g/cm³
 $C_L = 2.9$ mm/ μ s $C_s = 1.5$ mm/ μ s
Fabrication: Specimens were dry-pressed at ambient temperature from permeametric specific surface 3000-cm²/g detonator-grade PETN

IMPACTOR 50-mm-diam aluminum alloy projectile faced with quartz gage described below
Impact velocity: 0.444 mm/ μ s

TRANSDUCERS **Impact face:** Shunted guard-ring quartz gage
30-mm diam by 7.3 mm thick; 9.4-mm-diam electrode
Back face: Shunted guard-ring quartz gage
22-mm diam by 4.8 mm thick; 9.4-mm-diam electrode
Reference: Graham, Neilson, and Benedick (1965)
Time after impact

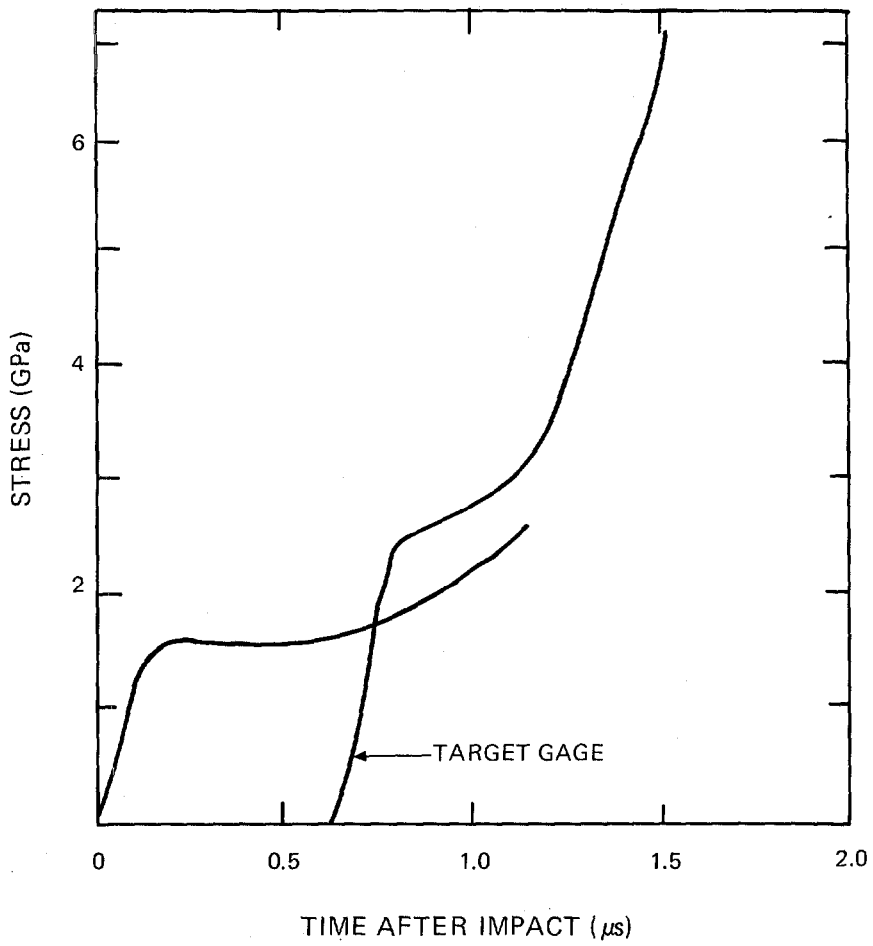

TARGET

Material: Pressed PETN
Experiment type: Quartz-gage front back
Impact stress: 1.63 GPa
Experimenters: Jerry Wackerle and J. O. Johnson
Reference: Wackerle and Johnson (1973)
Shot no.: 7-9 **Series no.:** X67 **Date:** 1969
Thickness: 3.95 mm **Diameter:** 33 mm
Density: 1.6 g/cm³
 $C_L = 2.9$ mm/ μ s $C_S = 1.5$ mm/ μ s
Fabrication: Specimens were dry-pressed at ambient temperature from permeametric specific surface 3000-cm²/g detonator-grade PETN

IMPACTOR

50-mm-diam aluminum alloy projectile faced with quartz gage described below
Impact velocity: 0.444 mm/ μ s

TRANSDUCERS

Impact face: Shunted guard-ring quartz gage
30-mm diam by 7.3 mm thick; 9.4-mm-diam electrode
Back face: Shunted guard-ring quartz gage
22-mm diam by 4.8 mm thick; 9.4-mm-diam electrode
Reference: Graham, Neilson, and Benedick (1965)
Time after impact

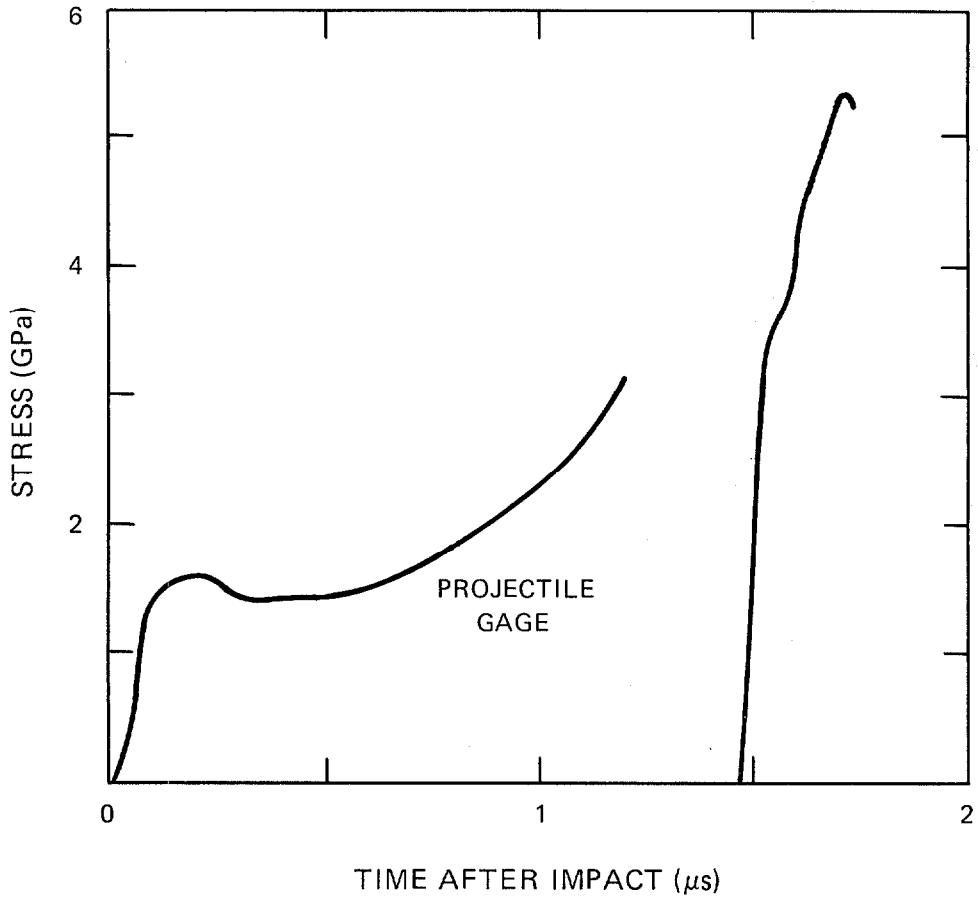

TARGET

Material: Pressed PETN

Experiment type: Quartz-gage front back

Impact stress: 1.75 GPa

Experimenters: Jerry Wackerle and J. O. Johnson

Reference: Wackerle and Johnson (1973)

Shot no.: 7-10 **Series no.:** X67 **Date:** 1969

Thickness: 1.23 mm **Diameter:** 33 mm

Density: 1.71 g/cm³

$C_L = 2.9$ mm/ μ s $C_S = 1.5$ mm/ μ s

Fabrication: Specimens were dry-pressed at ambient temperature from permeametric specific surface 3000-cm²/g detonator-grade PETN with an 0.82-mm Lucite buffer layer included between the explosive sample and the target gage

IMPACTOR

50-mm-diam aluminum alloy projectile faced with quartz gage described below

Impact velocity: 0.453 mm/ μ s

TRANSDUCERS

Impact face: Shunted guard-ring quartz gage

30-mm diam by 7.3 mm thick; 9.4-mm-diam electrode

Back face: Shunted guard-ring quartz gage

22-mm diam by 4.8 mm thick; 9.4-mm-diam electrode

Reference: Graham, Neilson, and Benedick (1965)

Time after impact

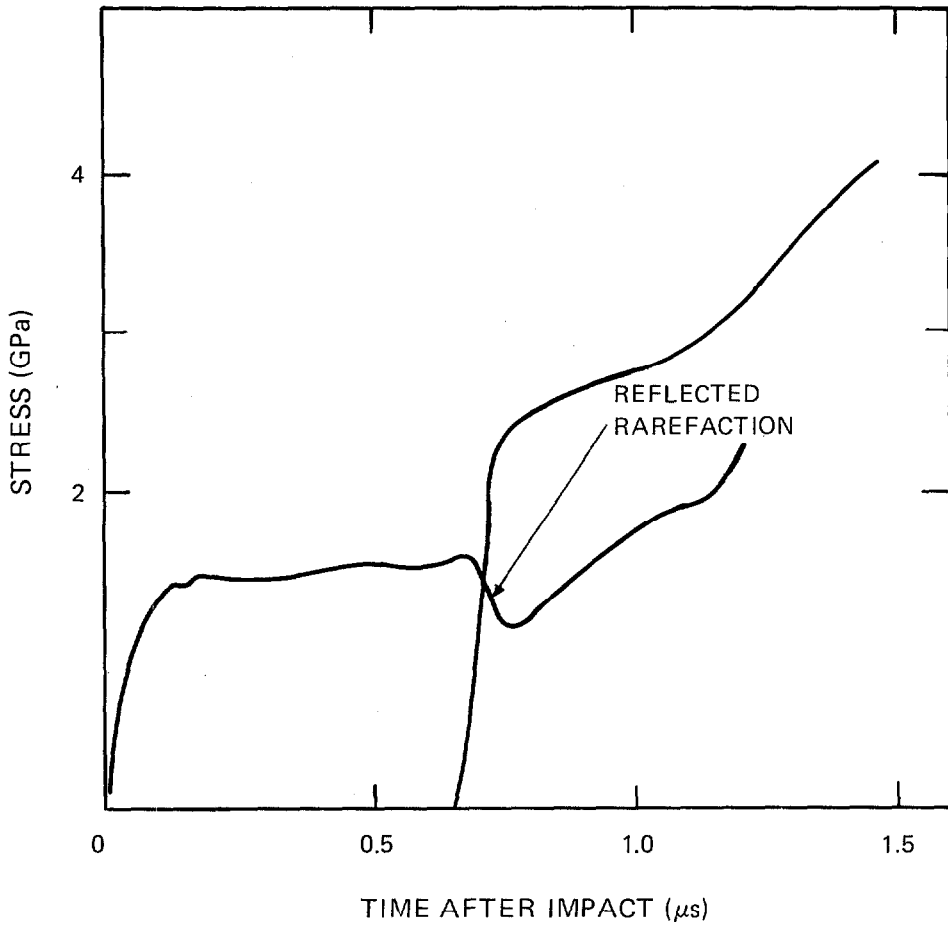

TARGET

Material: Pressed PETN
Experiment type: Quartz-gage front back
Impact stress: 1.6 GPa
Experimenters: Jerry Wackerle, P. M. Halleck, and J. O. Johnson
References: Wackerle, Johnson, and Halleck (1975a), (1976)
Shot no.: 26 **Series no.:** HDPQ
Date: November 19, 1971
Thickness: 5.11 mm **Diameter:** 40 mm
Density: 1.7 g/cm³
C_L = 2.98 mm/μs **C_S** = 1.64 mm/μs
Fabrication: Specimens were dry-pressed from permeametric specific surface 3000-cm²/g detonator-grade PETN and were machined into disks

IMPACTOR

Aluminum alloy projectile faced with impact-face gage described below
Impact velocity: 0.38 mm/μs

TRANSDUCERS

Impact face: Grounded guard-ring quartz gage
30-mm diam by 9.2 mm thick; 9.6-mm-diam electrode
Back face: Grounded guard-ring quartz gage
28-mm diam by 9.2 mm thick; 9.6-mm-diam electrode
Calibration: Wackerle, with field-fringe correction
Reference: Wackerle, Johnson, and Halleck (1975a)
Time after impact

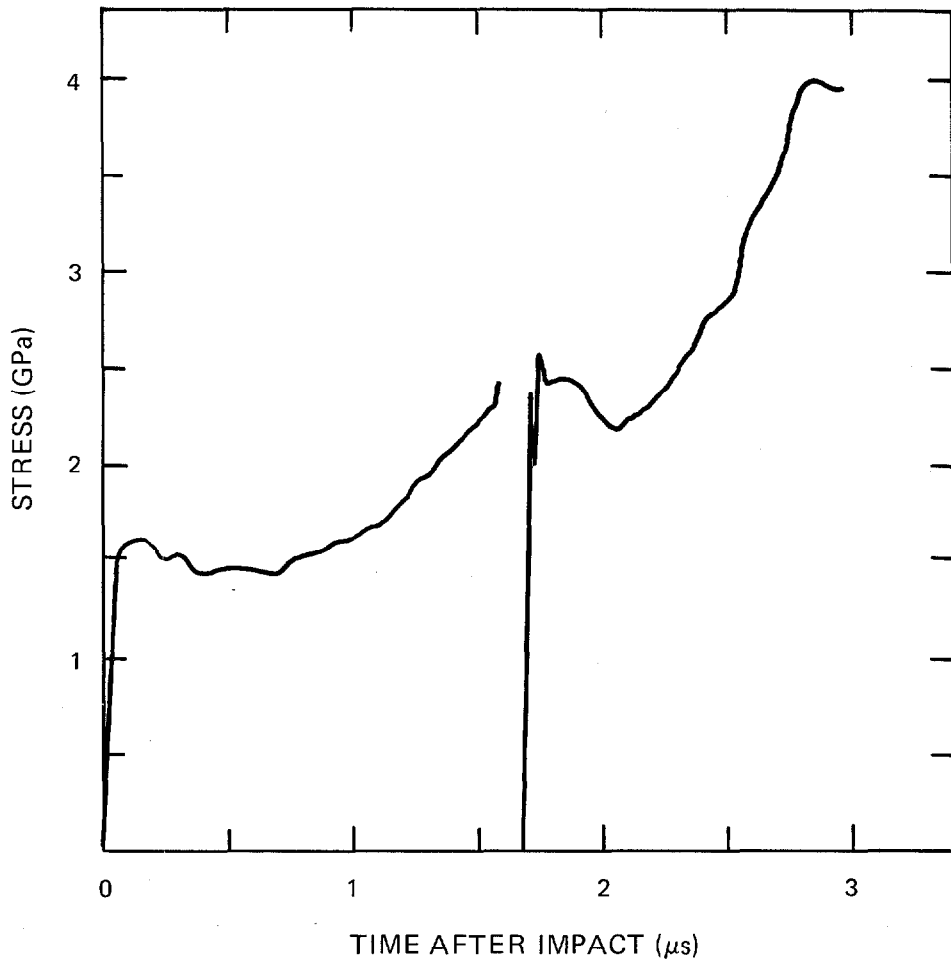

TARGET **Material:** Pressed PETN
Experiment type: Quartz-gage front back
Impact stress: 1.8 GPa
Experimenters: Jerry Wackerle, P. M. Halleck, and J. O. Johnson
References: Wackerle, Johnson, and Halleck (1975a), (1976)
Shot no.: 28 **Series no.:** HDPQ
Date: December 13, 1971
Thickness: 2.0 mm **Diameter:** 40 mm
Density: 1.7 g/cm³
C_L = 2.98 mm/μs **C_s =** 1.64 mm/μs
Fabrication: Specimens were dry-pressed from permeametric specific surface 3000-cm²/g detonator-grade PETN and were machined into disks

IMPACTOR Aluminum alloy projectile faced with impact-face gage described below
Impact velocity: 0.56 mm/μs

TRANSDUCERS **Impact face:** Grounded guard-ring quartz gage
30-mm diam by 9.2 mm thick; 9.6-mm-diam electrode
Back face: Grounded guard-ring quartz gage
23-mm diam by 9.2 mm thick; 9.6-mm-diam electrode
Calibration: Wackerle, with field-fringe correction
Reference: Wackerle, Johnson, and Halleck (1975a)
Time after impact

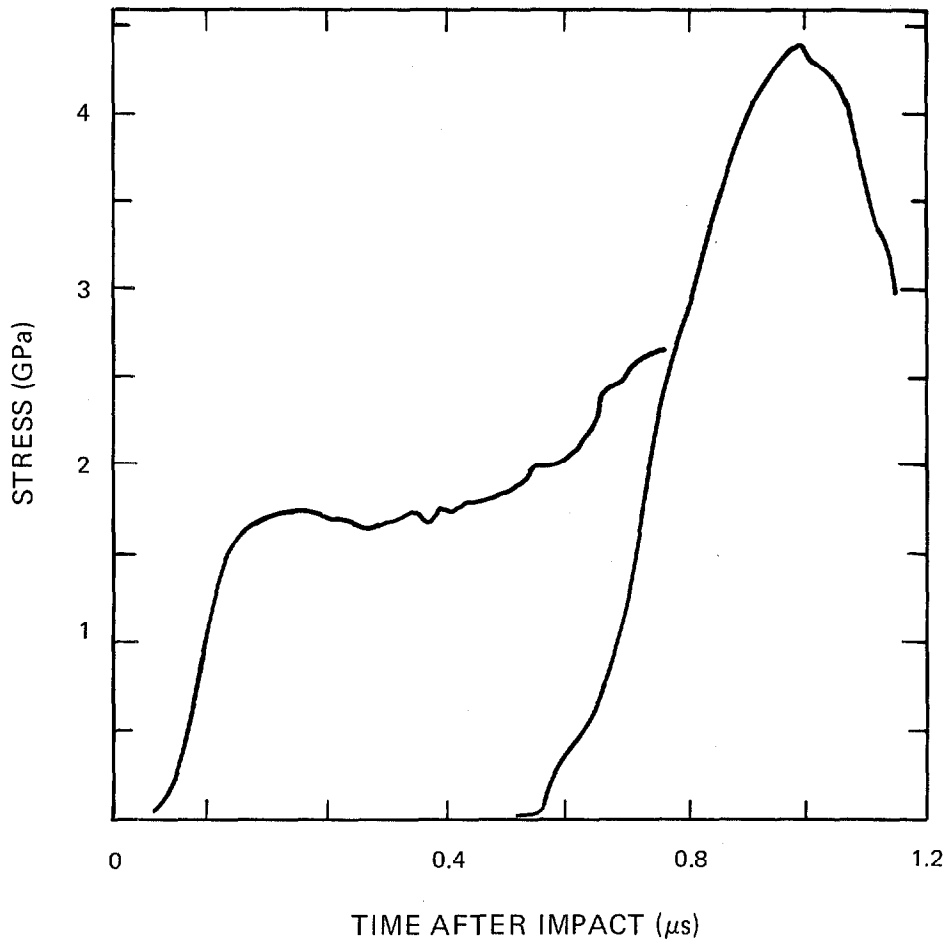

TARGET **Material:** Pressed PETN
Experiment type: Quartz-gage front back
Impact stress: 0.72 GPa
Experimenters: Jerry Wackerle, P. M. Halleck, and J. O. Johnson
References: Wackerle, Johnson, and Halleck (1975a), (1976)
Shot no.: 29 **Series no.:** HDPQ
Date: December 15, 1971
Thickness: 8.1 mm **Diameter:** 40 mm
Density: 1.750 g/cm³
C_L = 2.98 mm/μs **C_s** = 1.64 mm/μs
Fabrication: Specimens were dry-pressed from permeametric specific surface 3000-cm²/g detonator-grade PETN and were machined into disks

IMPACTOR Aluminum alloy projectile faced with impact-face gage described below
Impact velocity: 0.202 mm/μs

TRANSDUCERS **Impact face:** Grounded guard-ring quartz gage
30-mm diam by 9.2 mm thick; 9.6-mm-diam electrode
Back face: Grounded guard-ring quartz gage
23-mm diam by 9.2 mm thick; 9.6-mm-diam electrode
Calibration: Wackerle, with field-fringe correction
Reference: Wackerle, Johnson, and Halleck (1975a)
Time after impact

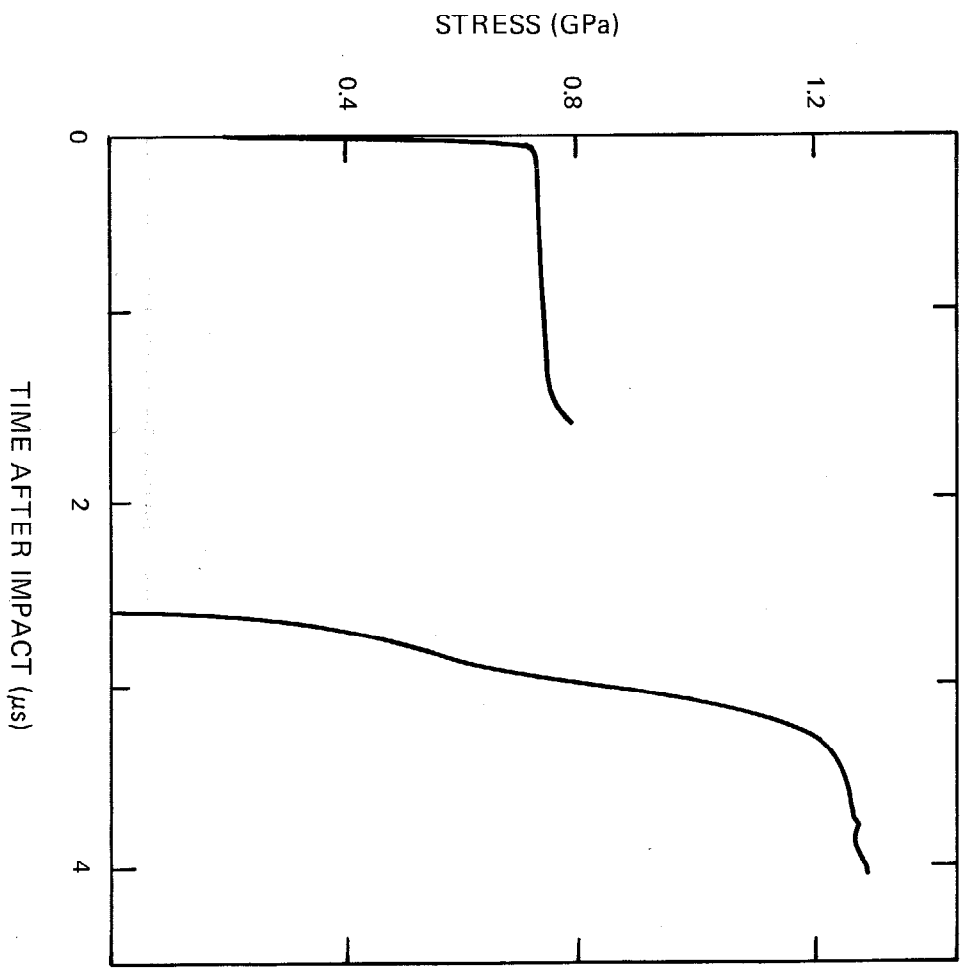

TARGET**Material:** Pressed PETN**Experiment type:** Quartz-gage front back**Impact stress:** 0.46 GPa**Experimenters:** Jerry Wackerle, P. M. Halleck, and J. O. Johnson**References:** Wackerle, Johnson, and Halleck (1975a), (1976)**Shot no.:** 30 **Series no.:** HDPQ**Date:** December 17, 1971**Thickness:** 8.11 mm **Diameter:** 40 mm**Density:** 1.752 g/cm³ $C_L = 2.98 \text{ mm}/\mu\text{s}$ $C_s = 1.64 \text{ mm}/\mu\text{s}$ **Fabrication:** Specimens were dry-pressed from permeametric specific surface 3000-cm²/g detonator-grade PETN and were machined into disks**IMPACTOR**

Aluminum alloy projectile faced with impact-face gage described below

Impact velocity: 0.121 mm/ μs **TRANSDUCER****Impact face:** Grounded guard-ring quartz gage

33-mm diam by 9.2 mm thick; 9.6-mm-diam electrode

Back face: Grounded guard-ring quartz gage

23-mm diam by 9.2 mm thick; 9.6-mm-diam electrode

Calibration: Wackerle, with field-fringe correction**Reference:** Wackerle, Johnson, and Halleck (1975a)**Time after impact**

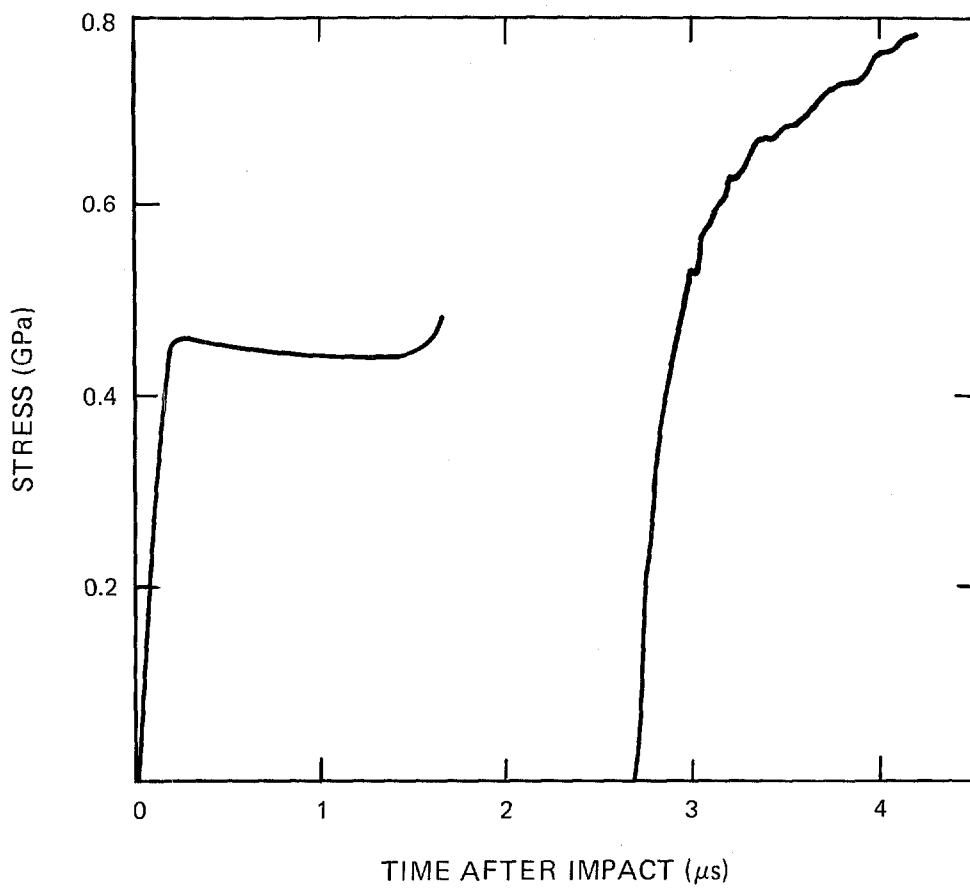

TARGET

Material: Pressed PETN

Experiment type: Quartz-gage front back

Impact stress: 1.7 GPa

Experimenters: Jerry Wackerle, P. M. Halleck, and J. O. Johnson

References: Wackerle, Johnson, and Halleck (1975a), (1976)

Shot no.: 33 **Series no.:** HDPQ

Date: January 3, 1972

Thickness: 3.05 mm **Diameter:** 40 mm

Density: 1.7 g/cm³

$C_L = 2.98$ mm/ μ s $C_s = 1.64$ mm/ μ s

Fabrication: Specimens were dry-pressed from permeametric specific surface 3000-cm²/g detonator-grade PETN and were machined into disks

IMPACTOR

Aluminum alloy projectile faced with impact-face gage described below

Impact velocity: 0.504 mm/ μ s

TRANSDUCERS

Impact face: Grounded guard-ring quartz gage

33-mm diam by 9.2 mm thick; 9.6-mm-diam electrode

Back face: Grounded guard-ring quartz gage

23-mm diam by 9.2 mm thick; 9.6-mm-diam electrode

Calibration: Wackerle, with field-fringe correction

Reference: Wackerle, Johnson, and Halleck (1975a)

Time after impact

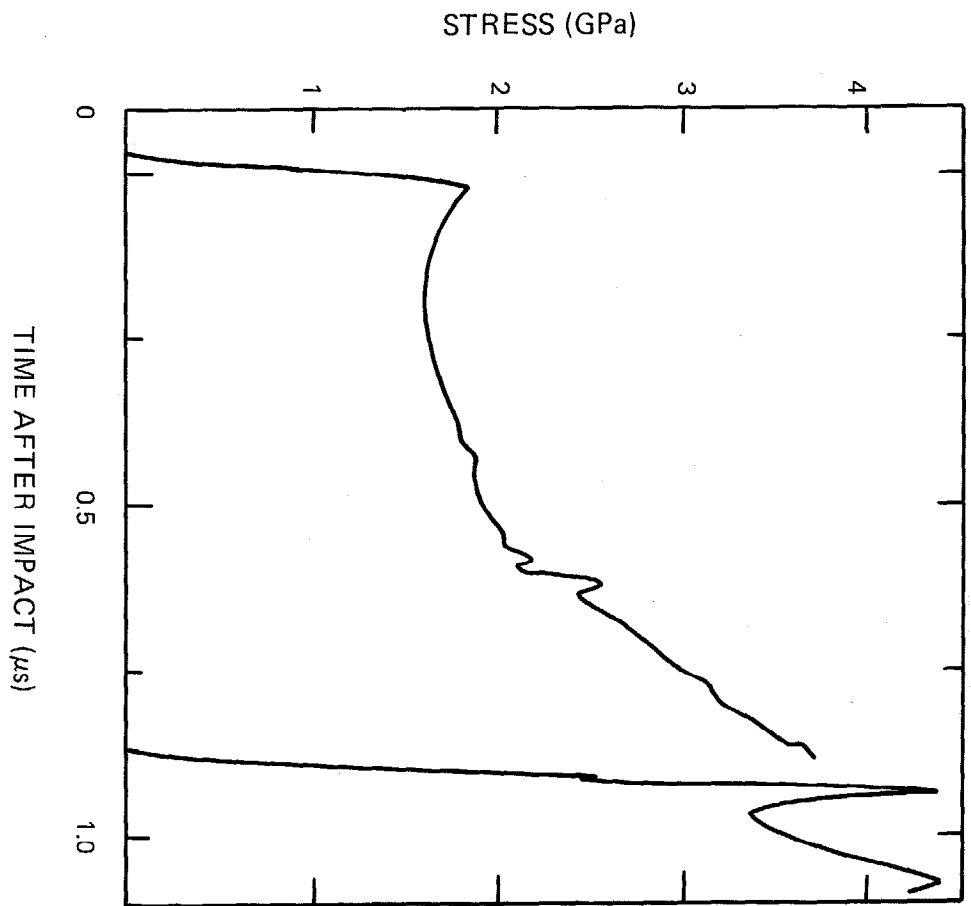

TARGET

Material: Pressed PETN
Experiment type: Quartz-gage front back
Impact stress: 0.66 GPa
Experimenters: Jerry Wackerle, P. M. Halleck, and J. O. Johnson
References: Wackerle, Johnson, and Halleck (1975a), (1976)
Shot no.: 44 **Series no.:** HDPQ
Date: February 29, 1972
Thickness: 8.12 mm **Diameter:** 40 mm
Density: 1.750 g/cm³
 $C_L = 2.98$ mm/ μ s $C_s = 1.64$ mm/ μ s
Fabrication: Specimens were dry-pressed from permeametric specific surface 3000-cm²/g detonator-grade PETN and were machined into disks

IMPACTOR

Aluminum alloy projectile faced with impact-face gage described below
Impact velocity: 0.184 mm/ μ s

TRANSDUCERS

Impact face: Grounded guard-ring quartz gage
33-mm diam by 9.2 mm thick; 9.6-mm-diam electrode
Back face: Grounded guard-ring quartz gage
23-mm diam by 9.2 mm thick; 9.6-mm-diam electrode
Calibration: Wackerle, with field-fringe correction
Reference: Wackerle, Johnson, and Halleck (1975a)
Time after impact

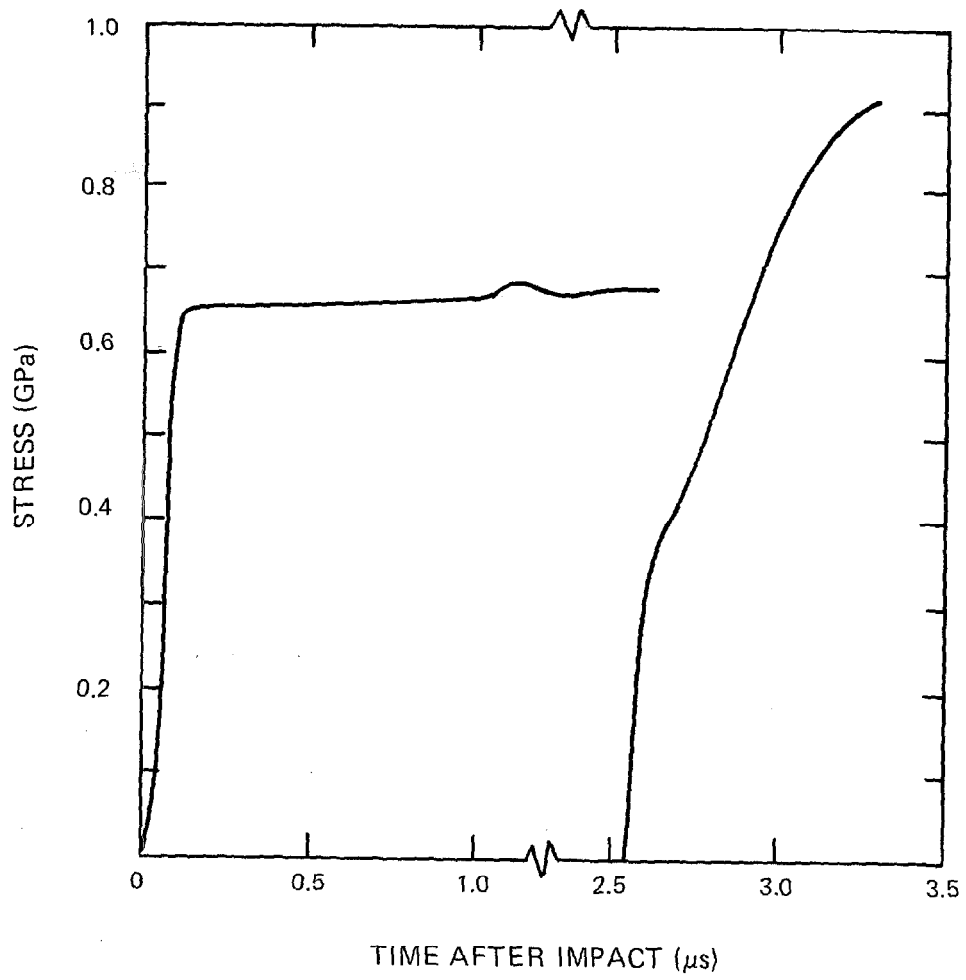

TARGET**Material:** Pressed PETN**Experiment type:** Quartz-gage front back**Impact stress:** 0.45 GPa**Experimenters:** Jerry Wackerle, P. M. Halleck, and J. O. Johnson**References:** Wackerle, Johnson, and Halleck (1975a), (1976)**Shot no.:** 45 **Series no.:** HDPQ**Date:** March 1, 1972**Thickness:** 4.04 mm **Diameter:** 40 mm**Density:** 1.750 g/cm³ $C_L = 2.98 \text{ mm}/\mu\text{s}$ $C_S = 1.64 \text{ mm}/\mu\text{s}$ **Fabrication:** Specimens were dry-pressed from permeametric specific surface 3000-cm²/g detonator-grade PETN and were machined into disks**IMPACTOR**

Aluminum alloy projectile faced with impact-face gage described below

Impact velocity: 0.121 mm/ μs **TRANSDUCERS****Impact face:** Grounded guard-ring quartz gage

33-mm diam by 9.2 mm thick; 9.6-mm-diam electrode

Back face: Grounded guard-ring quartz gage

23-mm diam by 9.2 mm thick; 9.6-mm-diam electrode

Calibration: Wackerle, with field-fringe correction**Reference:** Wackerle, Johnson, and Halleck (1975a)**Time after impact**

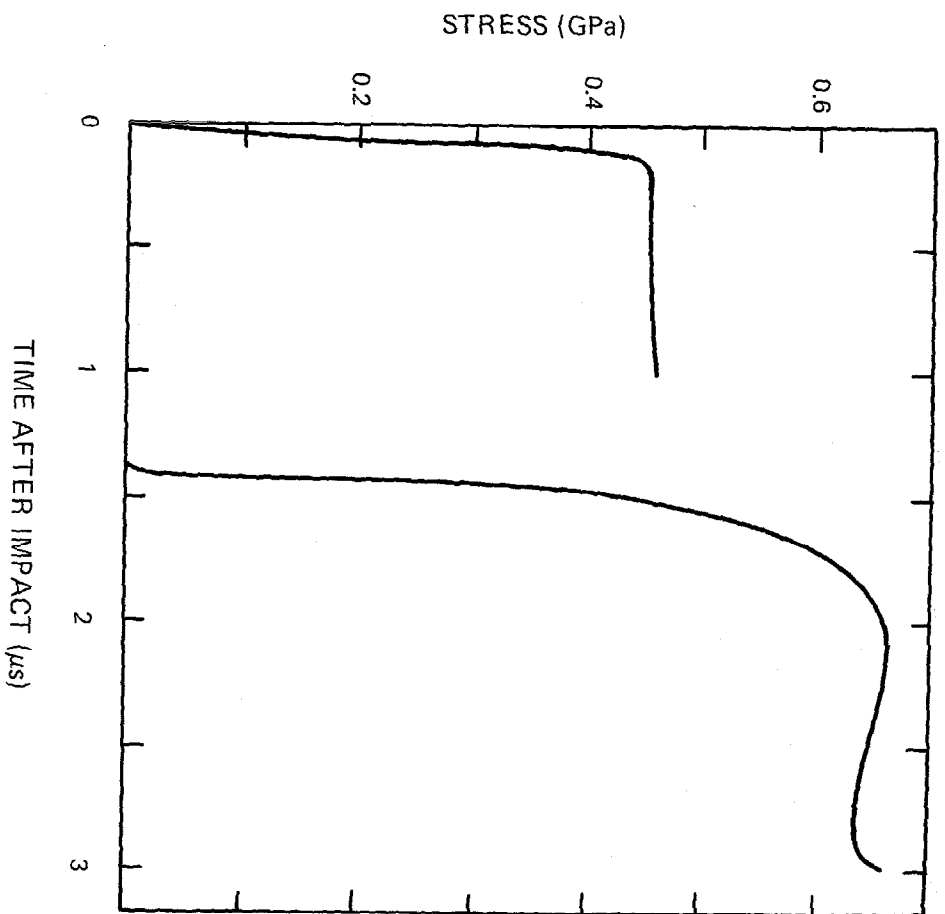

TARGET**Material:** Pressed PETN**Experiment type:** Quartz-gage front back**Impact stress:** 1.6 GPa**Experimenters:** Jerry Wackerle, P. M. Halleck, and J. O. Johnson**References:** Wackerle, Johnson, and Halleck (1975a), (1976)**Shot no.:** 97 **Series no.:** HDPQ**Date:** November 18, 1972**Thickness:** 5.10 mm **Diameter:** 40 mm**Density:** 1.7 g/cm³**C_L** = 2.98 mm/μs **C_S** = 1.64 mm/μs**Fabrication:** Specimens were dry-pressed from permeametric specific surface 3000-cm²/g detonator-grade PETN and were machined into disks**IMPACTOR**

Aluminum alloy projectile faced with impact-face gage described below

Impact velocity: 0.41 mm/μs**TRANSDUCERS****Impact face:** Grounded guard-ring quartz gage
33-mm diam by 9.2 mm thick; 9.6-mm-diam electrode**Back face:** Grounded guard-ring quartz gage
23-mm diam by 9.2 mm thick; 9.6-mm-diam electrode**Calibration:** Wackerle, with field-fringe correction**Reference:** Wackerle, Johnson, and Halleck (1975a)**Time after impact**

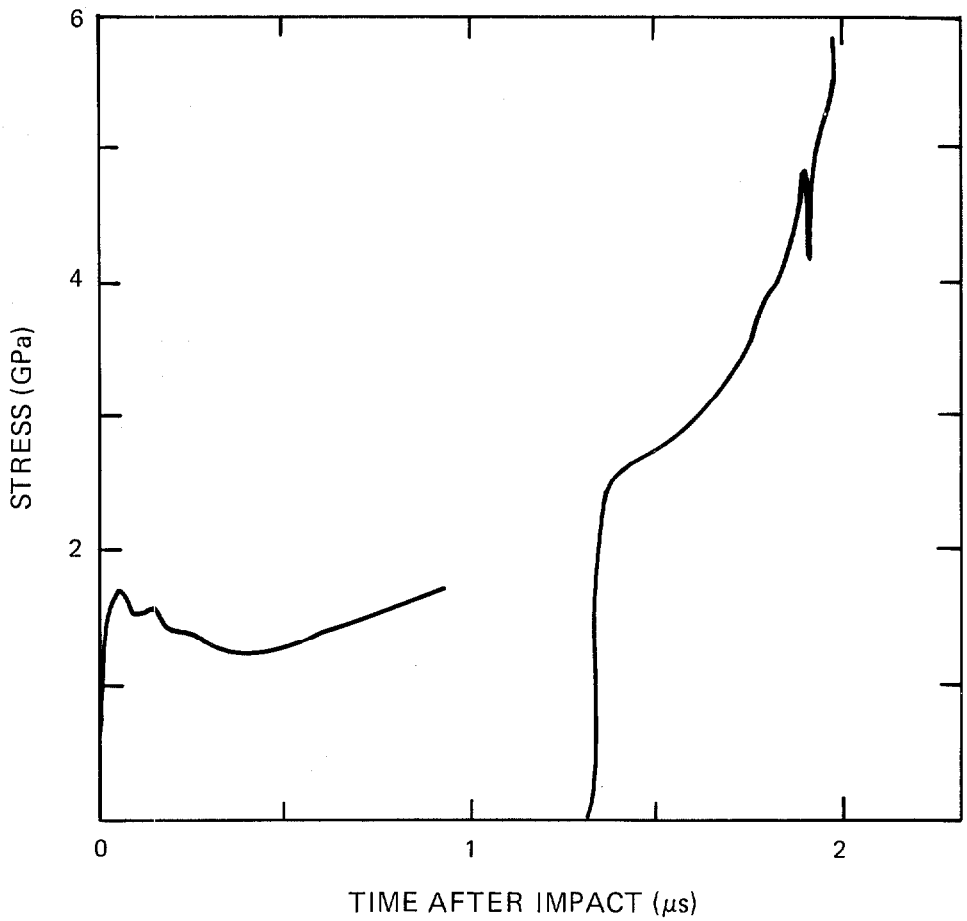

TARGET

Material: Pressed PETN
Experiment type: Quartz-gage front back
Impact stress: 0.64 GPa
Experimenters: P. M. Halleck, J. O. Johnson, and Jerry Wackerle
Reference: Wackerle, Johnson, and Halleck (1975b)
Shot no.: 195 **Series:** LDPQ **Date:** May 2, 1974
Thickness: 6.35 mm **Diameter:** 41 mm
Density: 1.402 g/cm³
Fabrication: Specimen was dry-pressed from permeametric specific surface 3000-cm²/g detonator-grade PETN and was machined into disks

IMPACTOR

Aluminum or brass projectile faced with impact-face gage described below
Impact velocity: 0.311 mm/ μ s

TRANSDUCERS

Impact face: Grounded guard-ring quartz gage
35-mm diam by 8.65 mm thick; 6.4-mm-diam electrode
Back face: Grounded guard-ring quartz gage
20-mm diam by 4.1 mm thick; 5.2-mm-diam electrode
Calibration: Wackerle, with field-fringe correction
Reference: Wackerle, Johnson, and Halleck (1975a)
Time after impact

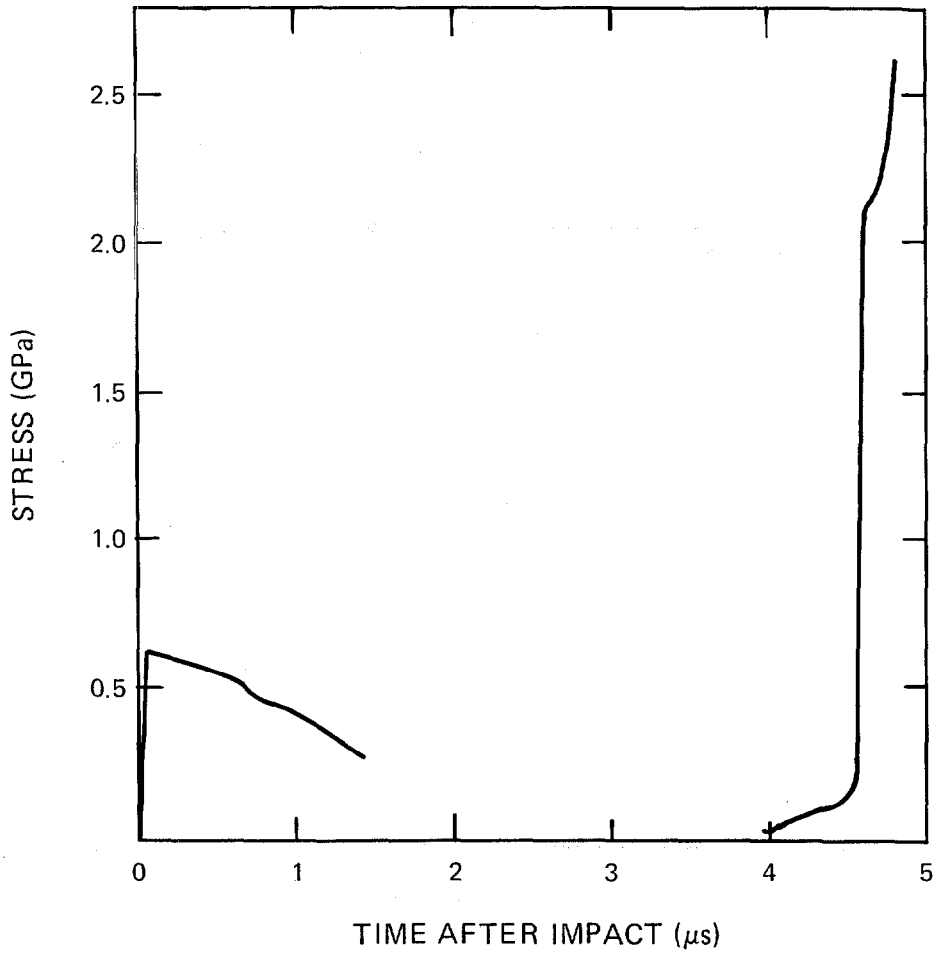

TARGET

Material: Pressed PETN

Experiment type: Quartz-gage front back

Impact stress: 0.38 GPa

Experimenters: P. M. Halleck, J. O. Johnson, and Jerry Wackerle

Reference: Wackerle, Johnson, and Halleck (1975b)

Shot no.: 196 **Series:** LDPQ **Date:** May 6, 1974

Thickness: 6.35 mm **Diameter:** 41 mm

Density: 1.403 g/cm³

Fabrication: Specimen was dry-pressed from permeametric specific surface 3000-cm²/g detonator-grade PETN and was machined into disks

IMPACTOR

Aluminum or brass projectile faced with impact-face gage described below

Impact velocity: 0.215 mm/ μ s

TRANSDUCERS

Impact face: Grounded guard-ring quartz gage

35-mm diam by 8.65 mm thick; 6.4-mm-diam electrode

Back face: Grounded guard-ring quartz gage

20-mm diam by 4.1 mm thick; 5.2-mm-diam electrode

Calibration: Wackerle, with field-fringe correction

Reference: Wackerle, Johnson, and Halleck (1975a)

Time after impact

NOTES

The target-gage record is calibrated for stress only during the first 0.7 μ s of the precursor; it serves only as an arrival-time indicator for the main shock wave.

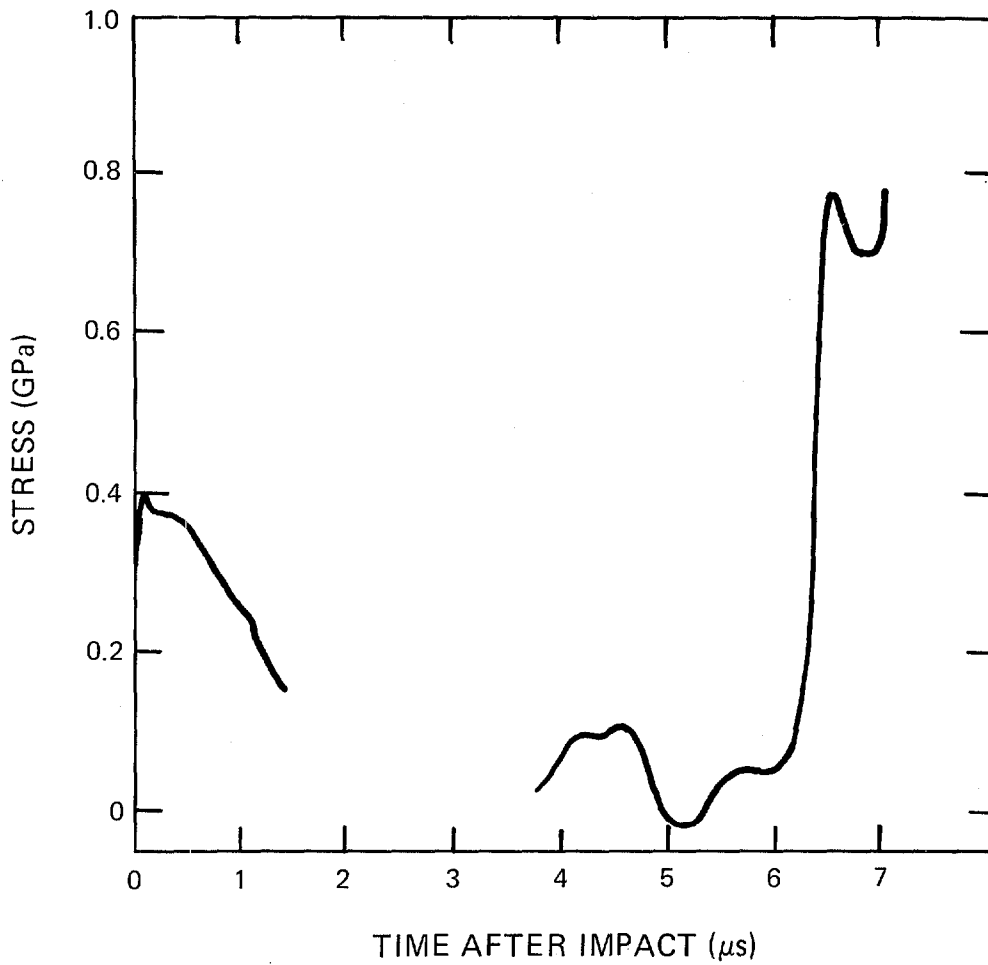

TARGET**Material:** Pressed PETN**Experiment type:** Quartz-gage front back**Impact stress:** 0.99 GPa**Experimenters:** P. M. Halleck, J. O. Johnson, and Jerry Wackerle**Reference:** Wackerle, Johnson, and Halleck (1975b)**Shot no.:** 197 **Series:** LDPQ **Date:** May 7, 1974**Thickness:** 6.34 mm **Diameter:** 41 mm**Density:** 1.400 g/cm³**Fabrication:** Specimen was dry-pressed from permeametric specific surface 3000-cm²/g detonator-grade PETN and was machined into disks**IMPACTOR**

Aluminum or brass projectile faced with impact-face gage described below

Impact velocity: 0.407 mm/ μ s**TRANSDUCERS****Impact face:** Grounded guard-ring quartz gage
35-mm diam by 8.65 mm thick; 6.4-mm-diam electrode**Back face:** Grounded guard-ring quartz gage
20-mm diam by 4.1 mm thick; 5.2-mm-diam electrode**Calibration:** Wackerle, with field-fringe correction**Reference:** Wackerle, Johnson, and Halleck (1975a)**Time after impact**

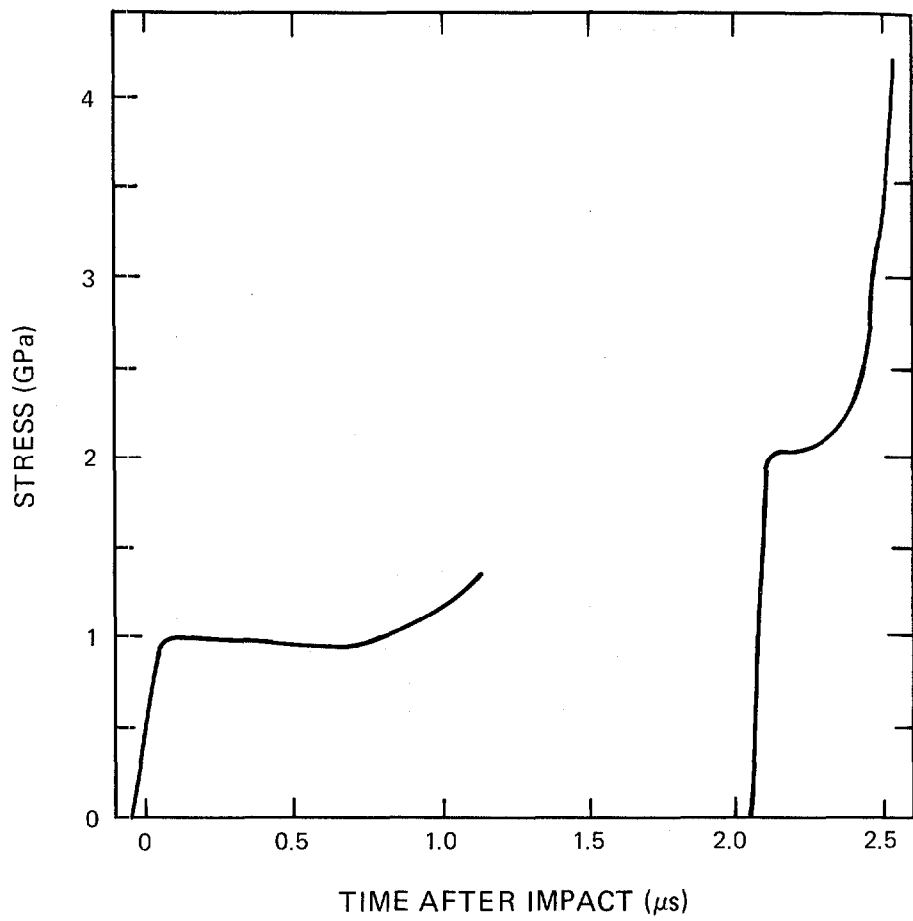

TARGET**Material:** Pressed PETN**Experiment type:** Quartz-gage front back**Impact stress:** 0.85 GPa**Experimenters:** P. M. Halleck, J. O. Johnson, and Jerry Wackerle**Reference:** Wackerle, Johnson, and Halleck (1975b)**Shot no.:** 198 **Series:** LDPQ **Date:** May 10, 1974**Thickness:** 6.35 mm **Diameter:** 41 mm**Density:** 1.399 g/cm³**Fabrication:** Specimen was dry-pressed from permeametric specific surface 3000-cm²/g detonator-grade PETN and was machined into disks**IMPACTOR**

Aluminum or brass projectile faced with impact-face gage described below

Impact velocity: 0.389 mm/ μ s**TRANSDUCERS****Impact face:** Grounded guard-ring quartz gage
35-mm diam by 8.65 mm thick; 6.4-mm-diam electrode**Back face:** Grounded guard-ring quartz gage
20-mm diam by 4.1 mm thick; 5.2-mm-diam electrode**Calibration:** Wackerle, with field-fringe correction**Reference:** Wackerle, Johnson, and Halleck (1975a)**Time after impact**

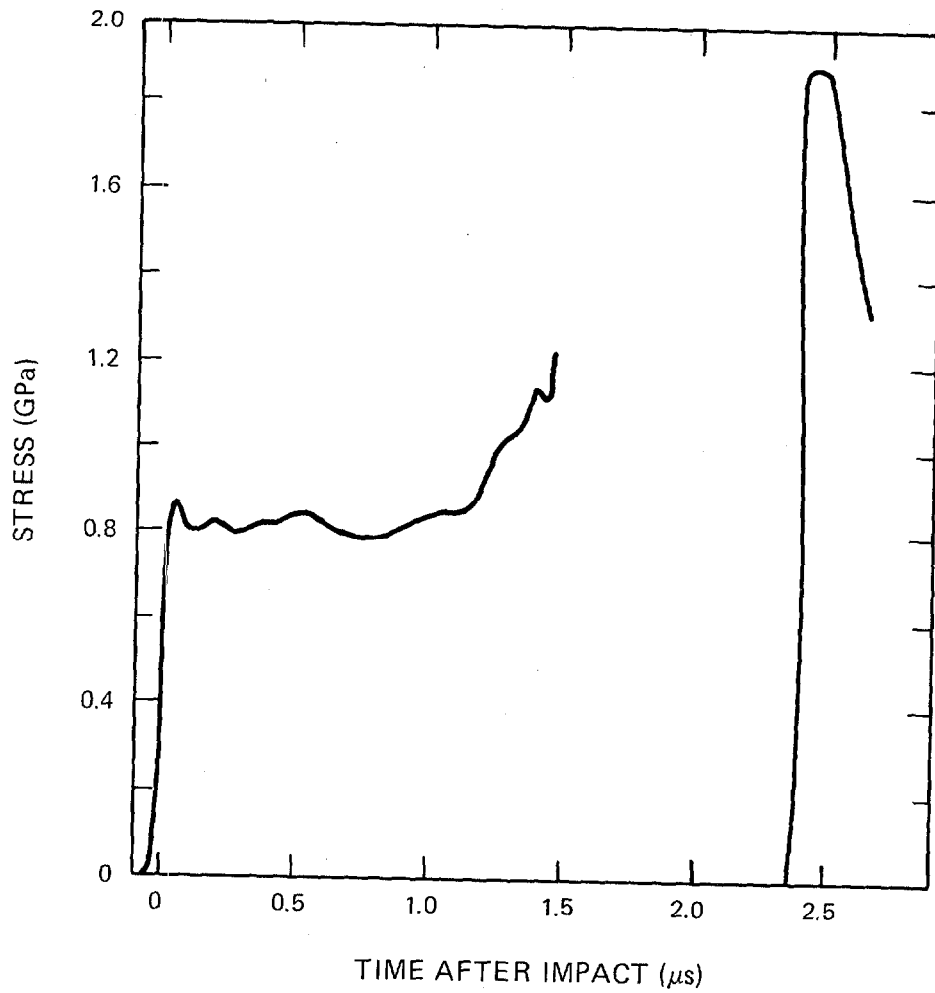

TARGET**Material:** Pressed PETN**Experiment type:** Quartz-gage front back**Impact stress:** 0.77 GPa**Experimenters:** P. M. Halleck, J. O. Johnson, and Jerry Wackerle**Reference:** Wackerle, Johnson, and Halleck (1975b)**Shot no.:** 199 **Series:** LDPQ **Date:** May 15, 1974**Thickness:** 6.35 mm **Diameter:** 41 mm**Density:** 1.404 g/cm³**Fabrication:** Specimen was dry-pressed from permeametric specific surface 3000-cm²/g detonator-grade PETN and was machined into disks**IMPACTOR**

Aluminum or brass projectile faced with impact-face gage described below

Impact velocity: 0.354 mm/μs**TRANSDUCERS****Impact face:** Grounded guard-ring quartz gage

35-mm diam by 8.65 mm thick; 6.4-mm-diam electrode

Back face: Grounded guard-ring quartz gage

20-mm diam by 4.1 mm thick; 5.2-mm-diam electrode

Calibration: Wackerle, with field-fringe correction**Reference:** Wackerle, Johnson, and Halleck (1975a)**Time after impact**

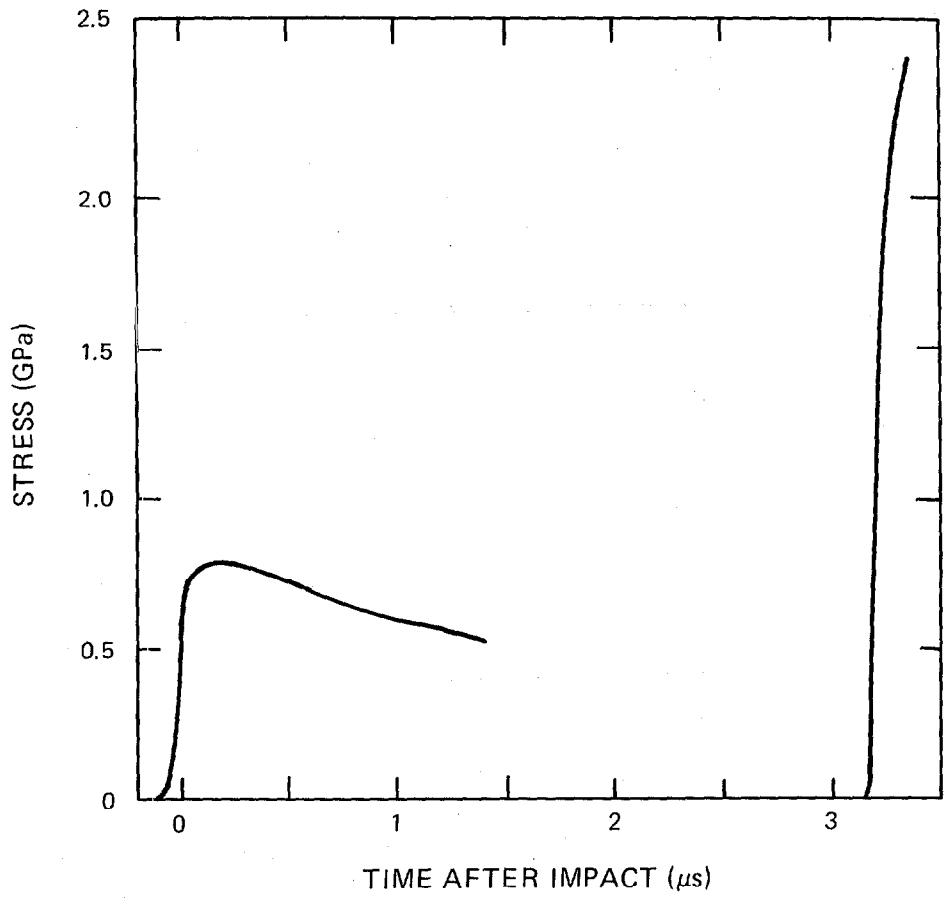

TARGET **Material:** Pressed PETN
Experiment type: Quartz-gage front back
Impact stress: 0.52 GPa
Experimenters: P. M. Halleck, J. O. Johnson, and Jerry Wackerle
Reference: Wackerle, Johnson, and Halleck (1975b)
Shot no.: 200 **Series:** LDPQ **Date:** May 16, 1974
Thickness: 6.35 mm **Diameter:** 41 mm
Density: 1.407 g/cm³
Fabrication: Specimen was dry-pressed from permeametric specific surface 3000-cm²/g detonator-grade PETN and was machined into disks

IMPACTOR Aluminum or brass projectile faced with impact-face gage described below
Impact velocity: 0.269 mm/μs

TRANSDUCERS **Impact face:** Grounded guard-ring quartz gage
35-mm diam by 8.65 mm thick; 6.4-mm-diam electrode
Back face: Grounded guard-ring quartz gage
20-mm diam by 4.1 mm thick; 5.2-mm-diam electrode
Calibration: Wackerle, with field-fringe correction
Reference: Wackerle, Johnson, and Halleck (1975a)
Time after impact

NOTES The target-gage record is calibrated for stress only during the first 0.7 μs of the precursor; it serves only as an arrival-time indicator for the main shock wave.

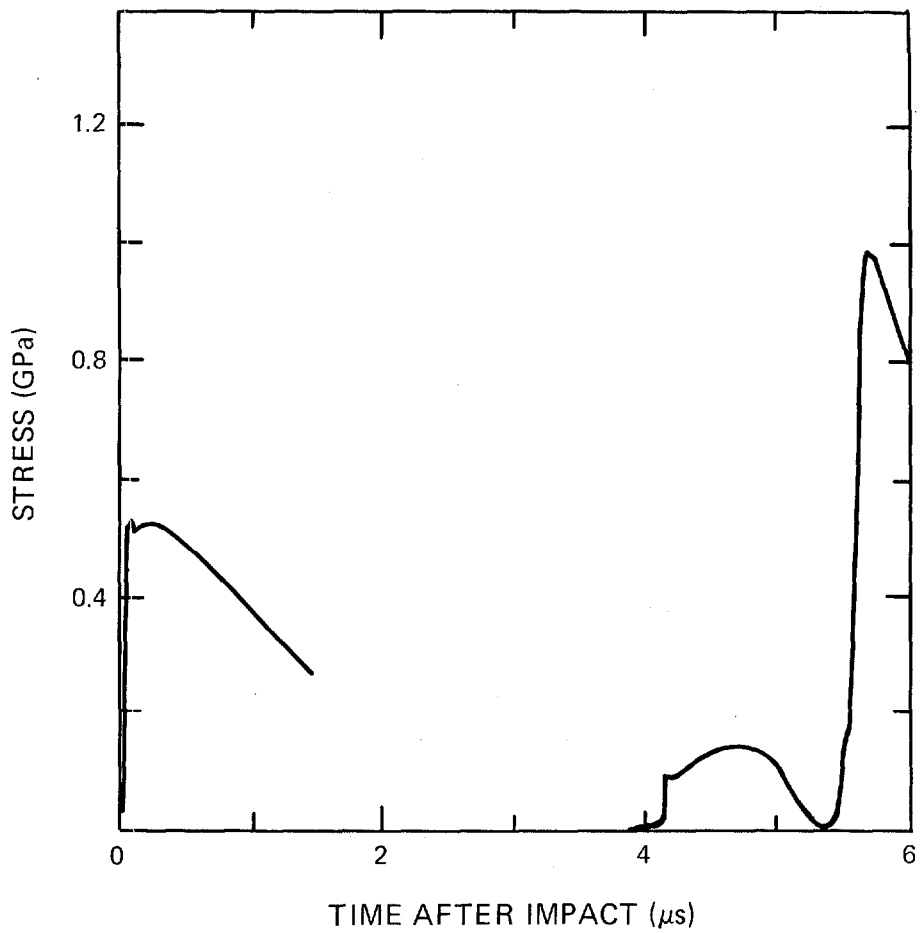

TARGET

Material: Single-crystal PETN

Experiment type: Quartz-gage front back

Impact stress: 0.84 GPa

Experimenters: P. M. Halleck and Jerry Wackerle

References: Wackerle, Johnson, and Halleck (1975a); Halleck and Wackerle (1976)

Shot no.: 91 **Series no.:** SXP **Date:** September 4, 1972

Thickness: 2.95 mm **Square side:** 30 mm

Density: 1.778 g/cm³

$C_L = 2.93$ mm/ μ s $C_S = 1.82$ mm/ μ s

Orientation: [110] (Shock propagates perpendicular to z-axis and at 45° to x- and y-axes)

Fabrication: Crystals grown in ethyl acetate solution, sawed and hand-lapped on surfaces

IMPACTOR

Aluminum alloy projectile faced with impact face x-cut quartz described below

Impact velocity: 0.227 mm/ μ s

TRANSDUCERS

Impact face: Grounded guard-ring quartz gage
31-mm diam by 9.2 mm thick; 9.7-mm-diam electrode

Back face: Grounded guard-ring quartz gage
24-mm diam by 4.8 mm thick; 6.4-mm-diam electrode

Calibration: Wackerle, with field-fringe correction

Reference: Wackerle, Johnson, and Halleck (1975a)

Time after impact

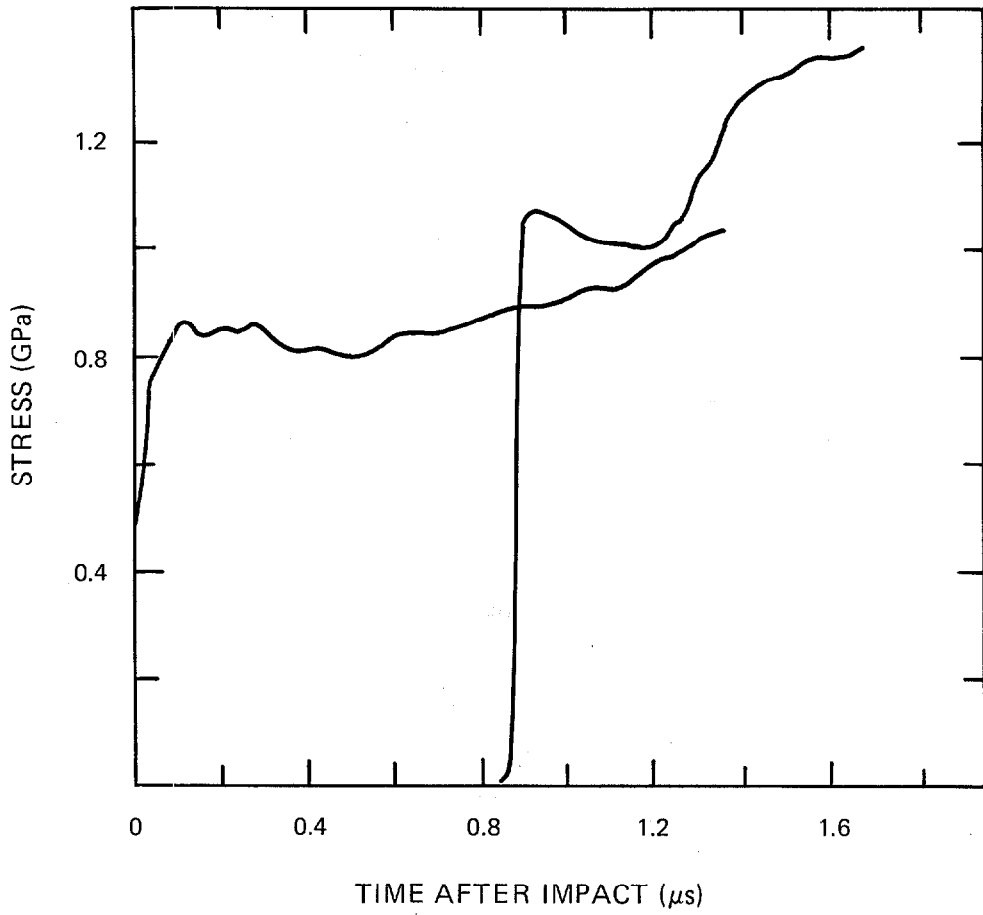

TARGET

Material: Single-crystal PETN

Experiment type: Quartz-gage front back

Impact stress: 1.2 GPa

Experimenters: P. M. Halleck and Jerry Wackerle

References: Wackerle, Johnson, and Halleck (1975a); Halleck and Wackerle (1976)

Shot no.: 102 **Series no.:** SXP **Date:** December 1, 1972

Thickness: 4.75 mm **Square side:** 24 mm

Density: 1.778 g/cm³

$C_L = 2.93$ mm/ μ s $C_S = 1.82$ mm/ μ s

Orientation: [110] (Shock propagates perpendicular to z-axis and at 45° to x- and y-axes)

Fabrication: Crystals grown in ethyl acetate solution, sawed and hand-lapped on surfaces

IMPACTOR

Aluminum alloy projectile faced with impact face x-cut quartz described below

Impact velocity: 0.30 mm/ μ s, estimated

TRANSDUCERS

Impact face: Grounded guard-ring quartz gage

20-mm diam by 4.8 mm thick; 6.4-mm-diam electrode

Back face: Grounded guard-ring quartz gage

16-mm diam by 4.8 mm thick; 6.5-mm-diam electrode

Calibration: Wackerle, with field-fringe correction

Reference: Wackerle, Johnson, and Halleck (1975a)

Time after impact

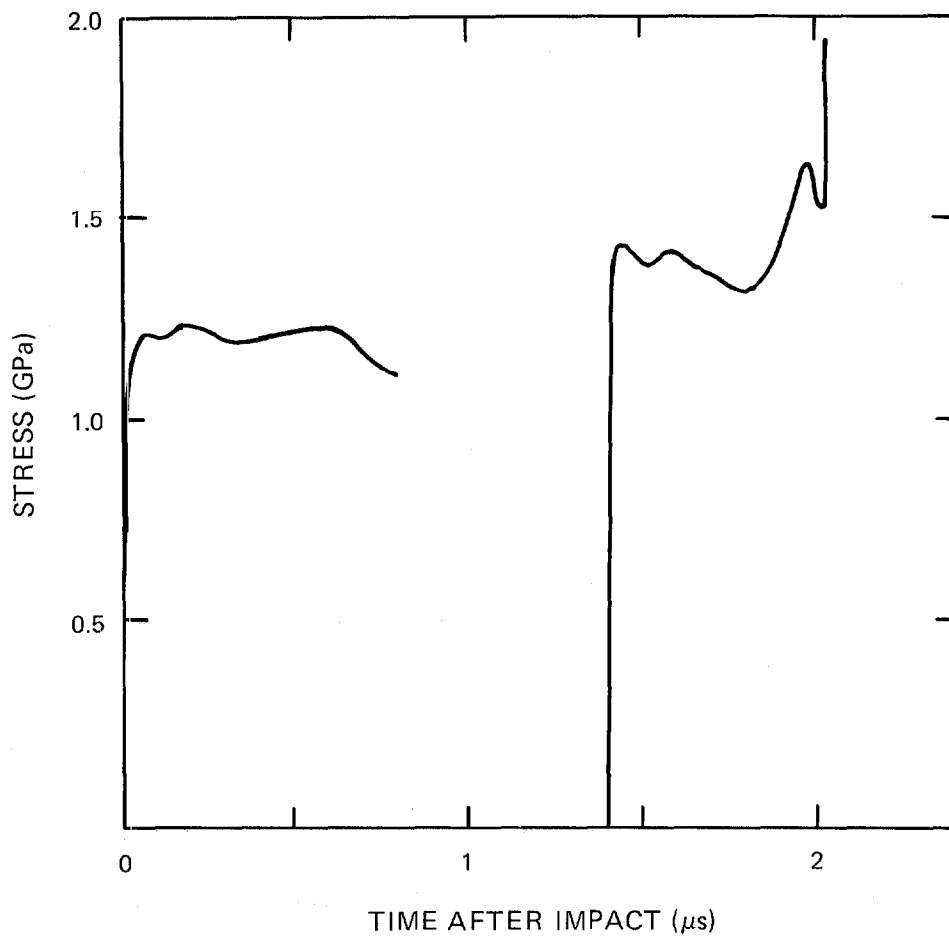

TARGET **Material:** Single-crystal PETN
Experiment type: Quartz-gage front back
Impact stress: 0.67 GPa
Experimenters: P. M. Halleck and Jerry Wackerle
References: Wackerle, Johnson, and Halleck (1975a), (1976)
Shot no.: 118 **Series no.:** SXP **Date:** May 22, 1973
Thickness: 5.06 mm **Square side:** 25 mm
Density: 1.778 g/cm³
 $C_L = 2.93$ mm/ μ s $C_S = 1.82$ mm/ μ s
Orientation: [110] (Shock propagates perpendicular to z-axis and at 45° to x- and y-axes)
Fabrication: Crystals grown in ethyl acetate solution, sawed and hand-lapped on surfaces

IMPACTOR Aluminum alloy projectile faced with impact face x-cut quartz described below
Impact velocity: 0.174 mm/ μ s

TRANSDUCERS **Impact face:** Grounded guard-ring quartz gage
24-mm diam by 4.6 mm thick; 6.5-mm-diam electrode
Back face: Grounded guard-ring quartz gage
19-mm diam by 4.6 mm thick; 6.5-mm-diam electrode
Calibration: Wackerle, with field-fringe correction
Reference: Wackerle, Johnson, and Halleck (1975a)
Time after impact

NOTES Impact face record lost; only back face record shown

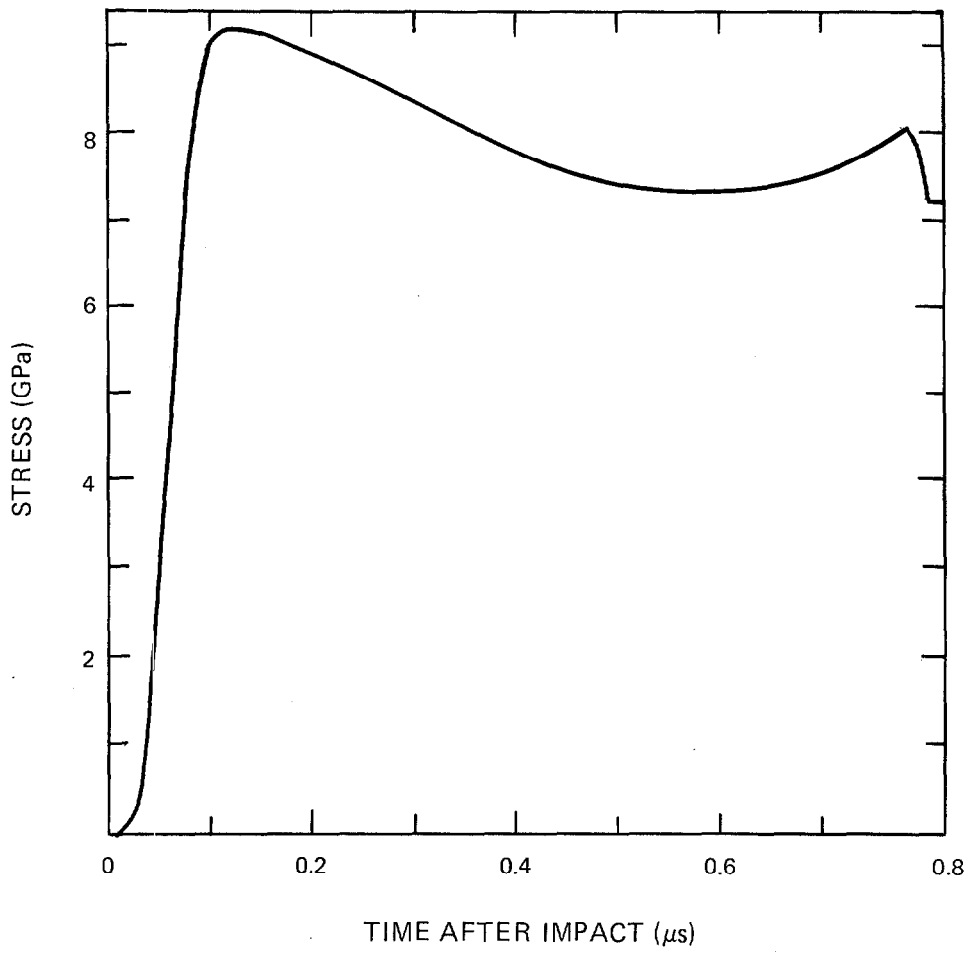

TARGET

Material: Single-crystal PETN

Experiment type: Quartz-gage front back

Impact stress: 2.5 GPa

Experimenters: P. M. Halleck and Jerry Wackerle

References: Wackerle, Johnson, and Halleck (1975a), Halleck and Wackerle (1976)

Shot no.: 119 **Series no.:** SXP **Date:** May 23, 1973

Thickness: 5.08 mm **Square side:** 28 mm

Density: 1.778 g/cm³

$C_L = 2.93$ mm/ μ s $C_S = 1.82$ mm/ μ s

Orientation: [110] (Shock propagates perpendicular to z-axis and at 45° to x- and y-axes)

Fabrication: Crystals grown in ethyl acetate solution, sawed and hand-lapped on surfaces

IMPACTOR

Aluminum alloy projectile faced with impact face x-cut quartz described below

Impact velocity: 0.598 mm/ μ s

TRANSDUCERS

Impact face: Grounded guard-ring quartz gage

24-mm diam by 4.6 mm thick; 6.5-mm-diam electrode

Back face: Grounded guard-ring quartz gage

19-mm diam by 4.6 mm thick; 6.5-mm-diam electrode

Calibration: Wackerle, with field-fringe correction

Reference: Wackerle, Johnson, and Halleck (1975a)

Time after impact

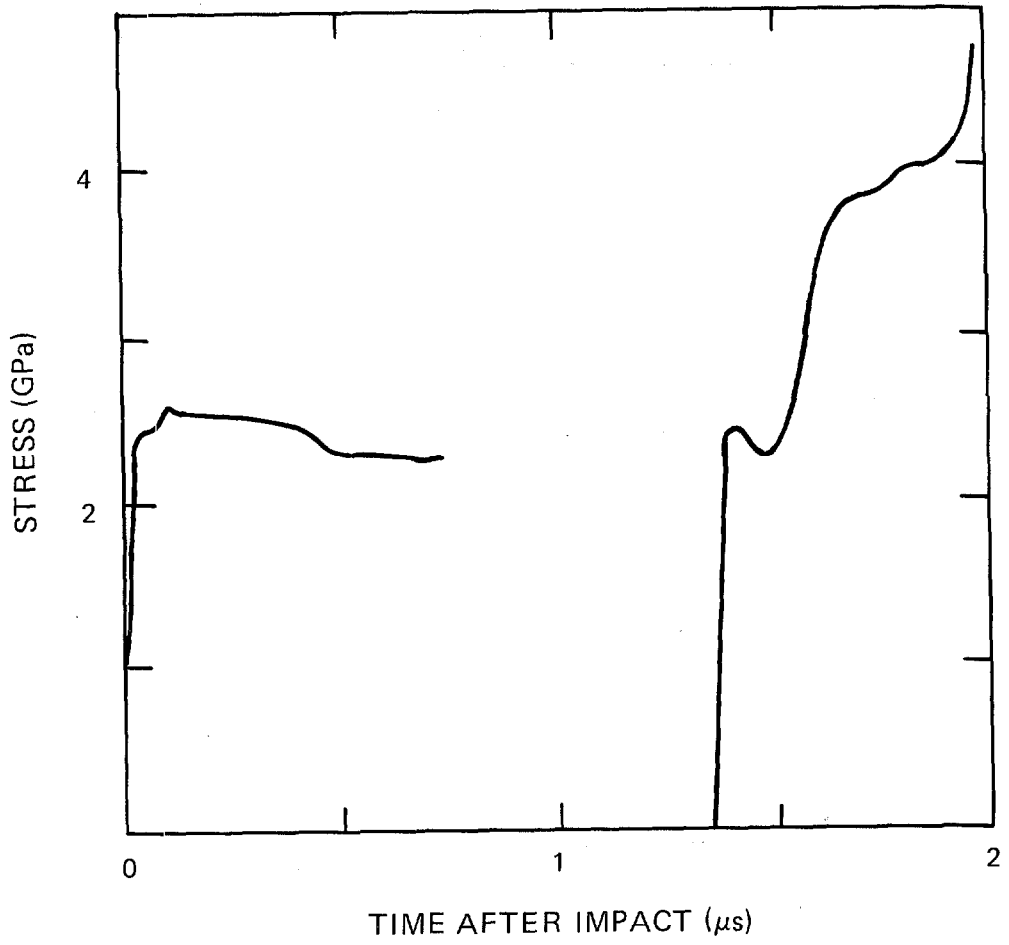

TARGET

Material: Single-crystal PETN
Experiment type: Quartz-gage front back
Impact stress: 0.9 GPa
Experimenters: P. M. Halleck and Jerry Wackerle
References: Wackerle, Johnson, and Halleck (1975a), Halleck and Wackerle (1976)
Shot no.: 120 **Series no.:** SXP **Date:** May 24, 1973
Thickness: 5.07 mm **Square side:** 25 mm
Density: 1.778 g/cm³
 $C_L = 2.62$ mm/ μ s $C_s = 1.68$ mm/ μ s
Orientation: [001] (Shock propagates along z-axis)
Fabrication: Crystals grown in ethyl acetate solution, sawed and hand-lapped on surfaces

IMPACTOR

Aluminum alloy projectile faced with impact face x-cut quartz
Impact velocity: 0.236 mm/ μ s
Calibration: Wackerle, with field-fringe correction
Reference: Wackerle, Johnson, and Halleck (1975a)
Time after impact

TRANSDUCERS

Impact face: Grounded guard-ring quartz gage
24-mm diam by 4.6 mm thick; 6.5-mm-diam electrode
Back face: Grounded guard-ring quartz gage
24-mm diam by 4.6 mm thick; 6.5-mm-diam electrode
Calibration: Wackerle, with field-fringe correction
Reference: Wackerle, Johnson, and Halleck (1975a)

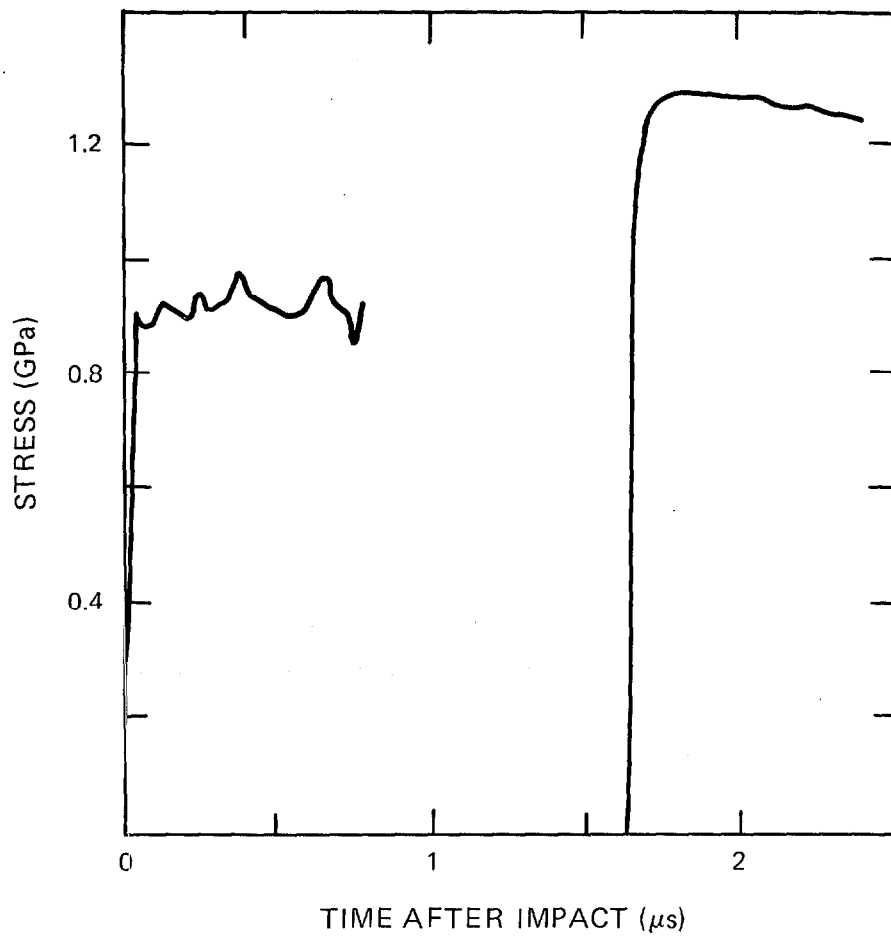

TARGET

Material: Single-crystal PETN
Experiment type: Quartz-gage front back
Impact stress: 2.0 GPa
Experimenters: P. M. Halleck and Jerry Wackerle
References: Wackerle, Johnson, and Halleck (1975a), Halleck and Wackerle (1976)
Shot no.: 124 **Series no.:** SXP **Date:** June 13, 1973
Thickness: 5.07 mm **Square side:** 25 mm
Density: 1.778 g/cm³
C_L = 2.62 mm/μs **C_s =** 1.68 mm/μs
Orientation: [001] (Shock propagates along z-axis)
Fabrication: Crystals grown in ethyl acetate solution, sawed and hand-lapped on surfaces

IMPACTOR

Aluminum alloy projectile faced with impact face x-cut quartz described below
Impact velocity: 0.453 mm/μs

TRANSDUCERS

Impact face: Grounded guard-ring quartz gage
20-mm diam by 6.1 mm thick; 6.5-mm-diam electrode
Back face: Grounded guard-ring quartz gage
18-mm diam by 4.6 mm thick; 6.5-mm-diam electrode
Calibration: Wackerle, with field-fringe correction
Reference: Wackerle, Johnson, and Halleck (1975a)
Time after impact

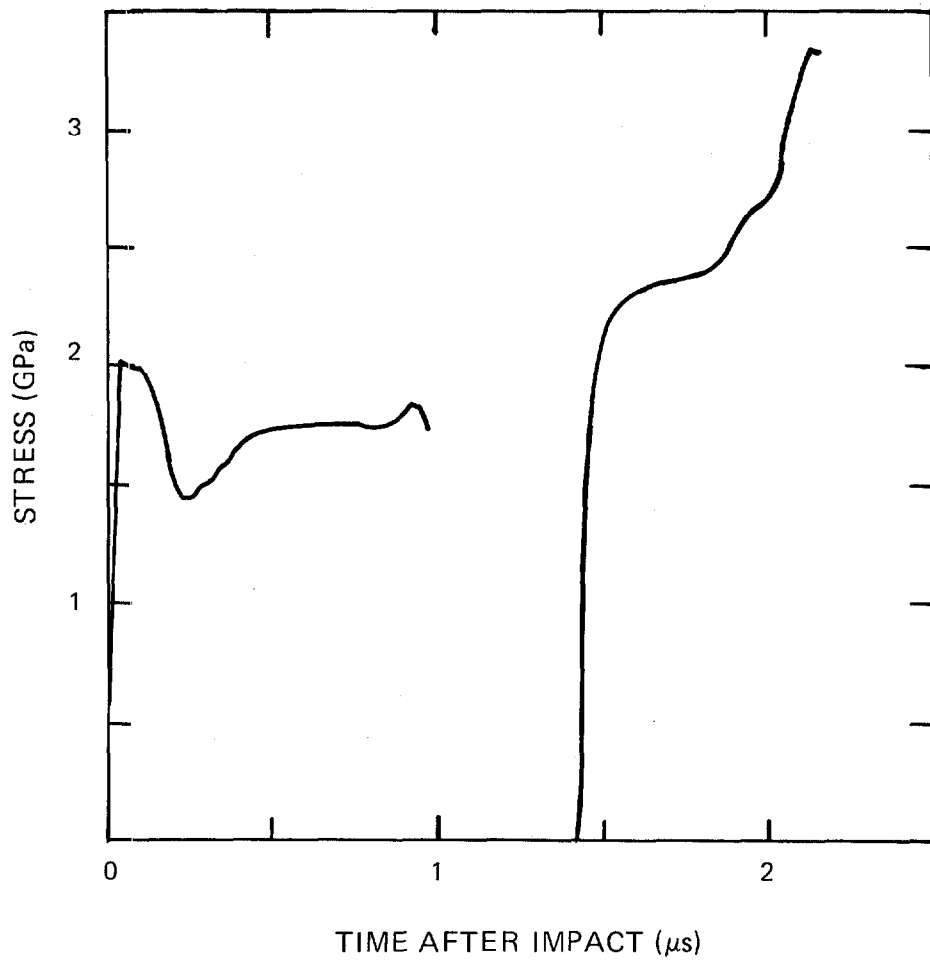

TARGET

Material: Single-crystal PETN

Experiment type: Quartz-gage front back

Impact stress: 2.5 GPa

Experimenters: P. M. Halleck and Jerry Wackerle

References: Wackerle, Johnson, and Halleck (1975a), Halleck and Wackerle (1976)

Shot no.: 125 **Series no.:** SXP **Date:** June 18, 1973

Thickness: 5.07 mm **Square side:** 25 mm

Density: 1.778 g/cm³

$C_L = 2.62$ mm/ μ s $C_S = 1.68$ mm/ μ s

Orientation: [001] (Shock propagates along z-axis)

Fabrication: Crystals grown in ethyl acetate solution, sawed and hand-lapped on surfaces

IMPACTOR

Aluminum alloy projectile faced with impact face x-cut quartz described below

Impact velocity: 0.591 mm/ μ s

TRANSDUCERS

Impact face: Grounded guard-ring quartz gage

20-mm diam by 4.6 mm thick; 6.5-mm-diam electrode

Back face: Grounded guard-ring quartz gage

18-mm diam by 4.6 mm thick; 6.5-mm-diam electrode

Calibration: Wackerle, with field-fringe correction

Reference: Wackerle, Johnson, and Halleck (1975a)

Time after impact

NOTES

Impact face record lost; only back face record shown

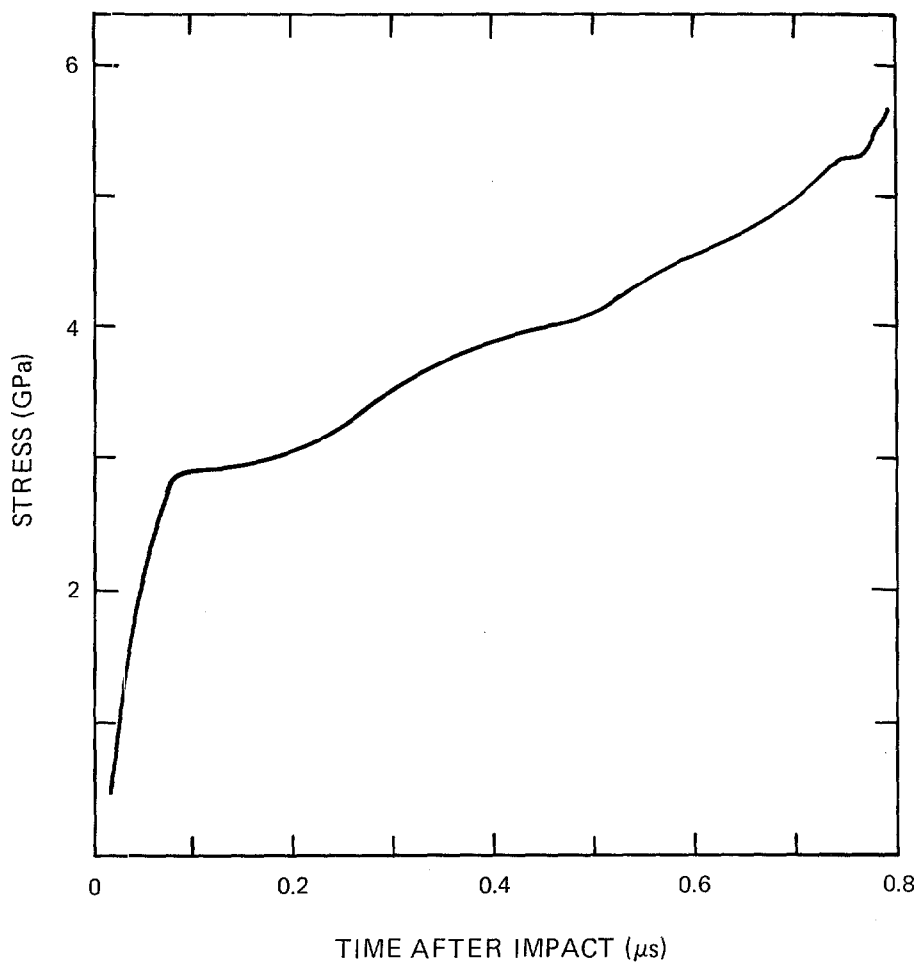

TARGET

Material: Single-crystal PETN

Experiment type: Quartz-gage front back

Impact stress: 1.95 GPa

Experimenters: P. M. Halleck and Jerry Wackerle

References: Wackerle, Johnson, and Halleck (1975a), Halleck and Wackerle (1976)

Shot no.: 152 **Series no.:** SXP **Date:** October 12, 1973

Thickness: 3.81 mm **Square side:** 24 mm

Density: 1.778 g/cm³

$C_L = 2.93$ mm/ μ s $C_s = 1.82$ mm/ μ s

Orientation: [110] (Shock propagates perpendicular to z-axis and at 45° to x- and y-axes)

Fabrication: Crystals grown in ethyl acetate solution, sawed and hand-lapped on surfaces

IMPACTOR

Aluminum alloy projectile faced with impact face x-cut quartz described below

Impact velocity: 0.452 mm/ μ s

TRANSDUCERS

Impact face: Grounded guard-ring quartz gage

20-mm diam by 4.08 mm thick; 5.2-mm-diam electrode

Back face: Grounded guard-ring quartz gage

16-mm diam by 4.08 mm thick; 5.2-mm-diam electrode

Calibration: Wackerle, with field-fringe correction

Reference: Wackerle, Johnson, and Halleck (1975a)

Time after impact

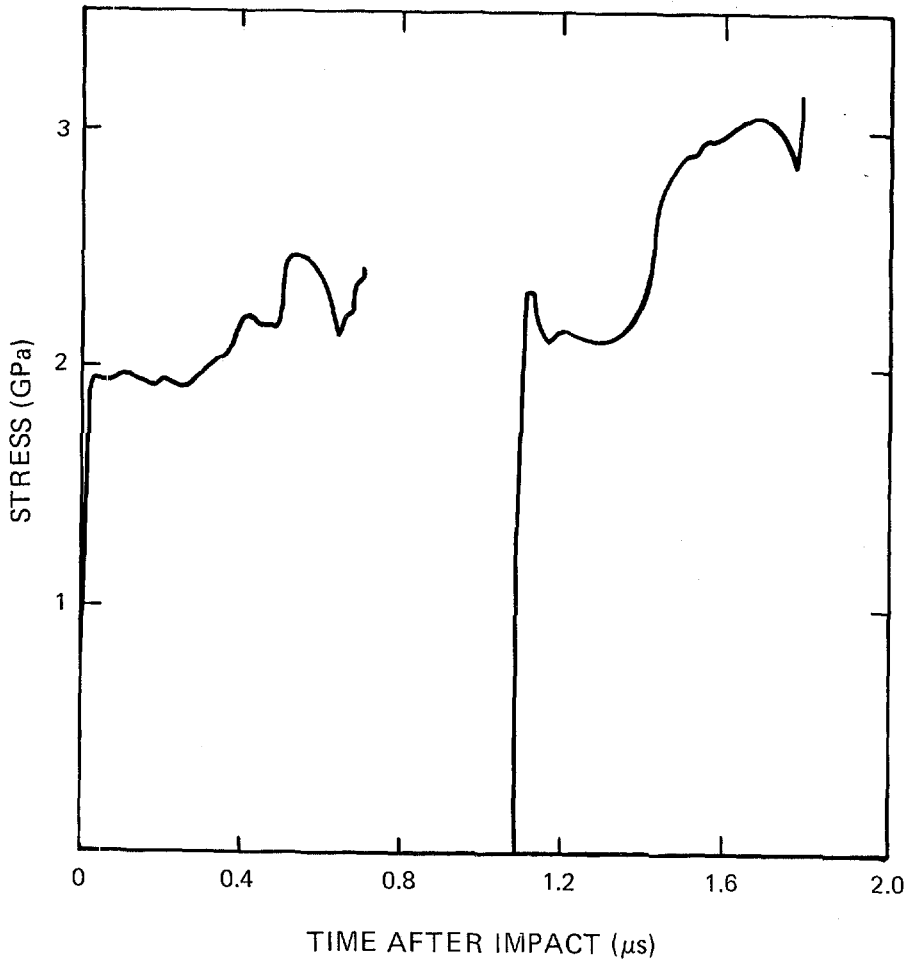

TARGET**Material:** Single-crystal PETN**Experiment type:** Quartz-gage front back**Impact stress:** 2.64 GPa**Experimenters:** P. M. Halleck and Jerry Wackerle**References:** Wackerle, Johnson, and Halleck (1975a), Halleck and Wackerle (1976)**Shot no.:** 154 **Series no.:** SXP **Date:** October 17, 1973**Thickness:** 3.82 mm **Square side:** 25 mm**Density:** 1.778 g/cm³**C_L** = 2.93 mm/μs **C_s** = 1.82 mm/μs**Orientation:** [110] (Shock propagates perpendicular to z-axis and at 45° to x- and y-axes)**Fabrication:** Crystals grown in ethyl acetate solution, sawed and hand-lapped on surfaces**IMPACTOR**

Aluminum alloy projectile faced with impact face x-cut quartz described below

Impact velocity: 0.608 mm/μs**TRANSDUCERS****Impact face:** Grounded guard-ring quartz gage

20-mm diam by 4.08 mm thick; 5.2-mm-diam electrode

Back face: Grounded guard-ring quartz gage

16-mm diam by 4.08 mm thick; 5.2-mm-diam electrode

Calibration: Wackerle, with field-fringe correction**Reference:** Wackerle, Johnson, and Halleck (1975a)**Time after impact**

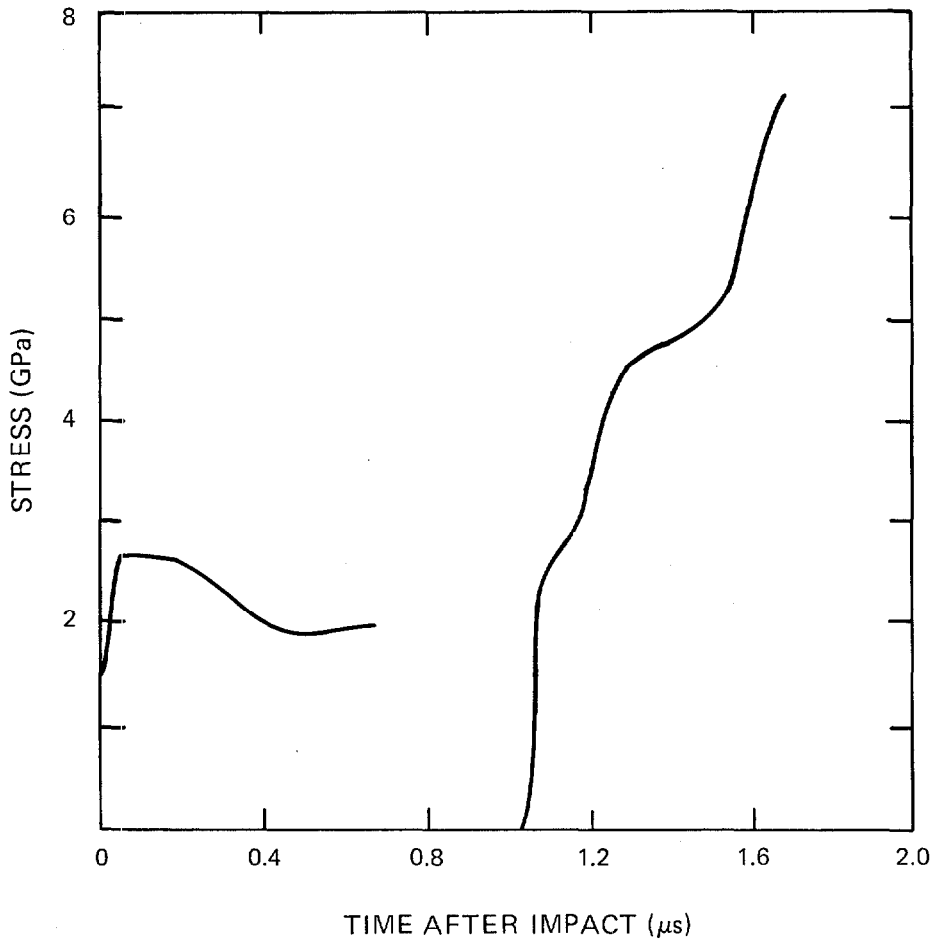

TARGET

Material: Single-crystal PETN

Experiment type: Quartz-gage front back

Impact stress: 2.74 GPa

Experimenters: P. M. Halleck and Jerry Wackerle

References: Wackerle, Johnson, and Halleck (1975a), Halleck and Wackerle (1976)

Shot no.: 156 **Series no.:** SXP **Date:** October 23, 1973

Thickness: 5.06 mm **Square side:** 25 mm

Density: 1.778 g/cm³

$C_L = 2.93$ mm/ μ s $C_S = 1.82$ mm/ μ s

Orientation: [110] (Shock propagates perpendicular to z-axis and at 45° to x- and y-axes)

Fabrication: Crystals grown in ethyl acetate solution, sawed and hand-lapped on surfaces

IMPACTOR

Aluminum alloy projectile faced with impact face x-cut quartz described below

Impact velocity: 0.600 mm/ μ s

TRANSDUCERS

Impact face: Grounded guard-ring quartz gage

20-mm diam by 4.08 mm thick; 5.2-mm-diam electrode

Back face: Grounded guard-ring quartz gage

15-mm diam by 4.08 mm thick; 5.2-mm-diam electrode

Calibration: Wackerle, with field-fringe correction

Reference: Wackerle, Johnson, and Halleck (1975a)

Time after impact

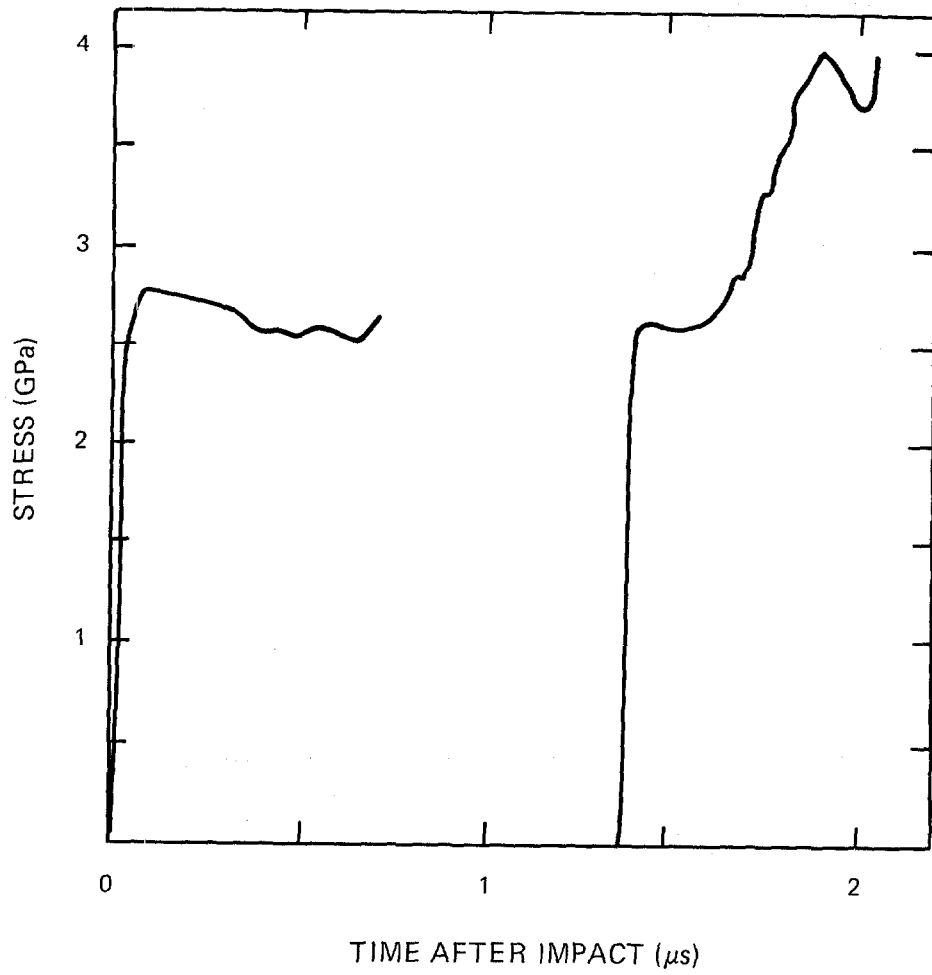

TARGET

Material: Single-crystal PETN

Experiment type: Quartz-gage front back

Impact stress: 4.0 GPa

Experimenters: P. M. Halleck and Jerry Wackerle

References: Wackerle, Johnson, and Halleck (1975a), Halleck and Wackerle (1976)

Shot no.: 158 **Series no.:** SXP **Date:** October 30, 1973

Thickness: 3.83 mm **Square side:** 25 mm

Density: 1.778 g/cm³

$C_L = 2.93$ mm/ μ s $C_S = 1.82$ mm/ μ s

Orientation: [110] (Shock propagates perpendicular to z-axis and at 45° to x- and y-axes)

Fabrication: Crystals grown in ethyl acetate solution, sawed and hand-lapped on surfaces

IMPACTOR

Aluminum alloy projectile faced with impact face x-cut quartz described below

Impact velocity: 0.860 mm/ μ s

TRANSDUCERS

Impact face: Grounded guard-ring quartz gage

20-mm diam by 4.08 mm thick; 5.2-mm-diam electrode

Back face: Grounded guard-ring quartz gage

15-mm diam by 4.08 mm thick; 5.2-mm-diam electrode

Calibration: Wackerle, with field-fringe correction

Reference: Wackerle, Johnson, and Halleck (1975a)

Time after impact

NOTE

Back-face stress exceeds gage limit

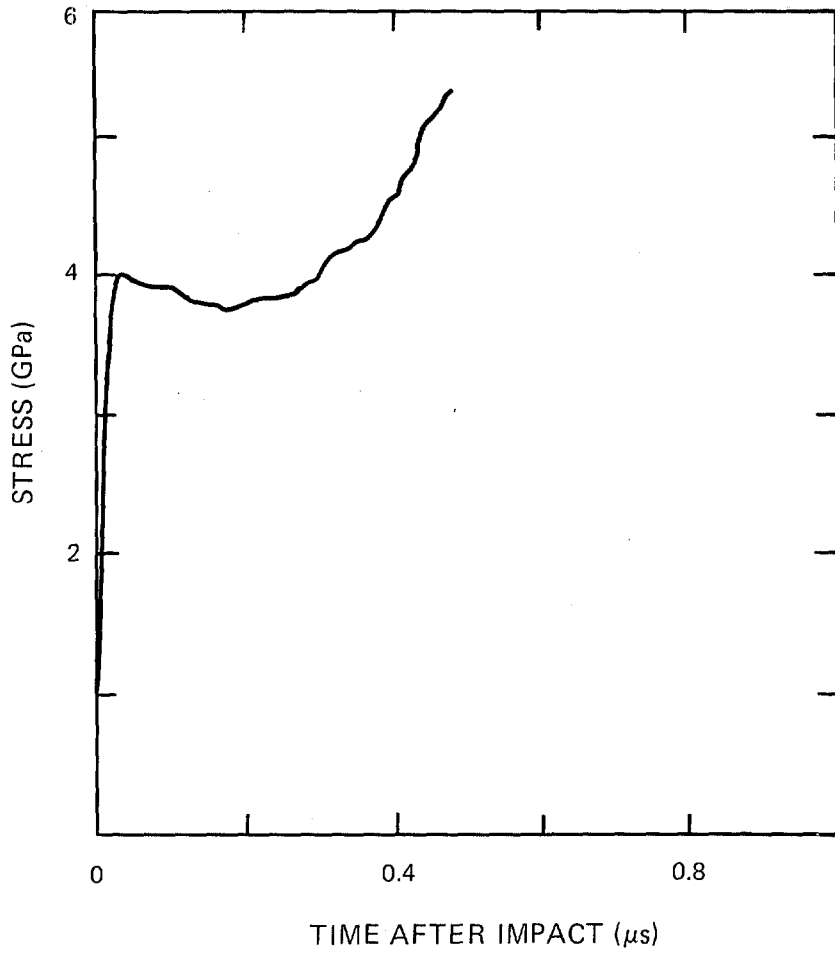

TARGET

Material: Single-crystal PETN

Experiment type: Quartz-gage front back

Impact stress: 2.64 GPa

Experimenters: P. M. Halleck and Jerry Wackerle

References: Wackerle, Johnson, and Halleck (1975a), Halleck and Wackerle (1976)

Shot no.: 159 **Series no.:** SXP **Date:** November 1, 1973

Thickness: 2.77 mm **Square side:** 25 mm

Density: 1.778 g/cm³

$C_L = 2.93$ mm/ μ s $C_S = 1.82$ mm/ μ s

Orientation: [110] (Shock propagates perpendicular to z-axis and at 45° to x- and y-axes)

Fabrication: Crystals grown in ethyl acetate solution, sawed and hand-lapped on surfaces

IMPACTOR

Aluminum alloy projectile faced with impact face x-cut quartz described below

Impact velocity: 0.599 mm/ μ s

TRANSDUCERS

Impact face: Grounded guard-ring quartz gage
20-mm diam by 4.08 mm thick; 5.2-mm-diam electrode

Back face: Grounded guard-ring quartz gage
15-mm diam by 4.08 mm thick; 5.2-mm-diam electrode

Calibration: Wackerle, with field-fringe correction

Reference: Wackerle, Johnson, and Halleck (1975a)

Time after impact

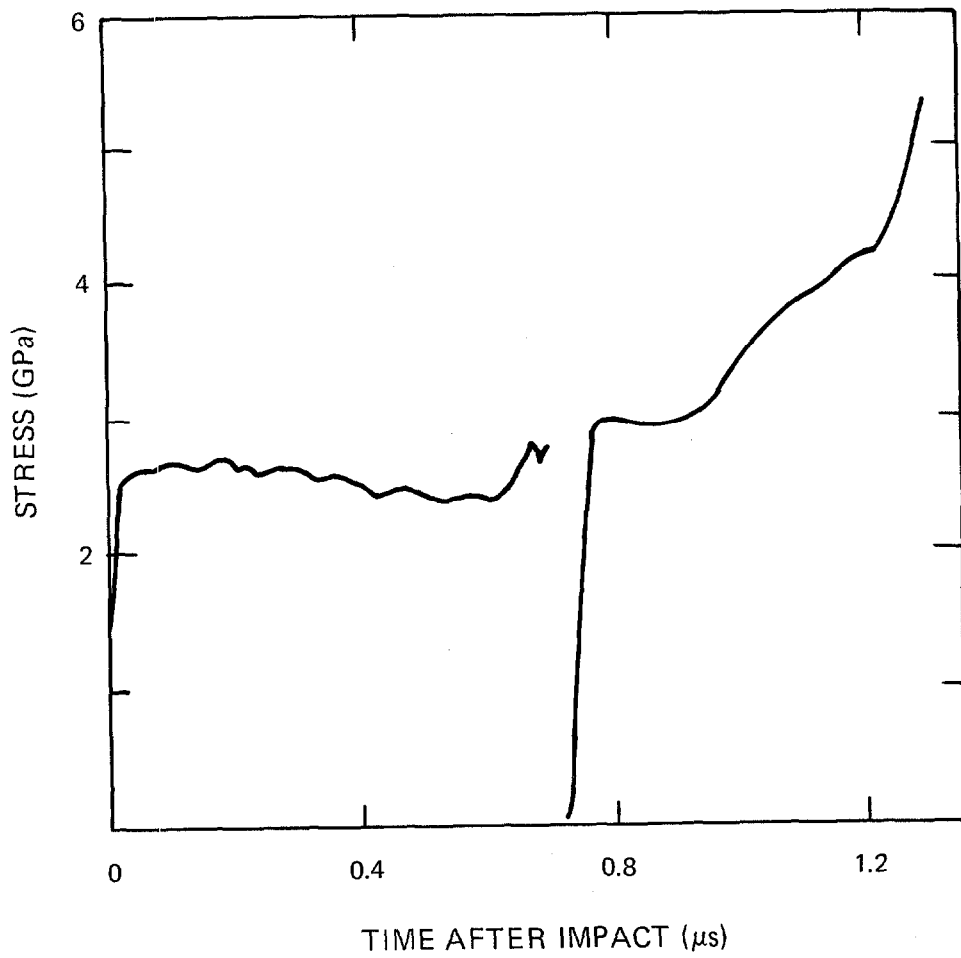

TARGET

Material: Single-crystal PETN

Experiment type: Quartz-gage front back

Impact stress: 4.1 GPa

Experimenters: P. M. Halleck and Jerry Wackerle

References: Wackerle, Johnson, and Halleck (1975a), Halleck and Wackerle (1976)

Shot no.: 160 **Series no.:** SXP **Date:** November 3, 1973

Thickness: 4.16 mm **Square side:** 25 mm

Density: 1.778 g/cm³

$C_L = 2.93$ mm/ μ s $C_S = 1.82$ mm/ μ s

Orientation: [110] (Shock propagates perpendicular to z-axis and at 45° to x- and y-axes)

Fabrication: Crystals grown in ethyl acetate solution, sawed and hand-lapped on surfaces

IMPACTOR

Aluminum alloy projectile faced with impact face x-cut quartz described below

Impact velocity: 0.865 mm/ μ s

TRANSDUCERS

Impact face: Grounded guard-ring quartz gage

20-mm diam by 4.08 mm thick; 5.2-mm-diam electrode

Back face: Grounded guard-ring quartz gage

15-mm diam by 4.08 mm thick; 5.2-mm-diam electrode

Calibration: Wackerle, with field-fringe correction

Reference: Wackerle, Johnson, and Halleck (1975a)

Time after impact

NOTES

Back-face stress exceeds gage limit

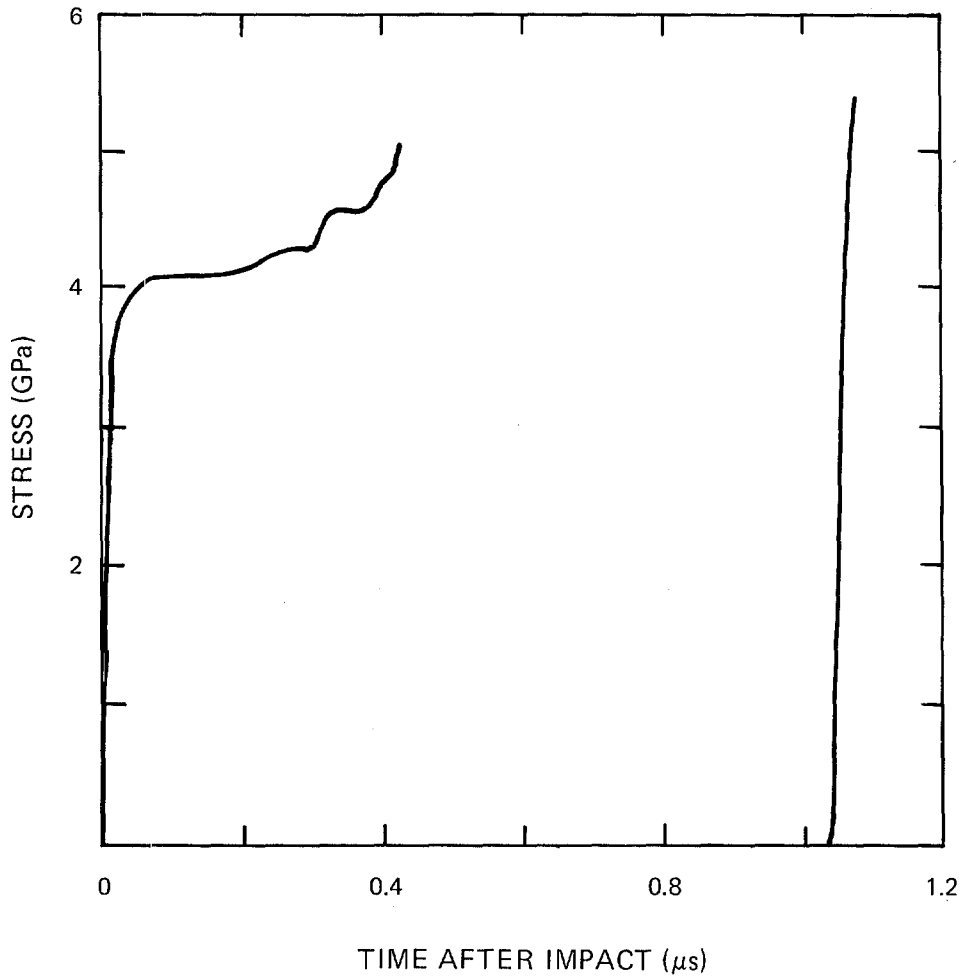

TARGET

Material: Pressed PETN
Experiment type: Quartz-gage impact face front back
Impact stress: 1.75 GPa
Experimenters: Jerry Wackerle and J. O. Johnson
Reference: Wackerle and Johnson (1973)
Shot no.: 7-12 **Series no.:** X67 **Date:** 1969
Thickness: 1.23 mm **Diameter:** 33 mm
Density: 1.71 g/cm³
 $C_L = 2.9 \text{ mm}/\mu\text{s}$ $C_S = 1.5 \text{ mm}/\mu\text{s}$
Fabrication: Specimens were dry-pressed at ambient temperature from permeametric specific surface 3000-cm²/g detonator-grade PETN

IMPACTOR

50-mm-diam aluminum alloy projectile faced with quartz gage described below
Impact velocity: 0.453 mm/ μ s

TRANSDUCERS

Impact face: Shunted guard-ring quartz gage
30-mm diam by 7.3 mm thick; 9.4-mm-diam electrode
Back face: Arrival at free surface measured with ferroelectric transducer pin
Reference: Graham, Neilson, and Benedick (1965)
Time after impact

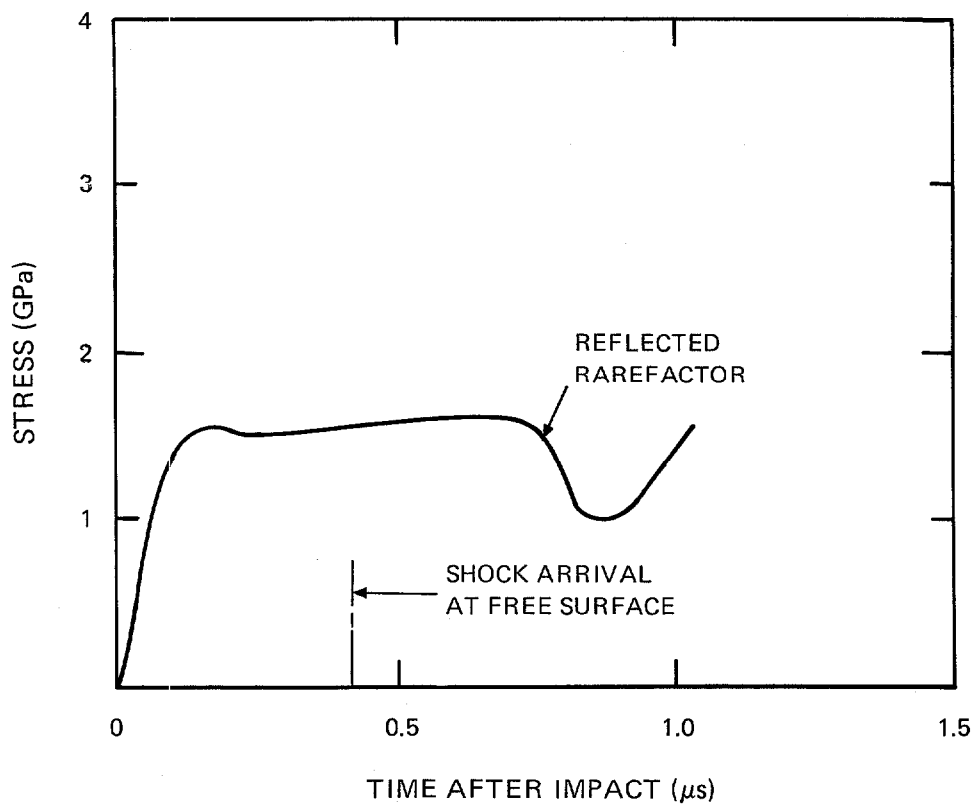

TARGET **Material:** TATB, superfine
Experiment type: Embedded Manganin gage
Experimenter: M. J. Ginsberg
Impact stress: ~7.5 GPa
Shot no.: 458 **Date:** June 20, 1980
Thickness: 12 mm **Diameter:** 51 mm
Density: 1.808 g/cm³
Fabrication technique: Hot-pressed at 50°C with 1-min dwell time.
Machined to final shape.
Note: Radiographs of samples show no appreciable density discontinuities.

IMPACTOR Annealed tough-pitch copper flyer, 6.0 mm thick, mounted on a
ZK60A magnesium alloy projectile
Impact velocity: 1.17 mm/μs

TRANSDUCER Two-terminal, 0.020-Ω Manganin gage
Distance to impact surface: 5.300 mm
Heat treatment: Annealed
Encapsulation: 0.25-mm Teflon on each side
Calibration: As described by Vantine et al.
Time: Relative
Reference: Vantine, Chan, Erickson, Janzen, Weingart, and Lee
(1980)

NOTES Shots 458, 461, 470, 473, 476, and 478 are a series with varying
target thickness and constant impact stress.

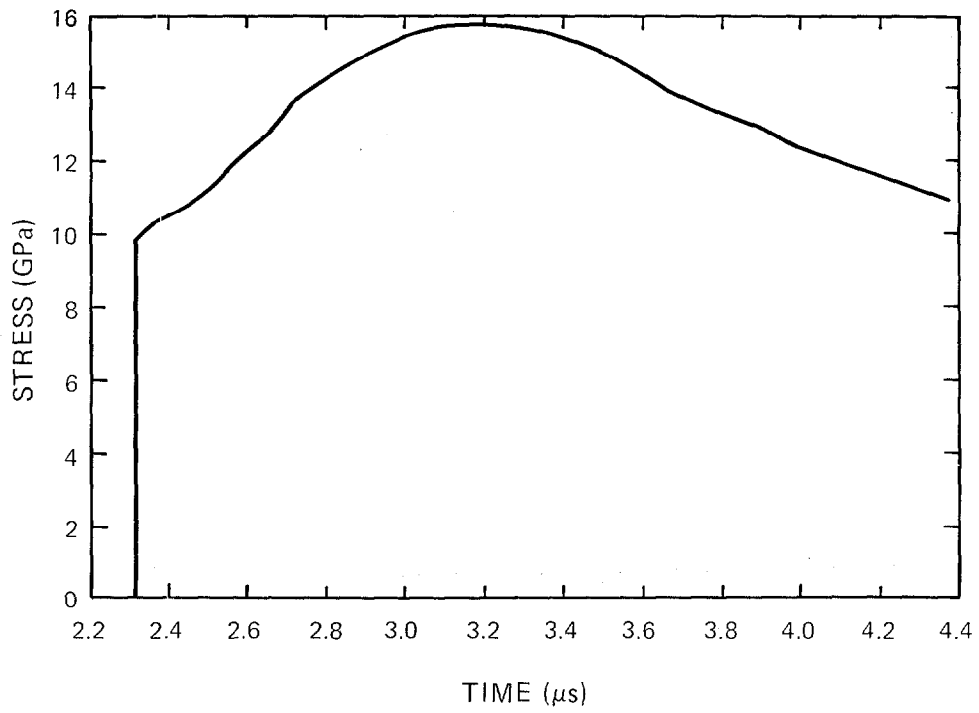

TARGET Material: TATB, superfine
Experiment type: Embedded Manganin gage
Experimenter: M. J. Ginsberg
Impact stress: ~7.5 GPa
Shot no.: 461 Date: July 16, 1980
Thickness: 12 mm Diameter: 51 mm
Density: 1.793 g/cm³
Fabrication technique: Hot-pressed at 50°C with 1-min dwell time.
Machined to final shape.
Note: Radiographs of samples show no appreciable density discontinuities.

IMPACTOR Annealed tough-pitch copper flyer, 6.0 mm thick, mounted on a
ZK60A magnesium alloy projectile
Impact velocity: 1.17 mm/μs

TRANSDUCER Two-terminal, 0.020-Ω Manganin gage
Distance to impact surface: 6.695 mm
Heat treatment: Annealed
Encapsulation: 0.25-mm Teflon on each side
Calibration: As described by Vantine et al.
Time: Relative
Reference: Vantine, Chan, Erickson, Janzen, Weingart, and Lee
(1980)

NOTES Shots 458, 461, 470, 473, 476, and 478 are a series with varying
target thickness and constant impact stress.

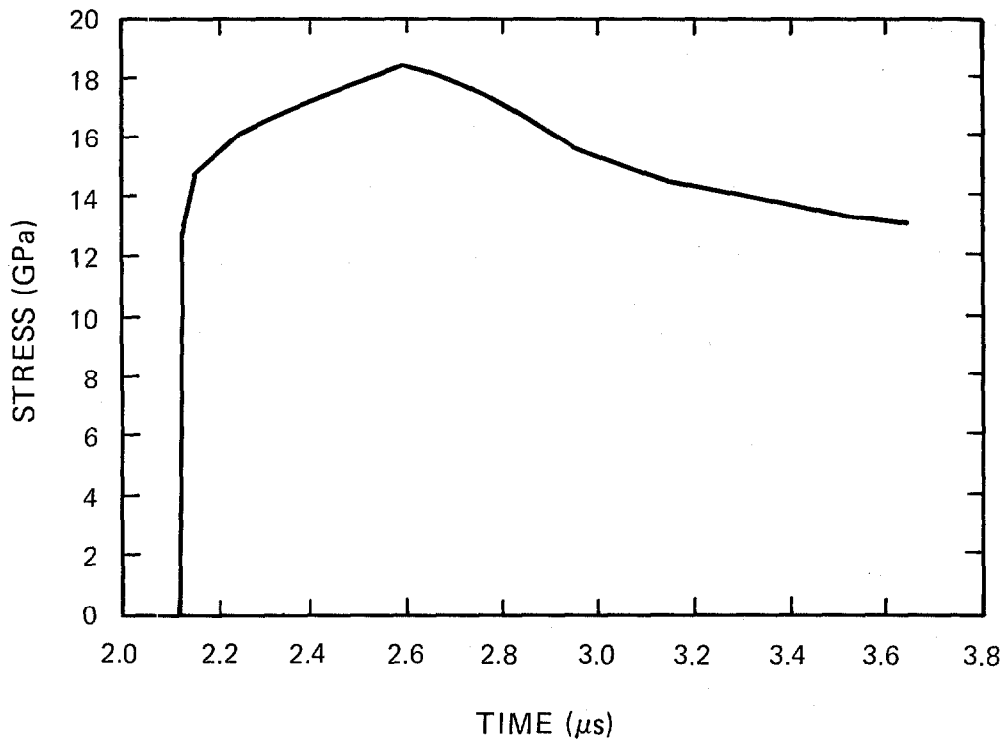

TARGET **Material:** TATB, superfine
Experiment type: Embedded Manganin gage
Experimenter: M. J. Ginsberg
Impact stress: ~7.5 GPa
Shot no.: 470 **Date:** August 25, 1980
Thickness: 10 mm **Diameter:** 51 mm
Density: 1.880 g/cm³
Fabrication technique: Hot-pressed at 50°C with 1-min dwell time.
Machined to final shape.
Note: Radiographs of samples show no appreciable density discontinuities.

IMPACTOR Annealed tough-pitch copper flyer, 6.0 mm thick, mounted on a
ZK60A magnesium alloy projectile
Impact velocity: 1.17 mm/μs

TRANSDUCER Two-terminal, 0.020-Ω Manganin gage
Distance to impact surface: 2.285 mm
Heat treatment: Annealed
Encapsulation: 0.25-mm Teflon on each side
Calibration: As described by Vantine et al.
Time: Relative
Reference: Vantine, Chan, Erickson, Janzen, Weingart, and Lee
(1980)

NOTES Shots 458, 461, 470, 473, 476, and 478 are a series with varying
target thickness and constant impact stress.

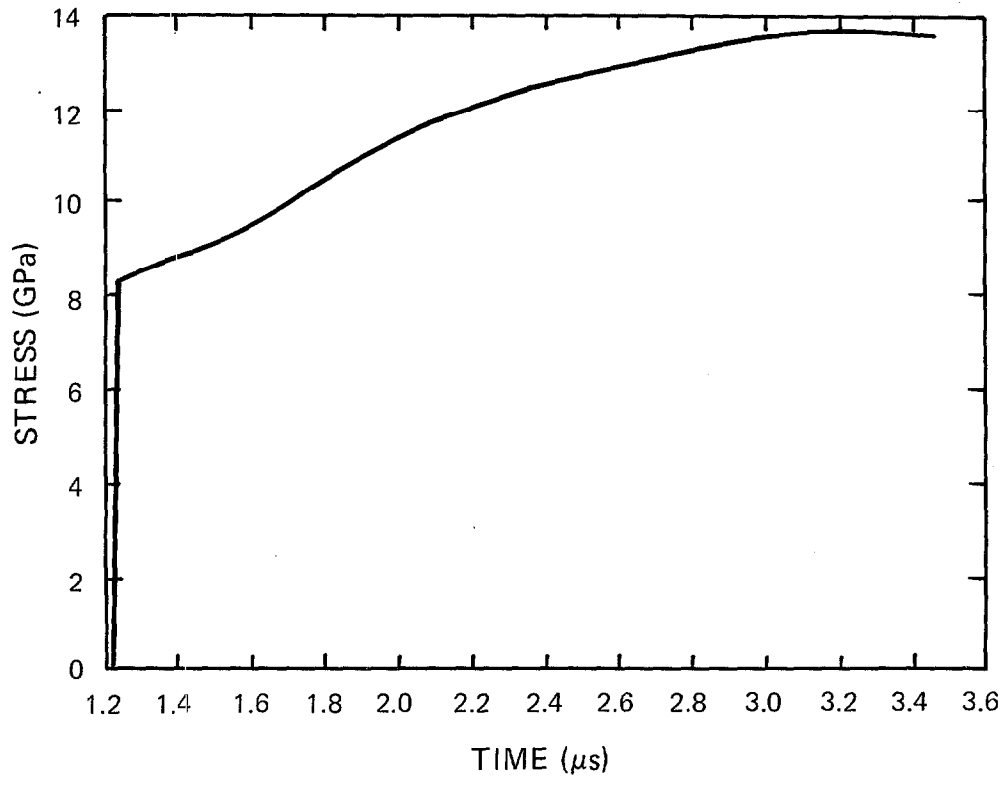

TARGET **Material:** TATB, superfine
Experiment type: Embedded Manganin gage
Experimenter: M. J. Ginsberg
Impact stress: ~7.5 GPa
Shot no.: 473 **Date:** September 4, 1980
Thickness: 10 mm **Diameter:** 51 mm
Density: 1.796 g/cm³
Fabrication technique: Hot-pressed at 50°C with 1-min dwell time.
Machined to final shape.
Note: Radiographs of samples show no appreciable density discontinuities.

IMPACTOR Annealed tough-pitch copper flyer, 6.0 mm thick, mounted on a
ZK60A magnesium alloy projectile
Impact velocity: 1.17 mm/μs

TRANSDUCER Two-terminal, 0.020-Ω Manganin gage
Distance to impact surface: 3.725 mm
Heat treatment: Annealed
Encapsulation: 0.25-mm Teflon on each side
Calibration: As described by Vantine et al.
Time: Relative
Reference: Vantine, Chan, Erickson, Janzen, Weingart, and Lee
(1980)

NOTES Shots 458, 461, 470, 473, 476, and 478 are a series with varying
target thickness and constant impact stress.

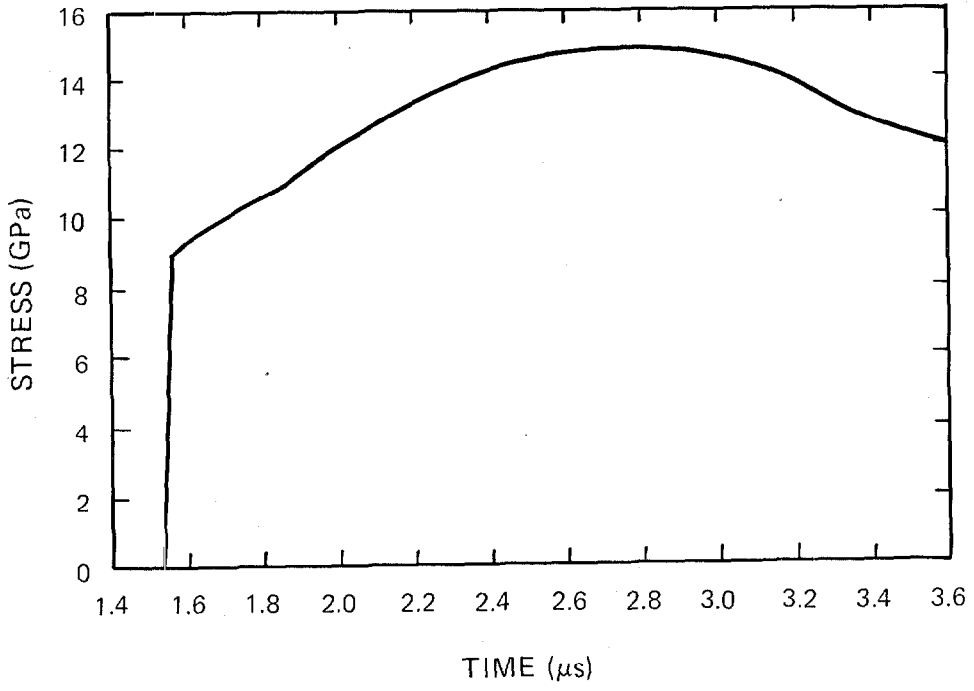

TARGET

Material: TATB, superfine

Experiment type: Embedded Manganin gage, short shock case

Experimenter: M. J. Ginsberg

Impact stress: ~7.4 GPa

Shot no.: 474 **Date:** September 5, 1980

Thickness: 10 mm **Diameter:** 51 mm

Density: 1.800 g/cm³

Fabrication technique: Hot-pressed at 50°C with 1-min dwell time.
Machined to final shape.

Note: Radiographs of samples show no appreciable density discontinuities.

IMPACTOR

Annealed tough-pitch copper flyer, 1.00 mm thick, mounted on a ZK60A magnesium alloy projectile

Impact velocity: 1.16 mm/μs

TRANSDUCER

Two-terminal, 0.020-Ω Manganin gage

Distance to impact surface: 2.285 mm

Heat treatment: Annealed

Encapsulation: 0.25-mm Teflon on each side

Calibration: As described by Vantine et al.

Time: Relative

Reference: Vantine, Chan, Erickson, Janzen, Weingart, and Lee (1980)

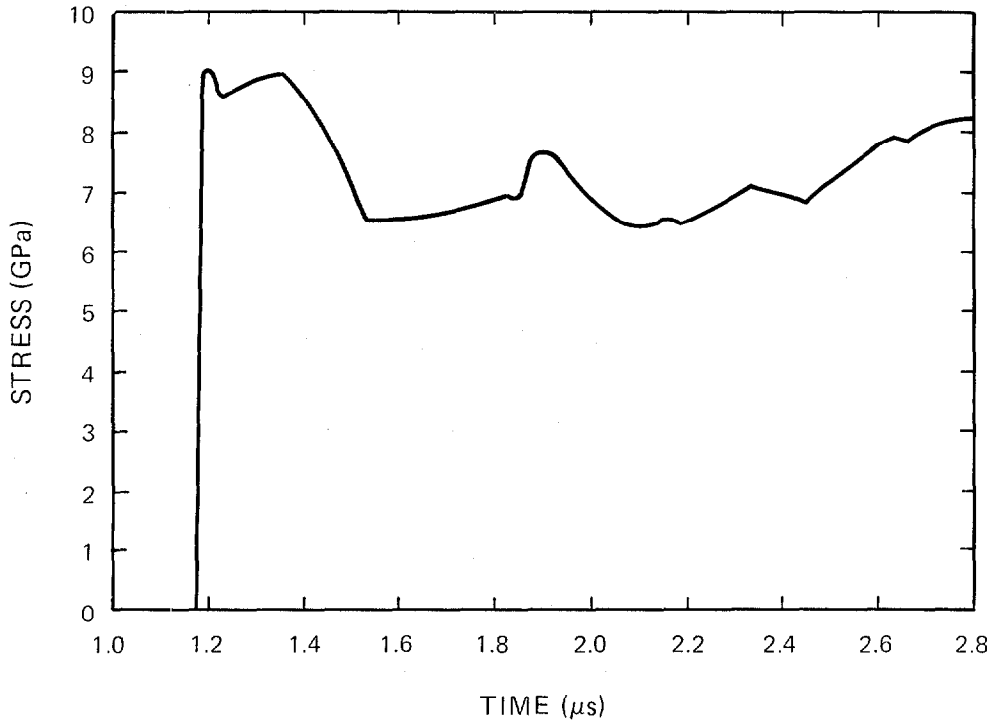

TARGET **Material:** TATB, superfine
Experiment type: Embedded Manganin gage
Experimenter: M. J. Ginsberg
Impact stress: ~7.5 GPa
Shot no.: 476 **Date:** September 23, 1980
Thickness: 8 mm **Diameter:** 51 mm
Density: 1.799 g/cm³
Fabrication technique: Hot-pressed at 50°C with 1-min dwell time.
Machined to final shape.
Note: Radiographs of samples show no appreciable density discontinuities.

IMPACTOR **Annealed tough-pitch copper flyer, 6.0 mm thick, mounted on a ZK60A magnesium alloy projectile**
Impact velocity: 1.18 mm/μs

TRANSDUCER **Two-terminal, 0.020-Ω Manganin gage**
Distance to impact surface: 0 mm
Heat treatment: Annealed
Encapsulation: 0.25-mm Teflon on each side
Calibration: As described by Vantine et al.
Time: Relative
Reference: Vantine, Chan, Erickson, Janzen, Weingart, and Lee (1980)

NOTES **Shots 458, 461, 470, 473, 476, and 478 are a series with varying target thickness and constant impact stress.**

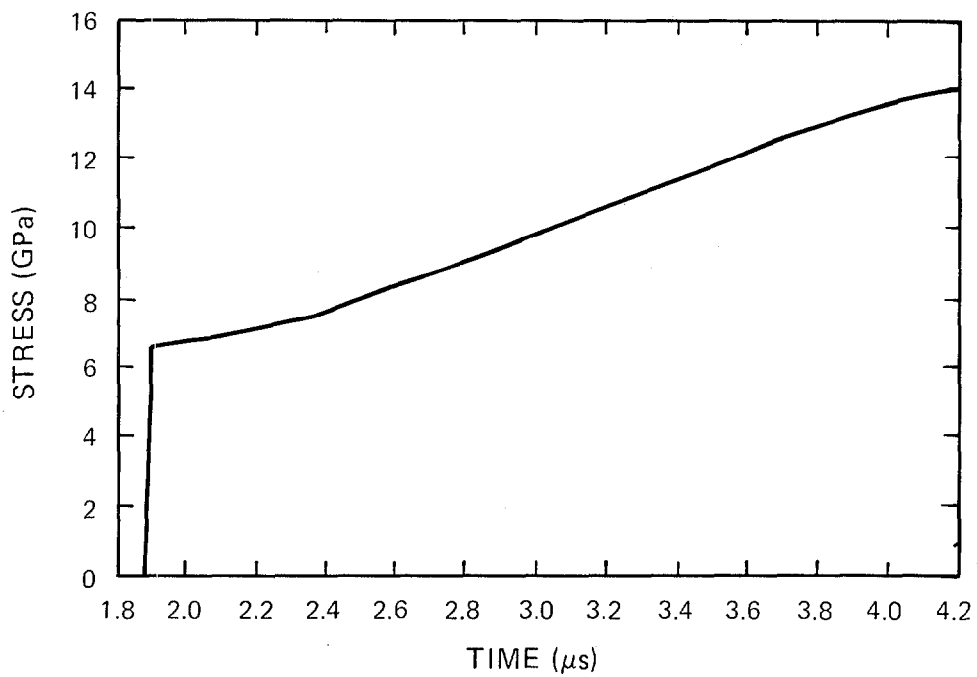

TARGET **Material:** TATB, superfine
Experiment type: Embedded Manganin gage
Experimenter: M. J. Ginsberg
Impact stress: ~7.6 GPa
Shot no.: 478 **Date:** September 25, 1980
Thickness: 14 mm **Diameter:** 51 mm
Density: 1.800 g/cm³
Fabrication technique: Hot-pressed at 50°C with 1-min dwell time.
Machined to final shape.
Note: Radiographs of samples show no appreciable density discontinuities.

IMPACTOR Annealed tough-pitch copper flyer, 6.0 mm thick, mounted on a
ZK60A magnesium alloy projectile
Impact velocity: 1.19 mm/μs

TRANSDUCER Two-terminal, 0.020-Ω Manganin gage
Distance to impact surface: 7.715 mm
Heat treatment: Annealed
Encapsulation: 0.25-mm Teflon on each side
Calibration: As described by Vantine et al.
Time: Relative
Reference: Vantine, Chan, Erickson, Janzen, Weingart, and Lee
(1980)

NOTES Shots 458, 461, 470, 473, 476, and 478 are a series with varying
target thickness and constant impact stress.

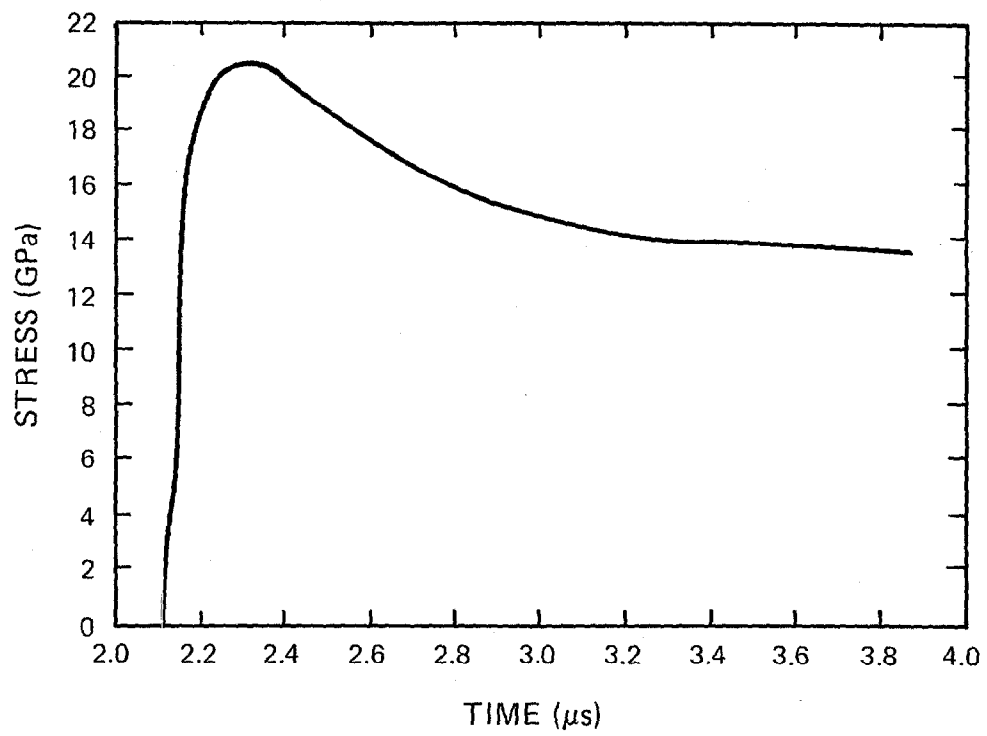

TARGET

Material: TATB, superfine

Experiment type: Embedded Manganin gage, short shock case

Experimenter: M. J. Ginsberg

Impact stress: ~7.5 GPa

Shot no.: 479 **Date:** September 26, 1980

Thickness: 10 mm **Diameter:** 51 mm

Density: 1.800 g/cm³

Fabrication technique: Hot-pressed at 50°C with 1-min dwell time.

Machined to final shape.

Note: Radiographs of samples show no appreciable density discontinuities.

IMPACTOR

Annealed tough-pitch copper flyer, 1.00 mm thick, mounted on a ZK60A magnesium alloy projectile

Impact velocity: 1.17 mm/ μ s

TRANSDUCER

Two-terminal, 0.020- Ω Manganin gage

Distance to impact surface: 3.715 mm

Heat treatment: Annealed

Encapsulation: 0.25-mm Teflon on each side

Calibration: As described by Vantine et al.

Time: Relative

Reference: Vantine, Chan, Erickson, Janzen, Weingart, and Lee (1980)

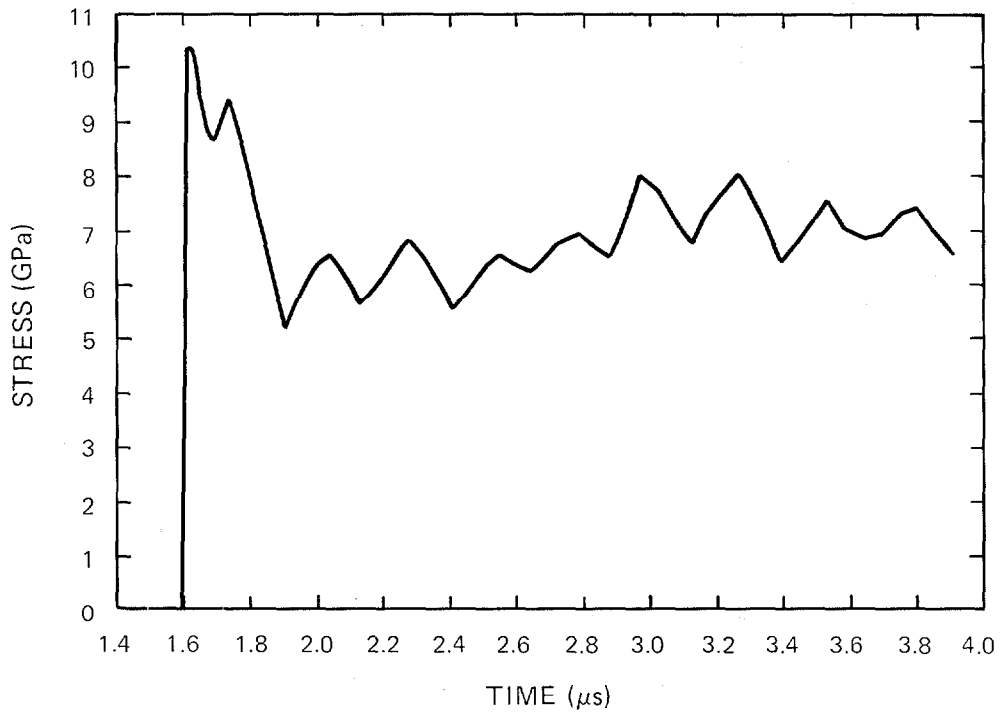

TARGET

Material: TATB, superfine

Experiment type: Embedded Manganin gage; short shock case

Experimenter: M. J. Ginsberg

Impact stress: ~7.6 GPa

Shot no.: 480 **Date:** October 3, 1980

Thickness: 14 mm **Diameter:** 51 mm

Density: 1.798 g/cm³

Fabrication technique: Hot-pressed at 50°C with 1-min dwell time.

Machined to final shape.

Note: Radiographs of samples show no appreciable density discontinuities.

IMPACTOR

Annealed tough-pitch copper flyer, 1.00 mm thick, mounted on a ZK60A magnesium alloy projectile

Impact velocity: 1.19 mm/μs

TRANSDUCER

Two-terminal, 0.020-Ω Manganin gage

Distance to impact surface: 7.735 mm

Heat treatment: Annealed

Encapsulation: 0.25-mm Teflon on each side

Calibration: As described by Vantine et al.

Time: Relative

Reference: Vantine, Chan, Erickson, Janzen, Weingart, and Lee (1980)

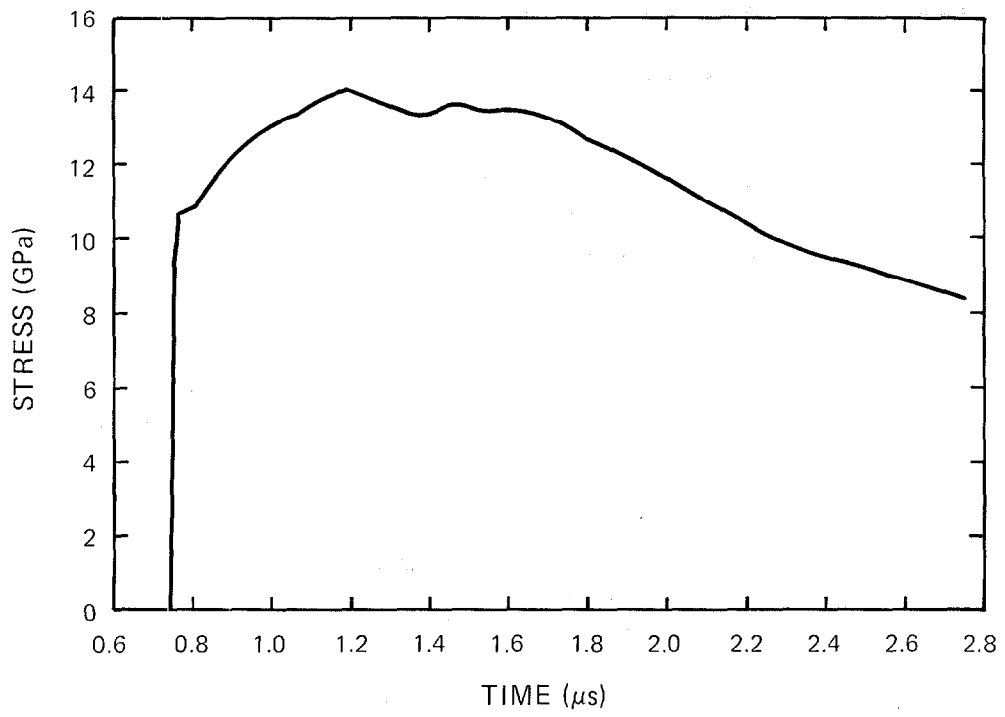

TARGET

Material: TATB, superfine
Experiment type: Embedded Manganin gage; short shock case
Experimenter: M. J. Ginsberg
Impact stress: ~ 7.4 GPa
Shot no.: 483 **Date:** October 22, 1980
Thickness: 12 mm **Diameter:** 51 mm
Density: 1.798 g/cm³
Fabrication technique: Hot-pressed at 50°C with 1-min dwell time.
Machined to final shape.
Note: Radiographs of samples show no appreciable density discontinuities.

IMPACTOR

Annealed tough-pitch copper flyer, 1.00 mm thick, mounted on a ZK60A magnesium alloy projectile
Impact velocity: 1.15 mm/ μ s

TRANSDUCER

Two-terminal, 0.040- Ω Manganin gage
Distance to impact surface: 5.665 mm
Heat treatment: Annealed
Encapsulation: 0.25-mm Teflon on each side
Calibration: As described by Vantine et al.
Time: Relative
Reference: Vantine, Chan, Erickson, Janzen, Weingart, and Lee (1980)

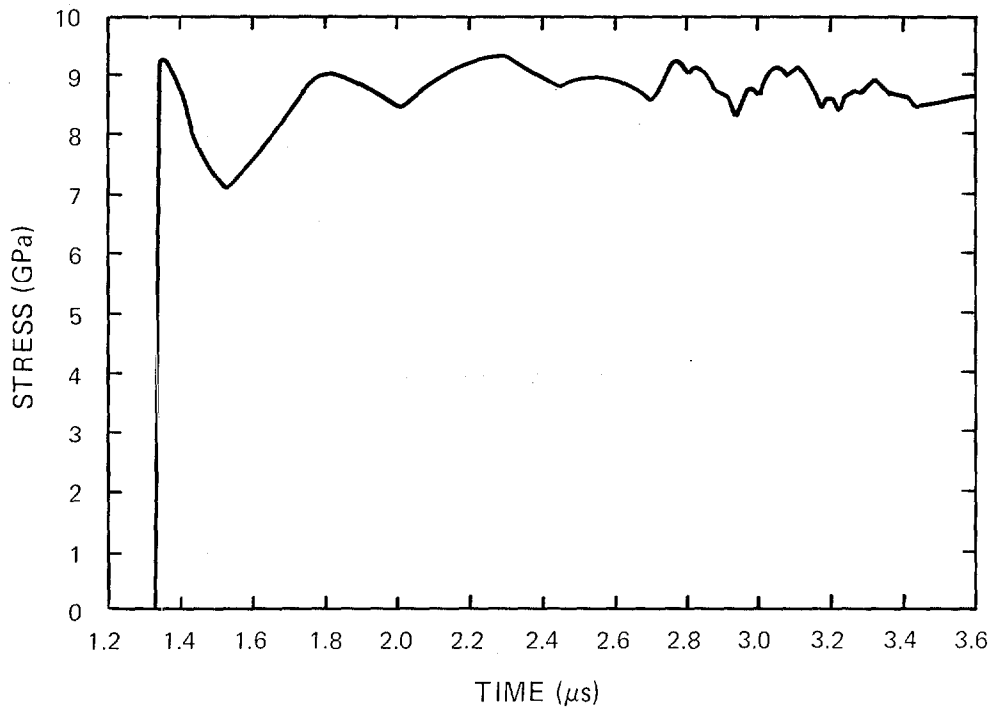

TARGET**Material:** TNT**Experiment type:** Embedded Manganin gage**Experimenter:** Bart Olinger**Shot no.:** 56-77-102 **Date:** October 25, 1977**Diameter:** 38.1 mm**Density:** 1.63 g/cm³**C_L** = 2.68 mm/μs **C_s** = 1.35 mm/μs**IMPACTOR**TNT, 3.05 mm thick, backed with low-density polyurethane foam,
mounted on 51-mm-diam aluminum alloy projectile**Impact velocity:** 0.294 mm/μs**TRANSDUCER**

Two-terminal, 50-Ω Manganin gage

Locations from impact surface: 2.04 mm, 6.11 mm, and 10.18 mm**Heat treatment:** Annealed**Encapsulation:** None**Calibration:** J. W. Hopson and J. W. Taylor calibration formula
for Manganin gages

$$\sigma = a_1 x + b_1 x^2 + c_1 x^3 \text{ for } x < 0.1,$$

$$\sigma = a_2 + b_2 x + c_2 x^2 \text{ for } x > 0.1,$$

where $x = \Delta R/R$.

$$a_1 = 521.32 \quad b_1 = -1614.86 \quad c_1 = 7648.72$$

$$a_2 = 6.5950 \quad b_2 = 370.37 \quad c_2 = 0.00$$

Time: Relative

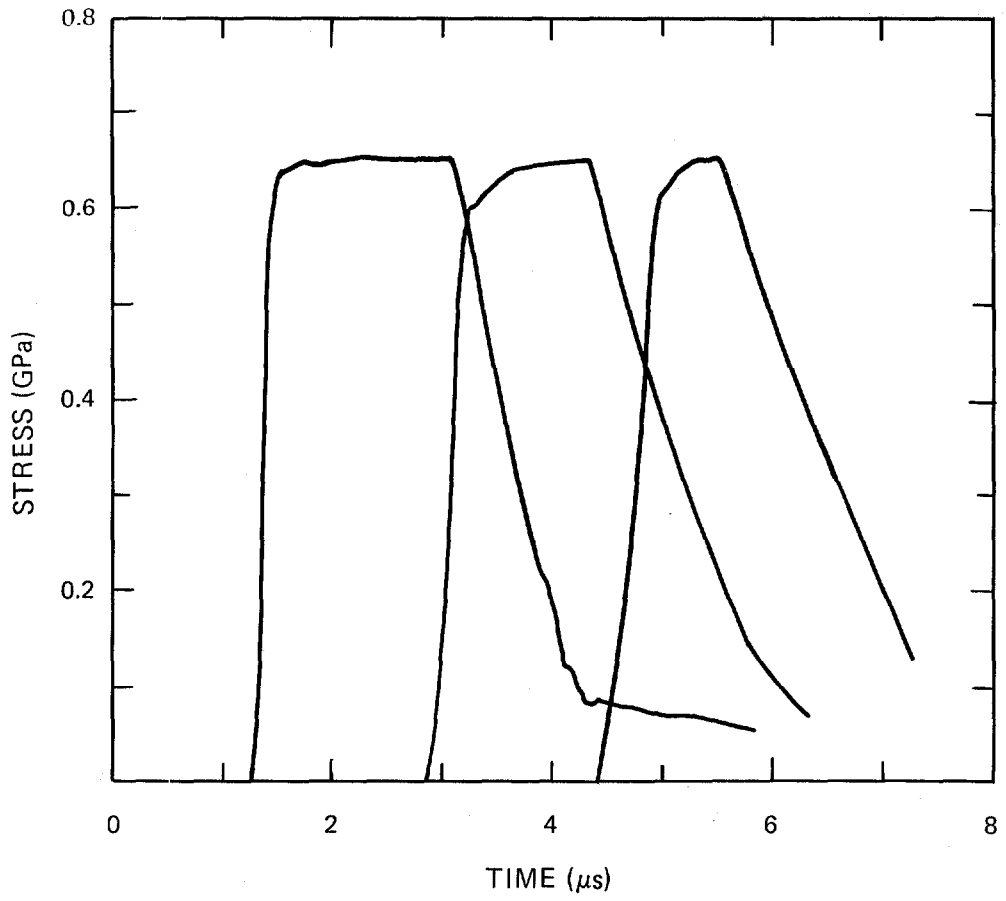

TARGET **Material:** TP-N1028 Class VII propellant
Experiment type: Embedded Manganin gage
Experimenter: Bart Olinger
Shot no.: 56-78-23 **Date:** June 9, 1978
Diameter: 38.1 mm
Density: 1.846 g/cm³
C_L = 2.36 mm/μs **C_S** = 0.35 mm/μs

IMPACTOR PMMA, 4.00 mm thick, backed with low-density polyurethane foam,
mounted on 51-mm-diam aluminum alloy projectile
Impact velocity: 0.27 mm/μs

TRANSDUCER Two-terminal, 50-Ω Manganin gage
Locations from impact surface: 1.07 mm, 4.06 mm, and 7.05 mm
Heat treatment: Annealed
Encapsulation: None
Calibration: J. W. Hopson and J. W. Taylor calibration formula
for Manganin gages
 $\sigma = a_1 x + b_1 x^2 + c_1 x^3$ for $x < 0.1$,
 $\sigma = a_2 + b_2 x + c_2 x^2$ for $x > 0.1$,
where $x = \Delta R/R$.
a₁ = 521.32 **b₁** = -1614.86 **c₁** = 7648.72
a₂ = 6.5950 **b₂** = 370.37 **c₂** = 0.00
Time: Relative

NOTES The first disk in the layered target was 1.07-mm-thick PMMA. The
other disks were propellant.

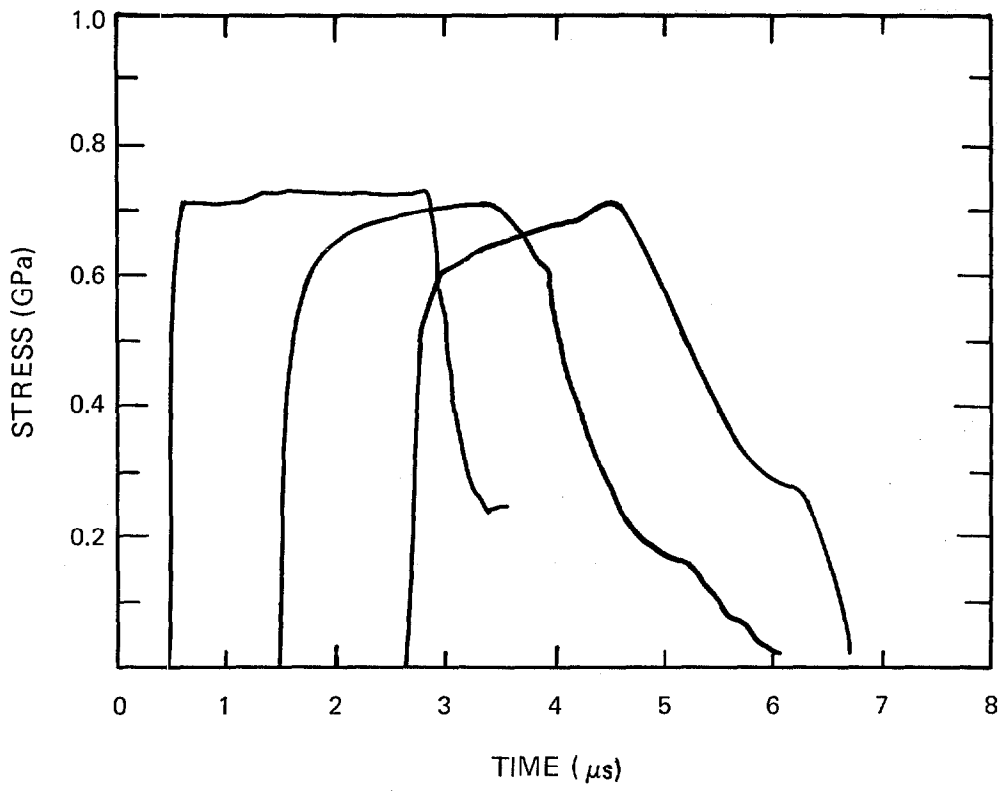

TARGET

Material: TP-N1028 Class VII propellant
Experiment type: Embedded Manganin gage
Experimenter: Bart Olinger
Shot no.: 56-78-26 Date: June 23, 1978
Diameter: 38.1 mm
Density: 1.846 g/cm³
 $C_L = 2.36$ mm/ μ s $C_S = 0.35$ mm/ μ s

IMPACTOR

PMMA, 4.00 mm thick, backed with low-density polyurethane foam,
mounted on 51-mm-diam aluminum alloy projectile
Impact velocity: 0.18 mm/ μ s

TRANSDUCER

Two-terminal, 50- Ω Manganin gage
Locations from impact surface: 2.04 mm, 5.02 mm, and 8.03 mm
Heat treatment: Annealed
Encapsulation: None
Calibration: J. W. Hopson and J. W. Taylor calibration formula
for Manganin gages
 $\sigma = a_1 x + b_1 x^2 + c_1 x^3$ for $x < 0.1$,
 $\sigma = a_2 + b_2 x + c_2 x^2$ for $x > 0.1$,
where $x = \Delta R/R$.
 $a_1 = 521.32$ $b_1 = -1614.86$ $c_1 = 7648.72$
 $a_2 = 6.5950$ $b_2 = 370.37$ $c_2 = 0.00$
Time: Relative

NOTES

The first disk in the layered target was 2.04-mm-thick PMMA. The
other disks were propellant.

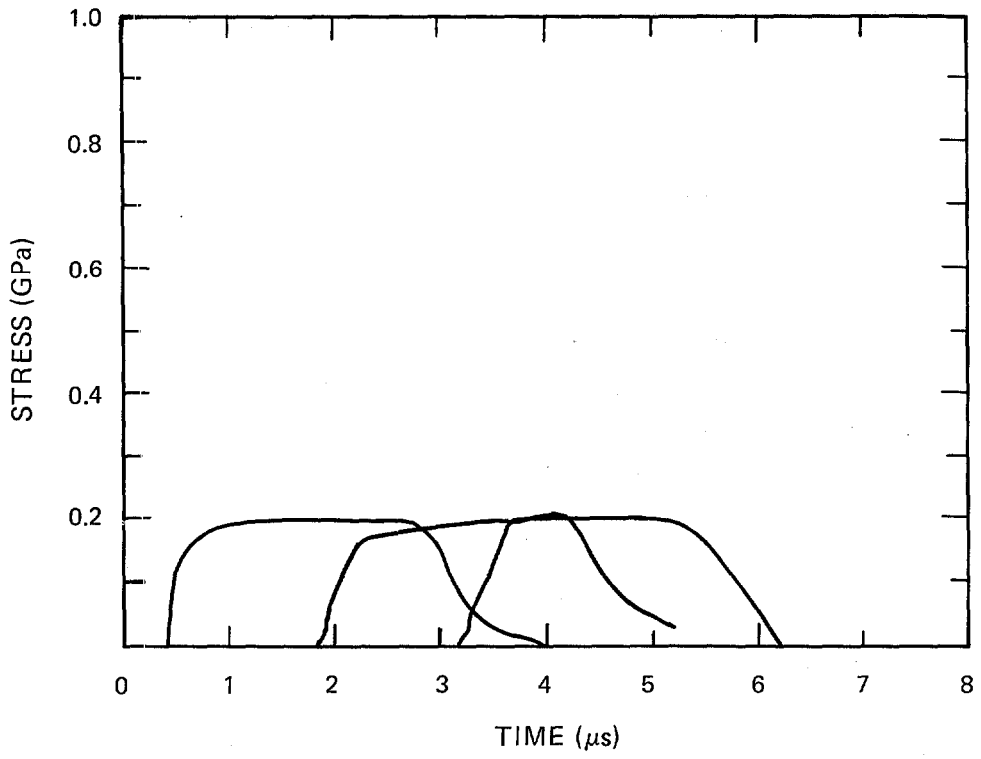

TARGET

Material: TP-N1028 Class VII propellant
Experiment type: Embedded Manganin gage
Experimenter: Bart Olinger
Shot no.: 56-78-33 **Date:** June 28, 1978
Diameter: 38.1 mm
Density: 1.846 g/cm³
 $C_L = 2.36$ mm/ μ s $C_s = 0.35$ mm/ μ s

IMPACTOR

PMMA, 4.00 mm thick, backed with low-density polyurethane foam, mounted on 51-mm-diam aluminum alloy projectile
Impact velocity: 0.41 mm/ μ s

TRANSDUCER

Two-terminal, 50- Ω Manganin gage
Locations from impact surface: 2.06 mm, 5.04 mm, and 8.05 mm
Heat treatment: Annealed
Encapsulation: None
Calibration: J. W. Hopson and J. W. Taylor calibration formula for Manganin gages
 $\sigma = a_1 x + b_1 x^2 + c_1 x^3$ for $x < 0.1$,
 $\sigma = a_2 + b_2 x + c_2 x^2$ for $x > 0.1$,
where $x = \Delta R/R$.
 $a_1 = 521.32$ $b_1 = -1614.86$ $c_1 = 7648.72$
 $a_2 = 6.5950$ $b_2 = 370.37$ $c_2 = 0.00$
Time: Relative

NOTES

The first disk in the layered target was 2.06-mm-thick PMMA. The other disks were propellant.

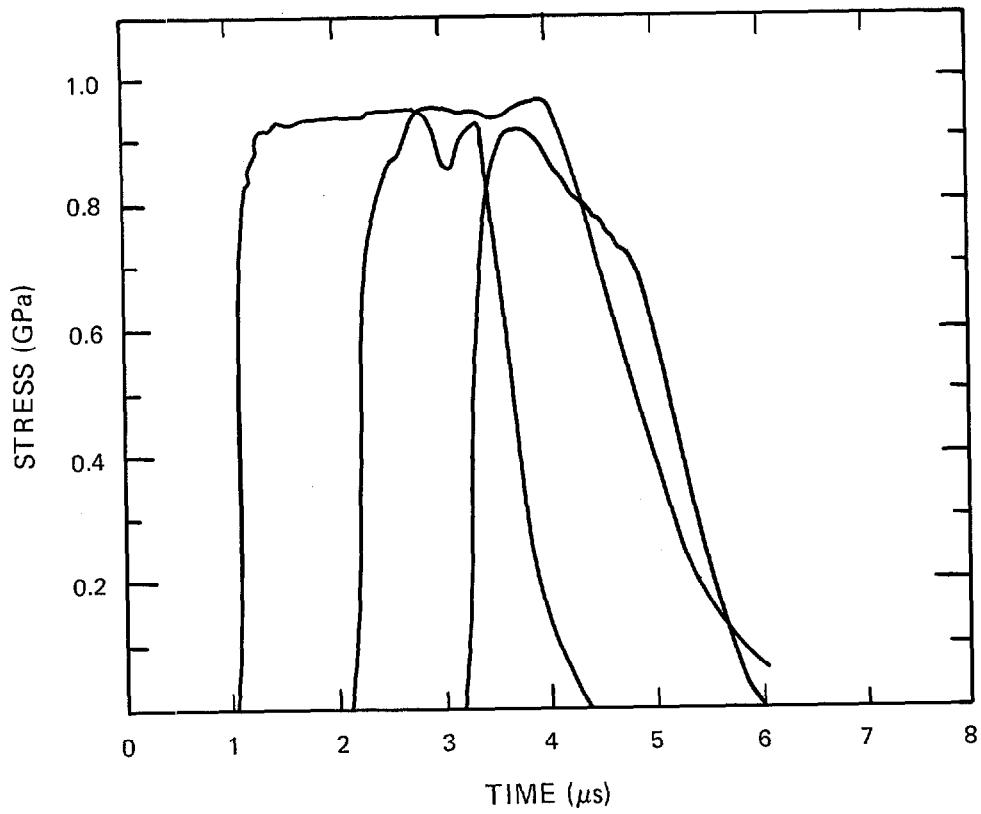

TARGET

Material: UTP-20930 Class VII propellant
Experiment type: Embedded Manganin gage
Experimenter: Bart Olinger
Shot no.: 56-78-24 Date: June 9, 1978
Diameter: 38.1 mm
Density: 1.838 g/cm³
 $C_L = 2.61$ mm/ μ s $C_S = 0.41$ mm/ μ s

IMPACTOR

PMMA, 4.00 mm thick, backed with low-density polyurethane foam,
mounted on 51-mm-diam aluminum alloy projectile
Impact velocity: 0.26 mm/ μ s

TRANSDUCER

Two-terminal, 50- Ω Manganin gage
Locations from impact surface: 1.07 mm, 4.04 mm, and 7.04 mm
Heat treatment: Annealed
Encapsulation: None
Calibration: J. W. Hopson and J. W. Taylor calibration formula
for Manganin gages
 $\sigma = a_1 x + b_1 x^2 + c_1 x^3$ for $x < 0.1$,
 $\sigma = a_2 + b_2 x + c_2 x^2$ for $x > 0.1$,
where $x = \Delta R/R$.
 $a_1 = 521.32$ $b_1 = -1614.86$ $c_1 = 7648.72$
 $a_2 = 6.5950$ $b_2 = 370.37$ $c_2 = 0.00$
Time: Relative

NOTES

The first disk in the layered target was 1.07-mm-thick PMMA. The other disks were propellant.

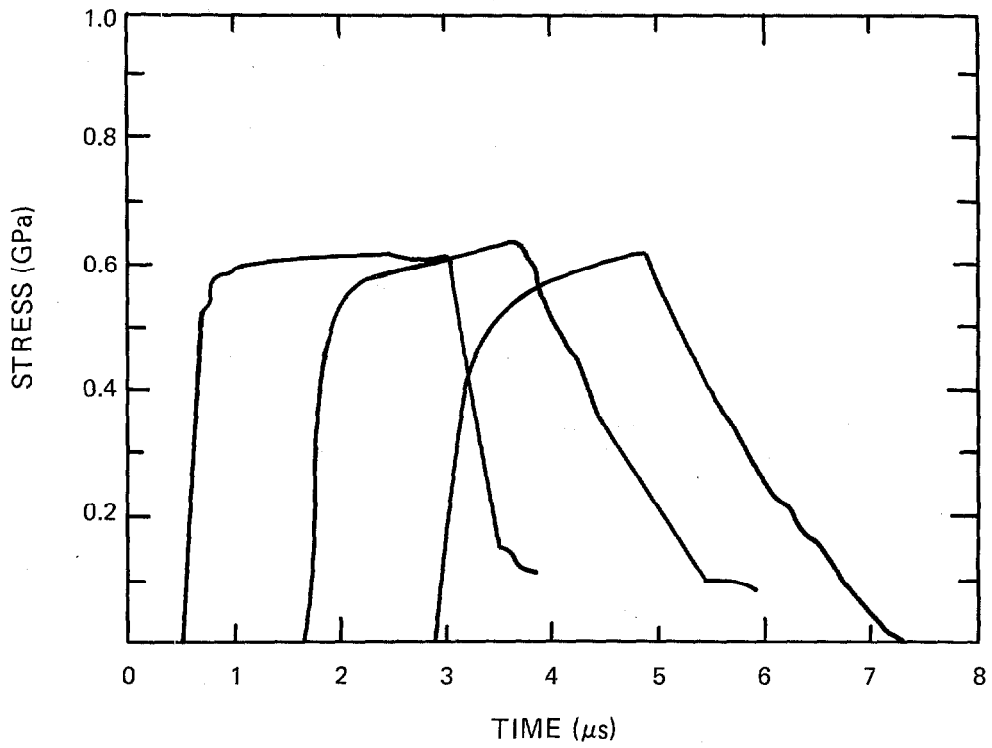

TARGET

Material: UTP-20930 Class VII propellant
Experiment type: Embedded Manganin gage
Experimenter: Bart Olinger
Shot no.: 56-78-25 **Date:** June 23, 1978
Diameter: 38.1 mm
Density: 1.838 g/cm³
C_L = 2.61 mm/μs **C_S** = 0.41 mm/μs

IMPACTOR

PMMA, 4.00 mm thick, backed with low-density polyurethane foam, mounted on 51-mm-diam aluminum alloy projectile
Impact velocity: 0.16 mm/μs

TRANSDUCER

Two-terminal, 50-Ω Manganin gage
Locations from impact surface: 5.06 mm and 8.06 mm
Heat treatment: Annealed
Encapsulation: None
Calibration: J. W. Hopson and J. W. Taylor calibration formula for Manganin gages
 $\sigma = a_1 x + b_1 x^2 + c_1 x^3$ for $x < 0.1$,
 $\sigma = a_2 + b_2 x + c_2 x^2$ for $x > 0.1$,
where $x = \Delta R/R$.
 $a_1 = 521.32$ $b_1 = -1614.86$ $c_1 = 7648.72$
 $a_2 = 6.5950$ $b_2 = 370.37$ $c_2 = 0.00$
Time: Relative

NOTES

The first disk in the layered target was 2.06-mm-thick PMMA. The other disks were propellant.

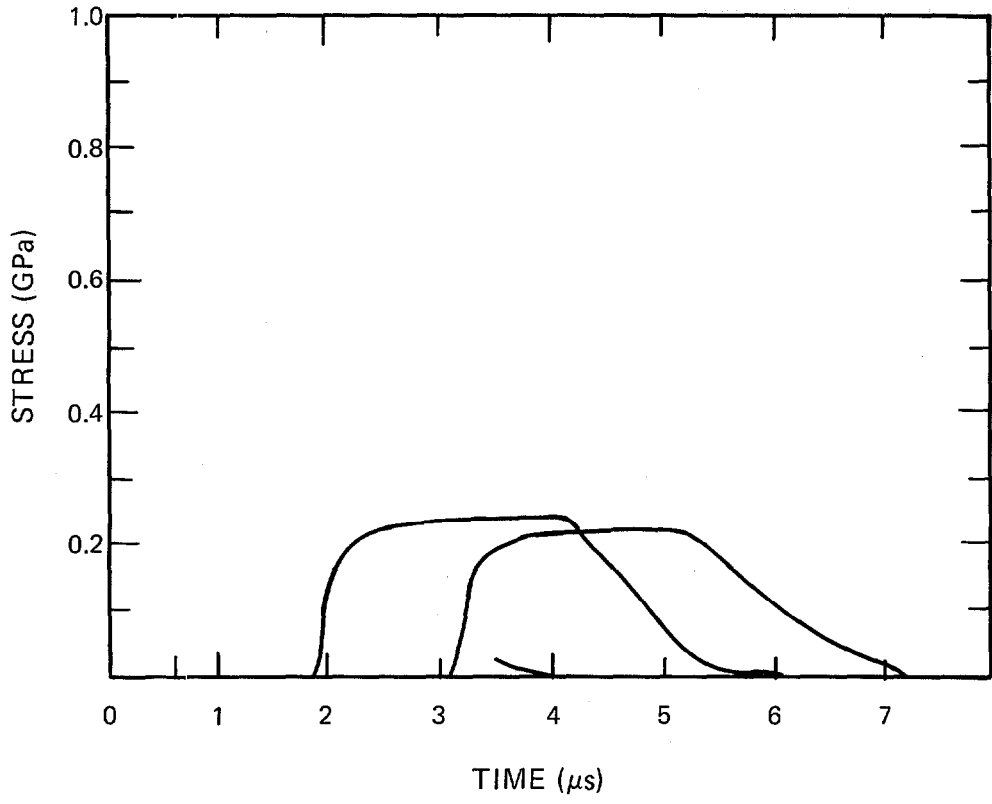

TARGET

Material: UTP-20930 Class VII propellant
Experiment type: Embedded Manganin gage
Experimenter: Bart Olinger
Shot no.: 56-78-32 **Date:** June 27, 1978
Diameter: 38.1 mm
Density: 1.838 g/cm³
 $C_L = 2.61$ mm/ μ s $C_S = 0.41$ mm/ μ s

IMPACTOR

PMMA, 4.00 mm thick, backed with low-density polyurethane foam, mounted on 51-mm-diam aluminum alloy projectile
Impact velocity: 0.39 mm/ μ s

TRANSDUCER

Two-terminal, 50- Ω Manganin gage
Locations from impact surface: 2.06 mm, 5.08 mm, and 8.06 mm
Heat treatment: Annealed
Encapsulation: None
Calibration: J. W. Hopson and J. W. Taylor calibration formula for Manganin gages
 $\sigma = a_1 x + b_1 x^2 + c_1 x^3$ for $x < 0.1$,
 $\sigma = a_2 + b_2 x + c_2 x^2$ for $x > 0.1$,
where $x = \Delta R/R$.
 $a_1 = 521.32$ $b_1 = -1614.86$ $c_1 = 7648.72$
 $a_2 = 6.5950$ $b_2 = 370.37$ $c_2 = 0.00$
Time: Relative

NOTES

The first disk in the layered target was 2.06-mm-thick PMMA. The other disks were propellant.

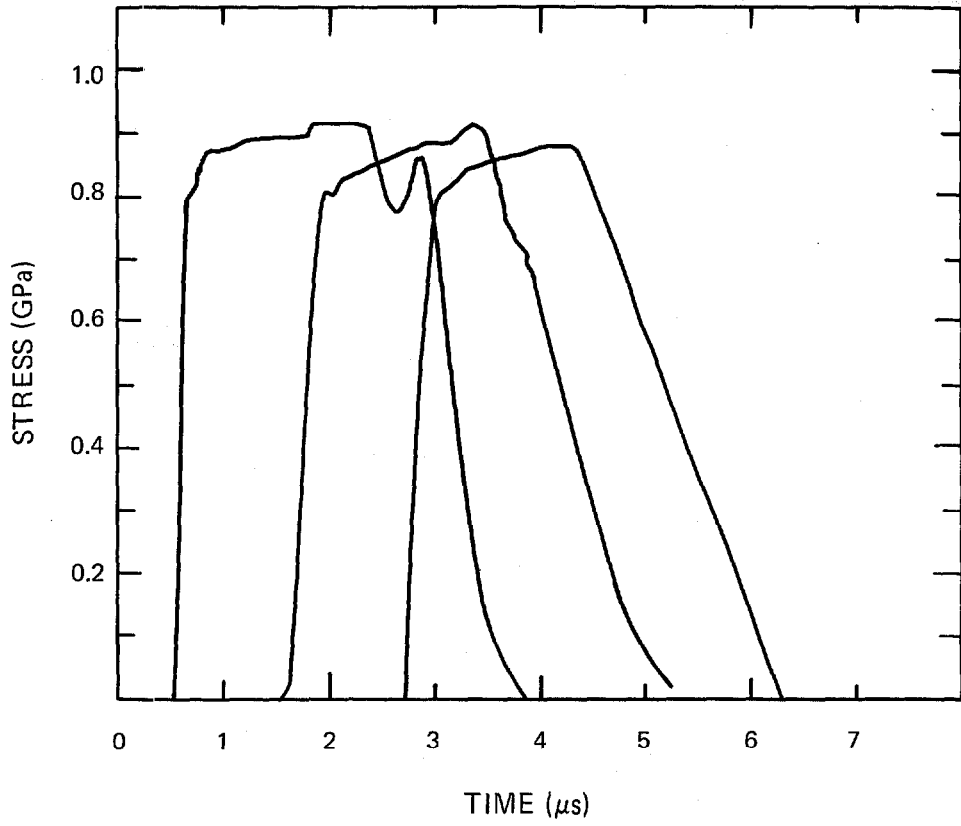

TARGET

Material: VWC-2 Class VII propellant
Experiment type: Embedded Manganin gage
Experimenter: Bart Olinger
Shot no.: 56-78-22 Date: June 9, 1978
Diameter: 38.1 mm
Density: 1.835 g/cm³
 $C_L = 2.13$ mm/ μ s $C_S = 0.49$ mm/ μ s

IMPACTOR

PMMA, 4.00 mm thick, backed with low-density polyurethane foam,
mounted on 51-mm-diam aluminum alloy projectile
Impact velocity: 0.29 mm/ μ s

TRANSDUCER

Two-terminal, 50- Ω Manganin gage
Locations from impact surface: 1.07 mm, 4.04 mm, and 7.01 mm
Heat treatment: Annealed
Encapsulation: None
Calibration: J. W. Hopson and J. W. Taylor calibration formula
for Manganin gages
 $\sigma = a_1 x + b_1 x^2 + c_1 x^3$ for $x < 0.1$,
 $\sigma = a_2 + b_2 x + c_2 x^2$ for $x > 0.1$,
where $x = \Delta R/R$.
 $a_1 = 521.32$ $b_1 = -1614.86$ $c_1 = 7648.72$
 $a_2 = 6.5950$ $b_2 = 370.37$ $c_2 = 0.00$
Time: Relative

NOTES

The first disk in the layered target was 1.07-mm-thick PMMA. The
other disks were propellant.

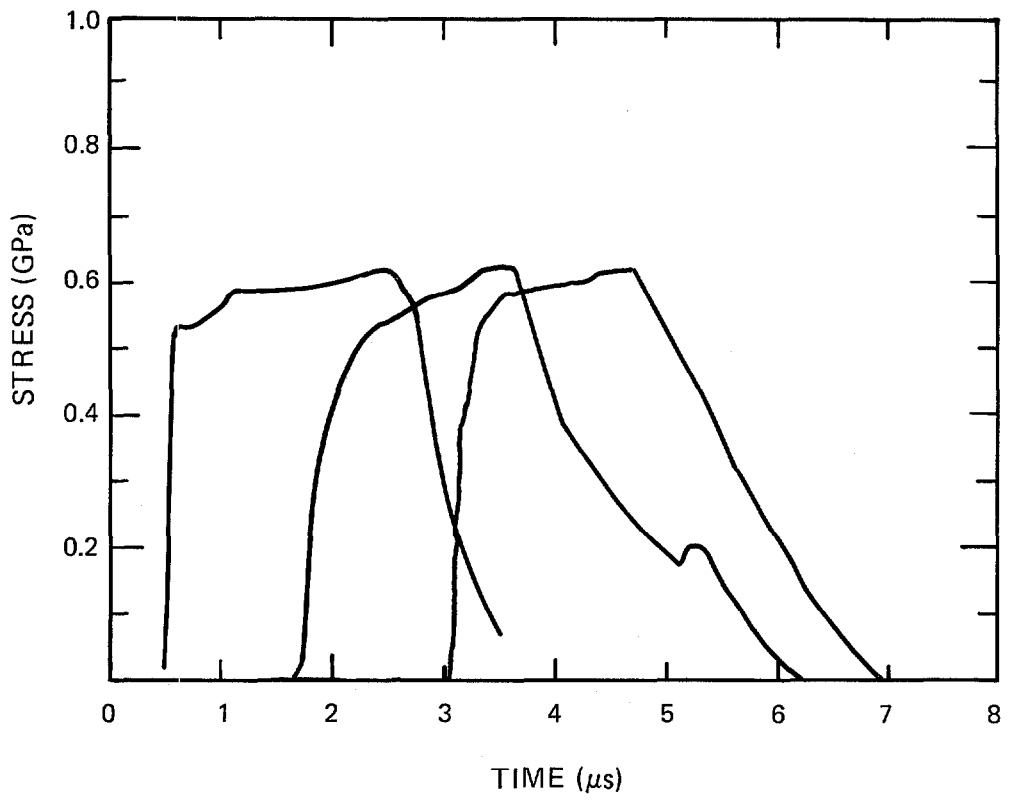

TARGET

Material: VWC-2 Class VII propellant
Experiment type: Embedded Manganin gage
Experimenter: Bart Olinger
Shot no.: 56-78-27 Date: June 23, 1978
Diameter: 38.1 mm
Density: 1.835 g/cm³
 $C_L = 2.13$ mm/ μ s $C_S = 0.49$ mm/ μ s

IMPACTOR

PMMA, 4.00 mm thick, backed with low-density polyurethane foam,
mounted on 51-mm-diam aluminum alloy projectile
Impact velocity: 0.19 mm/ μ s

TRANSDUCER

Two-terminal, 50- Ω Manganin gage
Locations from impact surface: 2.05 mm, 5.02 mm, and 7.99 mm
Heat treatment: Annealed
Encapsulation: None
Calibration: J. W. Hopson and J. W. Taylor calibration formula
for Manganin gages
 $\sigma = a_1 x + b_1 x^2 + c_1 x^3$ for $x < 0.1$,
 $\sigma = a_2 + b_2 x + c_2 x^2$ for $x > 0.1$,
where $x = \Delta R/R$.
 $a_1 = 521.32$ $b_1 = -1614.86$ $c_1 = 7648.72$
 $a_2 = 6.5950$ $b_2 = 370.37$ $c_2 = 0.00$
Time: Relative

NOTES

The first disk in the layered target was 2.05-mm-thick PMMA. The other disks were propellant.

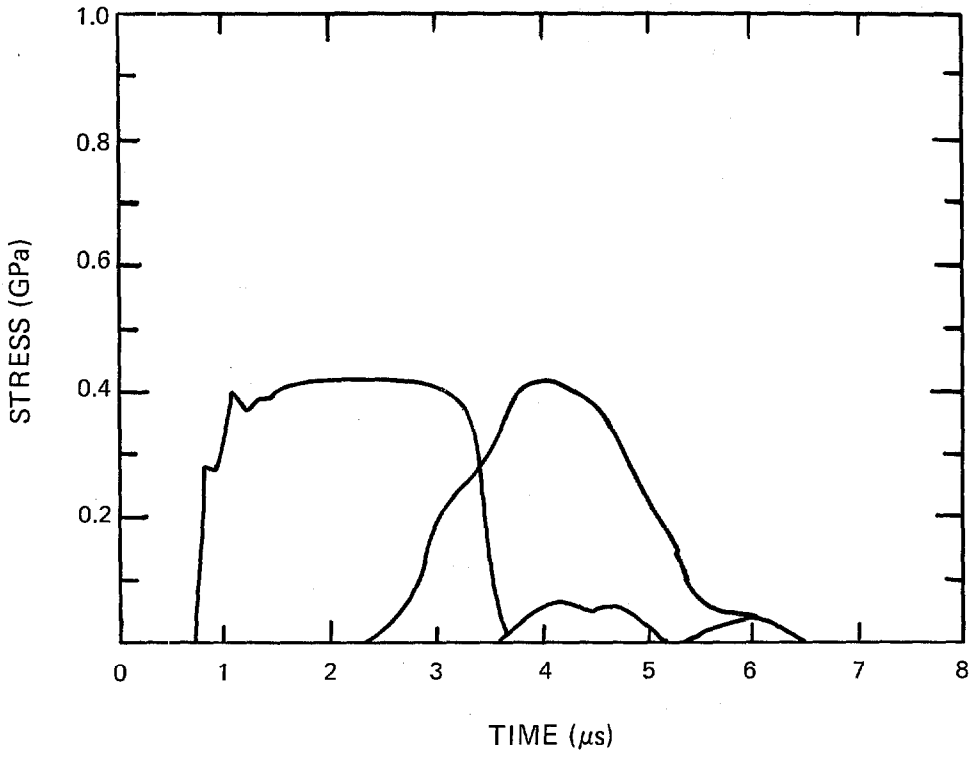

TARGET

Material: VWC-2 Class VII propellant
Experiment type: Embedded Manganin gage
Experimenter: Bart Olinger
Shot no.: 56-78-34 Date: June 28, 1978
Diameter: 38.1 mm
Density: 1.835 g/cm³
 $C_L = 2.13$ mm/ μ s $C_S = 0.49$ mm/ μ s

IMPACTOR

PMMA, 4.00 mm thick, backed with low-density polyurethane foam,
mounted on 51-mm-diam aluminum alloy projectile
Impact velocity: 0.42 mm/ μ s

TRANSDUCER

Two-terminal, 50- Ω Manganin gage
Locations from impact surface: 2.06 mm, 5.04 mm, and 8.02 mm
Heat treatment: Annealed
Encapsulation: None
Calibration: J. W. Hopson and J. W. Taylor calibration formula
for Manganin gages
 $\sigma = a_1 x + b_1 x^2 + c_1 x^3$ for $x < 0.1$,
 $\sigma = a_2 + b_2 x + c_2 x^2$ for $x > 0.1$,
where $x = \Delta R/R$.
 $a_1 = 521.32$ $b_1 = -1614.86$ $c_1 = 7648.72$
 $a_2 = 6.5950$ $b_2 = 370.37$ $c_2 = 0.00$
Time: Relative

NOTES

The first disk in the layered target was 2.06-mm-thick PMMA. The other disks were propellant.

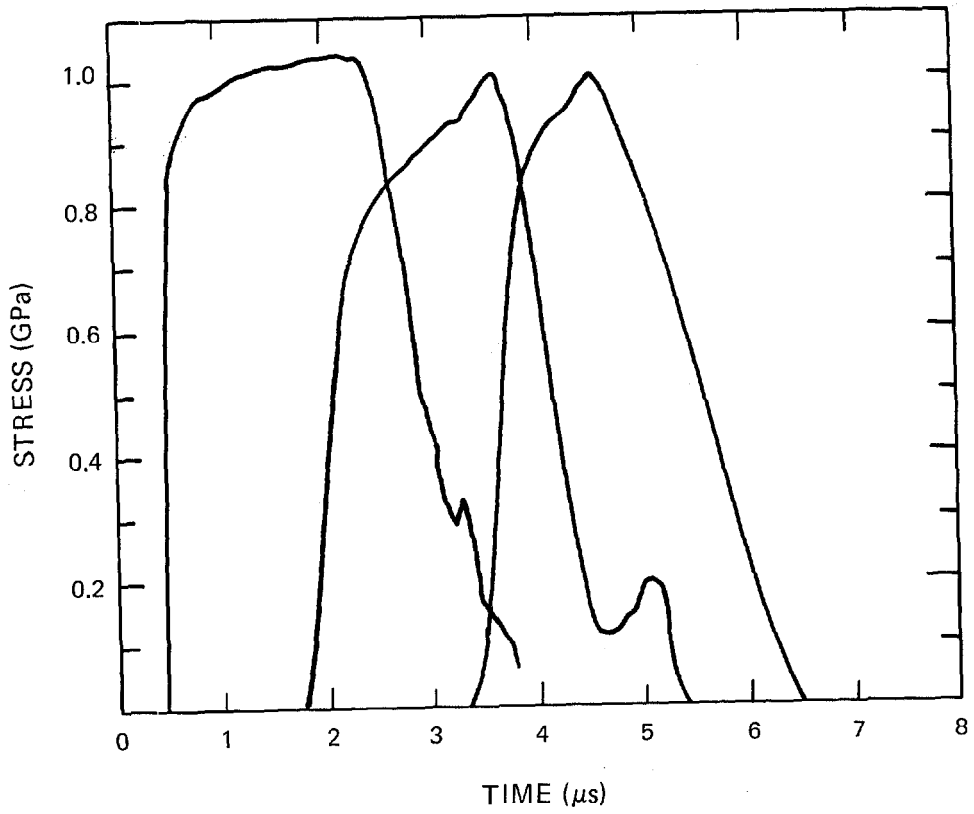

TARGET

Material: VWC-2 Class VII propellant
Experiment type: Embedded Manganin gage
Experimenter: Bart Olinger
Shot no.: 56-78-41 Date: July 24, 1978
Diameter: 38.1 mm
Density: 1.835 g/cm³
 $C_L = 2.13$ mm/ μ s $C_S = 0.49$ mm/ μ s

IMPACTOR

PMMA, 4.10 mm thick, backed with low-density polyurethane foam,
mounted on 51-mm-diam aluminum alloy projectile
Impact velocity: 0.41 mm/ μ s

TRANSDUCER

Two-terminal, 50- Ω Manganin gage
Locations from impact surface: 2.06 mm, 5.06 mm, and 8.06 mm
Heat treatment: Annealed
Encapsulation: None
Calibration: J. W. Hopson and J. W. Taylor calibration formula
for Manganin gages
 $\sigma = a_1 x + b_1 x^2 + c_1 x^3$ for $x < 0.1$,
 $\sigma = a_2 + b_2 x + c_2 x^2$ for $x > 0.1$,
where $x = \Delta R/R$.
 $a_1 = 521.32$ $b_1 = -1614.86$ $c_1 = 7648.72$
 $a_2 = 6.5950$ $b_2 = 370.37$ $c_2 = 0.00$
Time: Relative

NOTES

The first disk in the layered target was 2.06-mm-thick PMMA. The other disks were propellant.

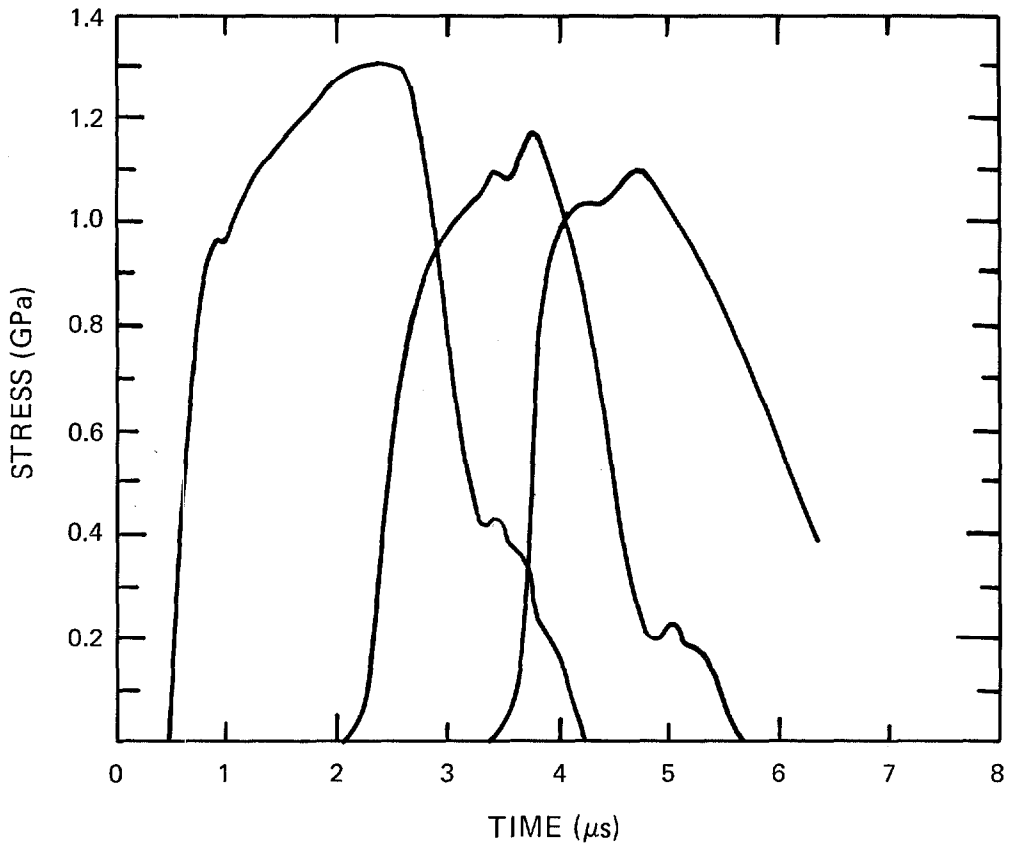

TARGET**Material:** X 0290, 95 wt% TATB and 5 wt% Kel-F**Experiment type:** ASM probe**Experimenter:** W. C. Davis**Reference:** Davis (1976)**Shot no.:** F 3792 **Date:** August 13, 1975**HE SHOT GEOMETRY**P-080 lens/25.4 mm TNT/50.8 mm X 0290/0.075 mm
aluminum//Teflon//**SHOT COMPONENTS**

95 wt% TATB and 5 wt% Kel-F

Density: 1.89 g/cm³

TNT

Density: 1.64 g/cm³ $C_L = 2.48 \text{ mm}/\mu\text{s}$ $C_S = 1.34 \text{ mm}/\mu\text{s}$

Teflon

Density: 2.14 g/cm³ $C_L = 1.23 \text{ mm}/\mu\text{s}$ $C_S = 0.41 \text{ mm}/\mu\text{s}$ **TRANSDUCER**

ASM probe

Coil radius: 18.62 mm **Initial coil spacing:** 6.78 mm

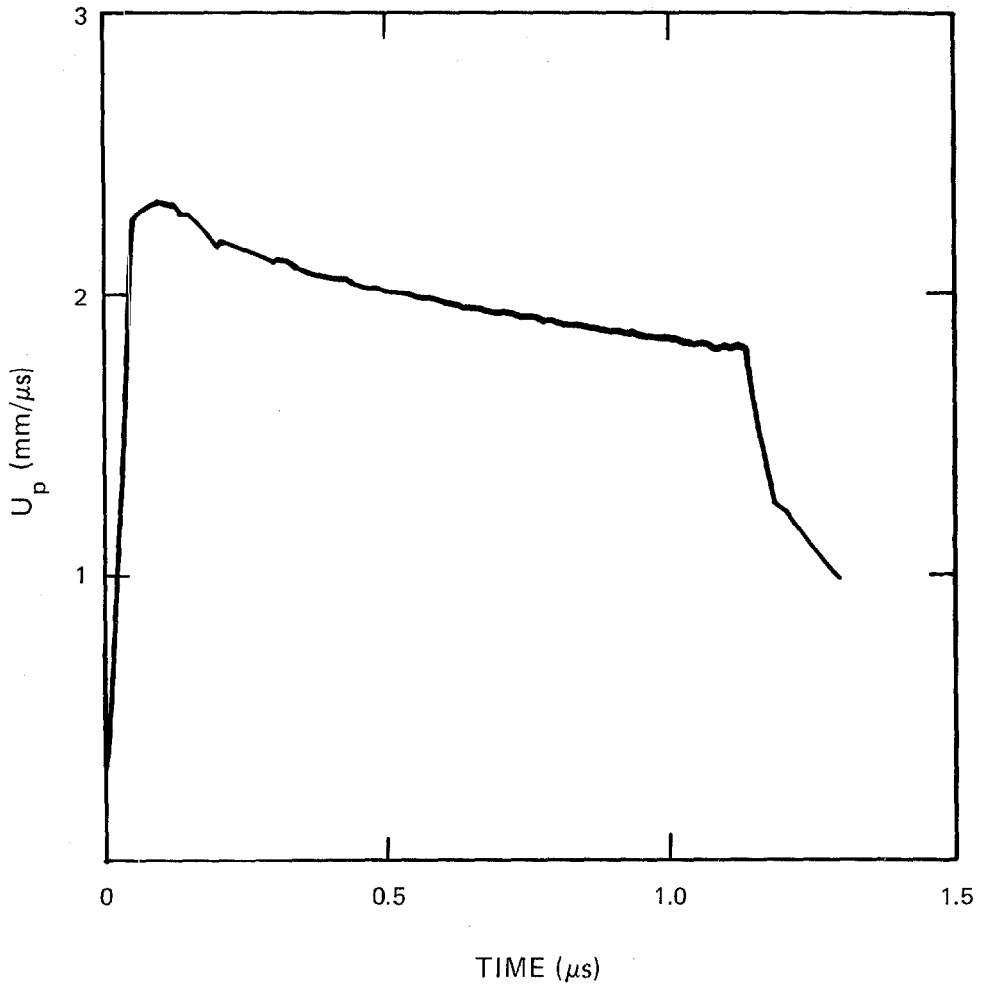

TARGET **Material:** X 0290, 95 wt% TATB and 5 wt% Kel-F
Experiment type: ASM probe
Experimenter: W. C. Davis
Reference: Davis (1976)
Shot no.: F 3795 **Date:** August 15, 1975

HE SHOT GEOMETRY P-080 lens/25.4 mm TNT/101.6 mm X 0290//0.075 mm
aluminum/6.36 mm Teflon//

SHOT COMPONENTS 95 wt% TATB and 5 wt% Kel-F
Density: 1.89 g/cm³
TNT
Density: 1.64 g/cm³
 $C_L = 2.48$ mm/μs $C_S = 1.34$ mm/μs
Teflon
Density: 2.14 g/cm³
 $C_L = 1.23$ mm/μs $C_S = 0.41$ mm/μs

TRANSDUCER ASM probe
Coil radius: 18.62 mm **Initial coil spacing:** 6.79 mm

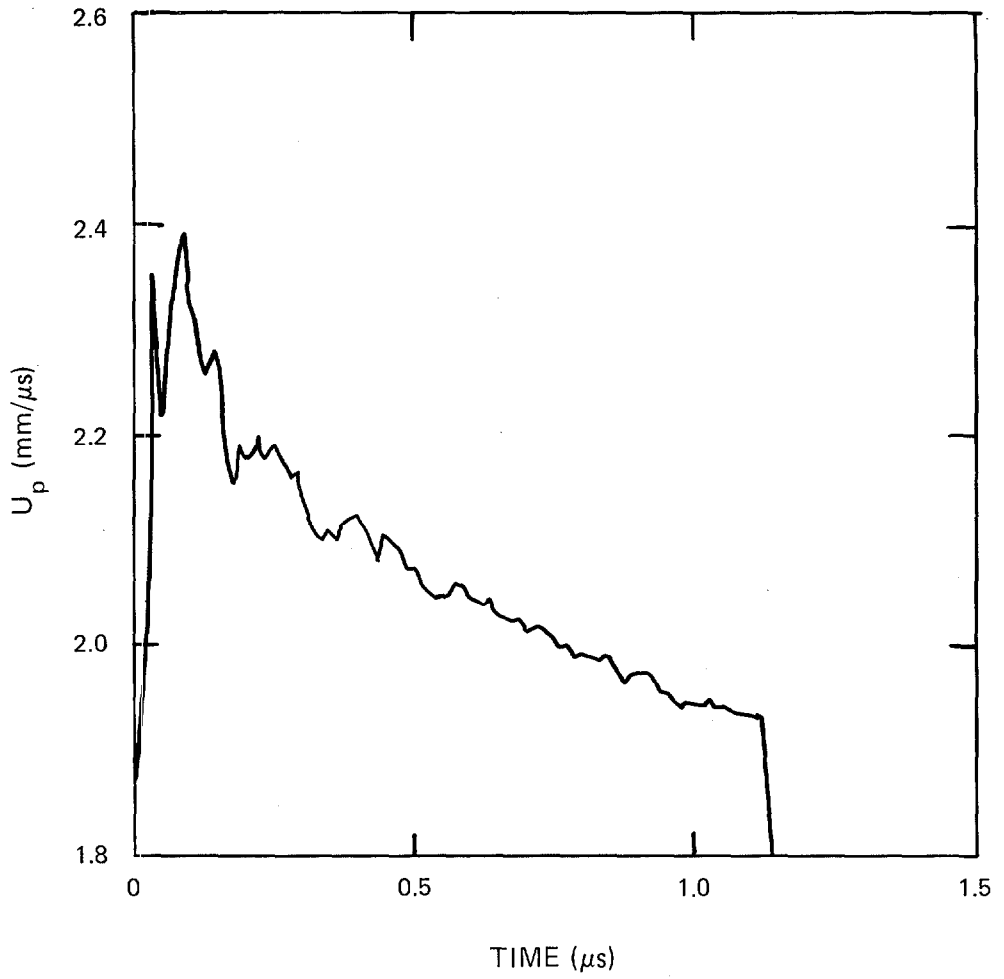

EXPLOSIVES - METAL FREE-RUN SYSTEMS

TARGET **Material:** Comp B - 2024 aluminum free-run system
Experiment type: ASM probe
Experimenters: J. N. Fritz and J. A. Morgan
Reference: Mader (1979)
Shot no.: M 32s1 **Date:** May 11, 1971

HE SHOT GEOMETRY P-081 lens/50.8 mm Comp B/3.167 mm 2024 aluminum//
12.56 mm air/4.95 mm polymethyl methacrylate//

SHOT COMPONENTS Comp B
Density: 1.726 g/cm³
 $C_L = 3.12$ mm/μs $C_S = 1.71$ mm/μs
2024 aluminum
Density: 2.785 g/cm³
 $C_L = 6.36$ mm/μs $C_S = 3.16$ mm/μs

TRANSDUCER ASM probe
Coil radius: 38.17 mm **Initial coil spacing:** 17.51 mm
Time: Relative

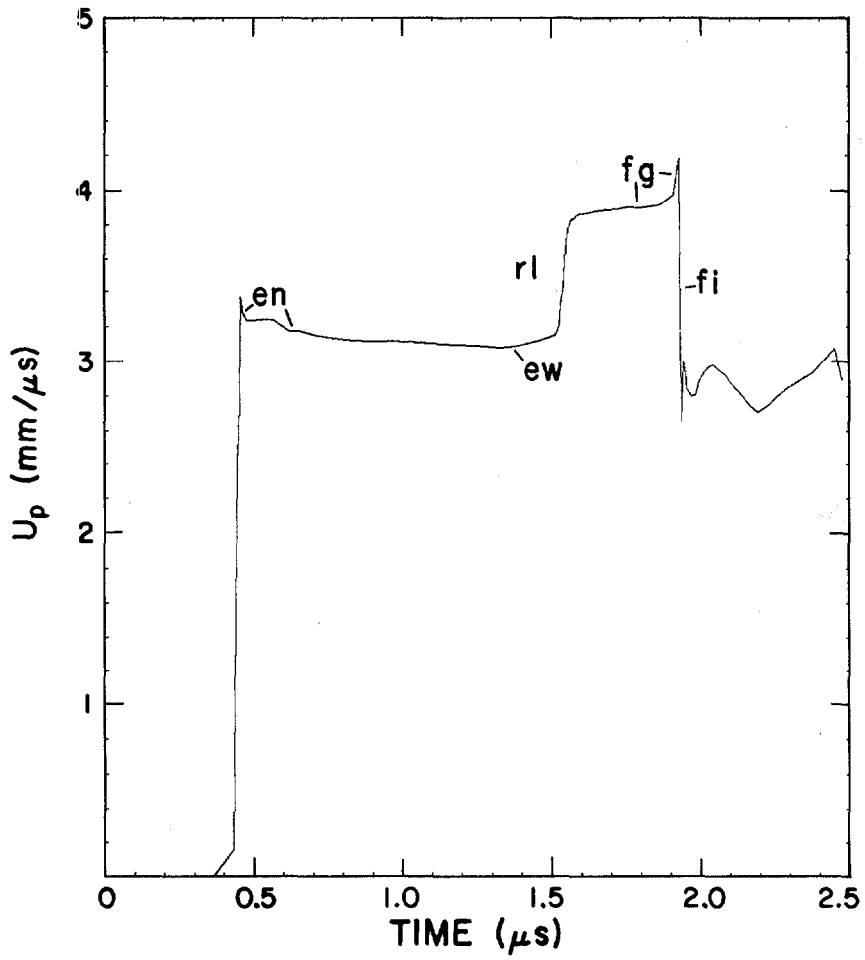

TARGET**Material:** Comp B - 2024 aluminum free-run system**Experiment type:** ASM probe**Experimenters:** J. N. Fritz and J. A. Morgan**Reference:** Mader (1979)**Shot no.:** M 33s1 **Date:** May 13, 1971**HE SHOT GEOMETRY**

P-081 lens/50.8 mm Comp B/6.296 mm 2024 aluminum

//10.13 mm air/4.84 mm polymethyl methacrylate//

SHOT COMPONENTS

Comp B

Density: 1.726 g/cm³ $C_L = 3.12 \text{ mm}/\mu\text{s}$ $C_S = 1.71 \text{ mm}/\mu\text{s}$

2024 aluminum

Density: 2.785 g/cm³ $C_L = 6.36 \text{ mm}/\mu\text{s}$ $C_S = 3.16 \text{ mm}/\mu\text{s}$ **TRANSDUCER**

ASM probe

Coil radius: 38.17 mm **Initial coil spacing:** 14.97 mm**Time:** Relative

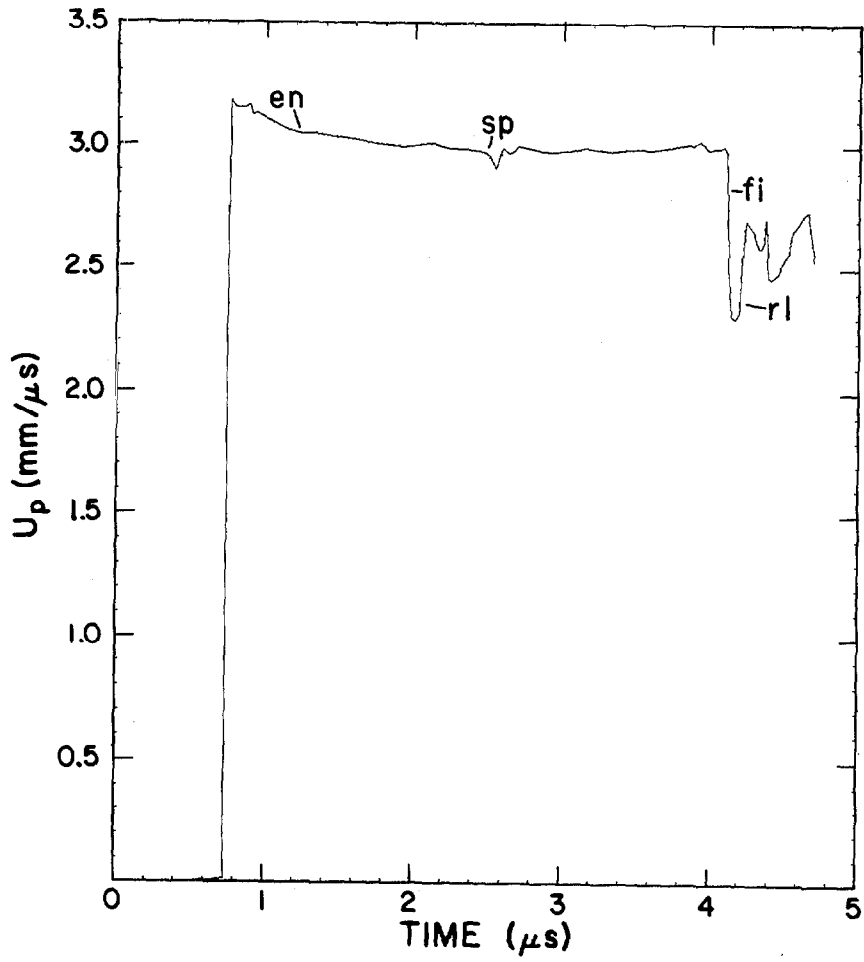

TARGET **Material:** Comp B - 2024 aluminum free-run system
Experiment type: ASM probe
Experimenters: J. N. Fritz and J. A. Morgan
Shot no.: M 34s1 **Date:** May 17, 1971

HE SHOT GEOMETRY P-081 lens/101.6 mm Comp B/6.405 mm 2024 aluminum
//10.02 mm air/5.042 mm polymethyl methacrylate//

SHOT COMPONENTS Comp B
Density: 1.726 g/cm³
 $C_L = 3.12$ mm/μs $C_S = 1.71$ mm/μs
2024 aluminum
Density: 2.785 g/cm³
 $C_L = 6.36$ mm/μs $C_S = 3.16$ mm/μs

TRANSDUCER ASM probe
Coil radius: 38.17 mm **Initial coil spacing:** 15.06 mm
Time: Relative

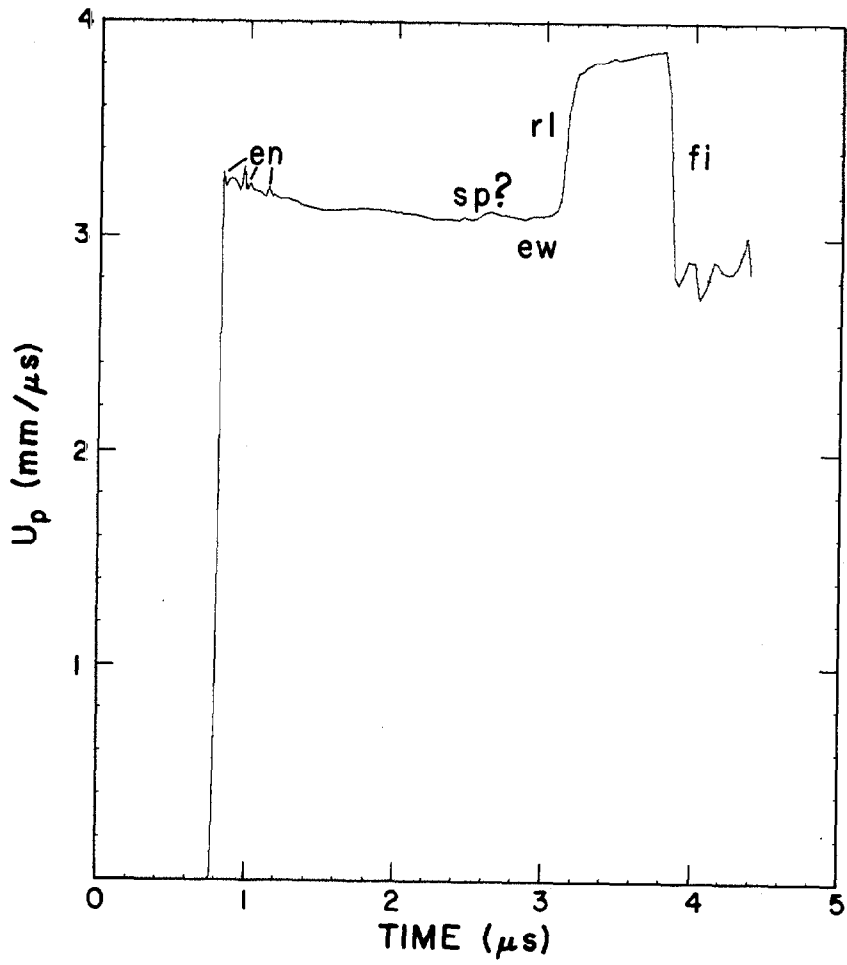

TARGET

Material: Comp B - 2024 aluminum free-run system
Experiment type: ASM probe
Experimenters: J. N. Fritz and J. A. Morgan
Shot no.: M 35s1 **Date:** May 18, 1971

HE SHOT GEOMETRY

P-081 lens/101.6 mm Comp B/3.255 mm 2024 aluminum//
7.543 mm air/5.04 mm polymethyl methacrylate//

SHOT COMPONENTS

Comp B

Density: 1.726 g/cm³

$C_L = 3.12$ mm/ μ s $C_S = 1.71$ mm/ μ s

2024 aluminum

Density: 2.785 g/cm³

$C_L = 6.36$ mm/ μ s $C_S = 3.16$ mm/ μ s

TRANSDUCER

ASM probe

Coil radius: 38.17 mm **Initial coil spacing:** 12.58 mm

Time: Relative

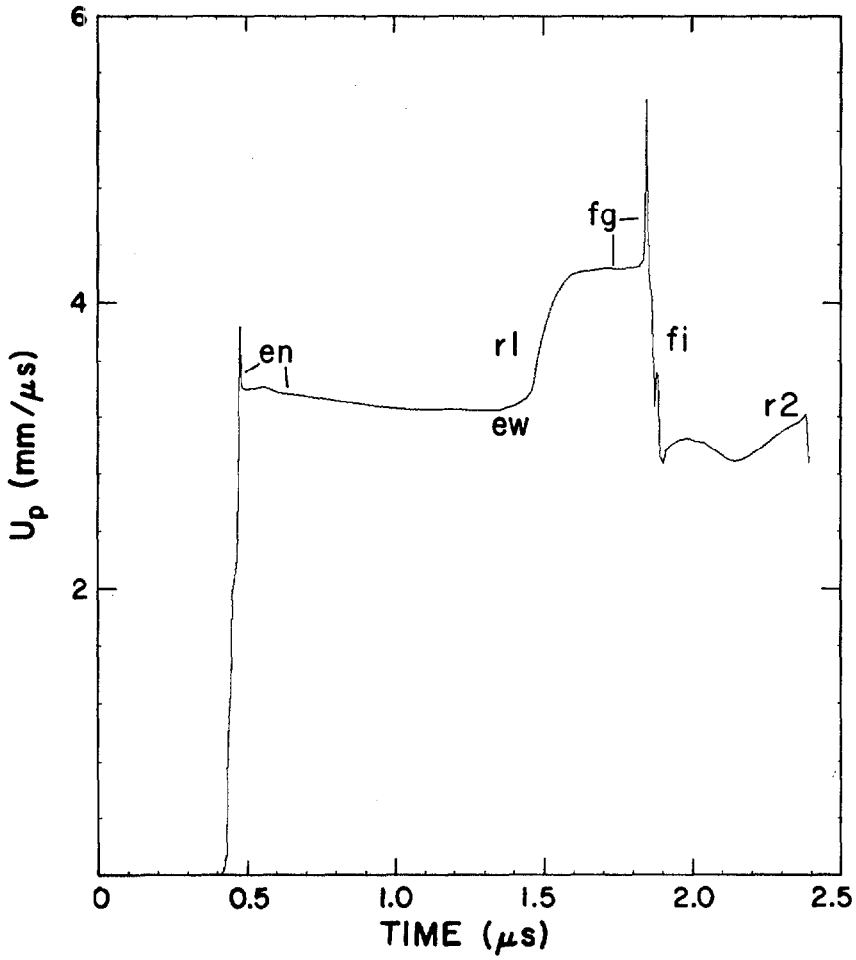

TARGET

Material: Comp B - 2024 aluminum free-run system
Experiment type: ASM probe
Experimenters: J. N. Fritz and J. A. Morgan
Reference: Fritz and Morgan (1973)
Shot no.: M 36s1 **Date:** May 24, 1971

HE SHOT GEOMETRY

P-081 lens/101.6 mm Comp B/6.281 mm 2024 aluminum
//10.02 mm air/5.07 mm polymethyl methacrylate//

SHOT COMPONENTS

Comp B
Density: 1.726 g/cm³
 $C_L = 3.12$ mm/μs $C_S = 1.71$ mm/μs
2024 aluminum
Density: 2.785 g/cm³
 $C_L = 6.36$ mm/μs $C_S = 3.16$ mm/μs

TRANSDUCER

ASM probe
Coil radius: 38.17 mm **Initial coil spacing:** 15.09 mm
Time: Relative

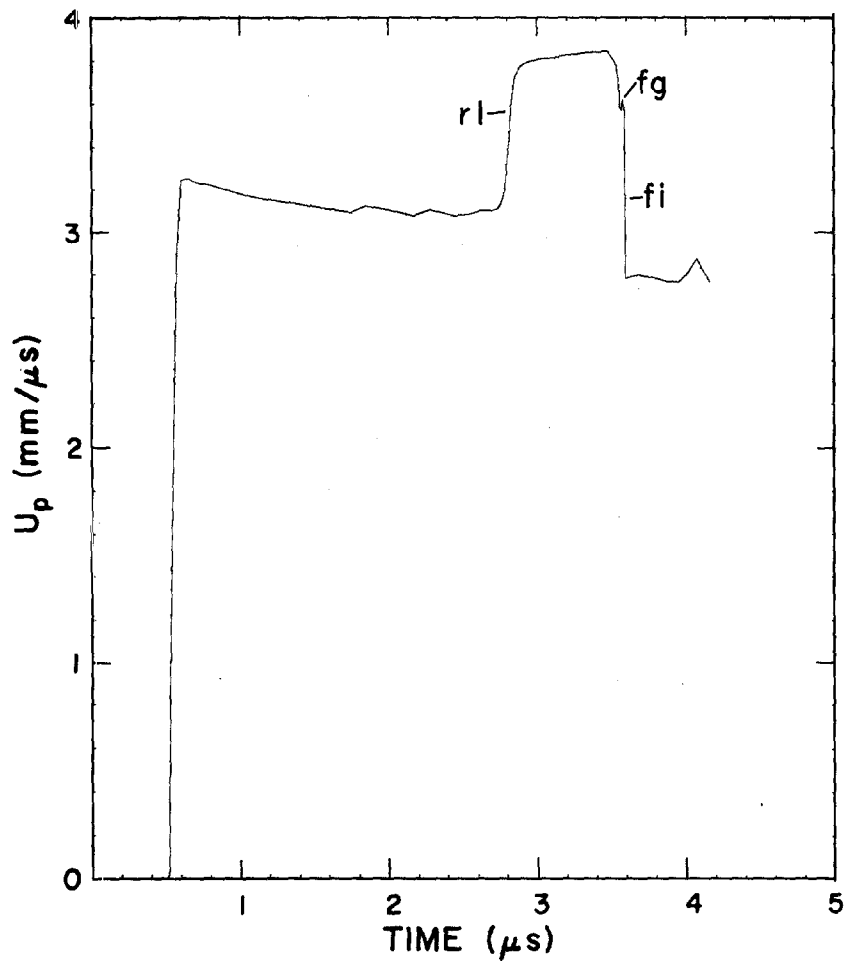

TARGET **Material:** Comp B - 2024 aluminum free-run system
Experiment type: ASM probe
Experimenters: J. N. Fritz and J. A. Morgan
Shot no.: M 39s1 **Date:** August 25, 1971

HE SHOT GEOMETRY P-081 lens/101.6 mm Comp B/1.623 mm 2024 aluminum//
4.00 mm air/3.01 mm polymethyl methacrylate//

SHOT COMPONENTS Comp B
Density: 1.726 g/cm³
 $C_L = 3.12$ mm/μs $C_S = 1.71$ mm/μs
2024 aluminum
Density: 2.785 g/cm³
 $C_L = 6.36$ mm/μs $C_S = 3.16$ mm/μs

TRANSDUCER ASM probe
Coil radius: 9.584 mm **Initial coil spacing:** 7.01 mm
Time: Relative

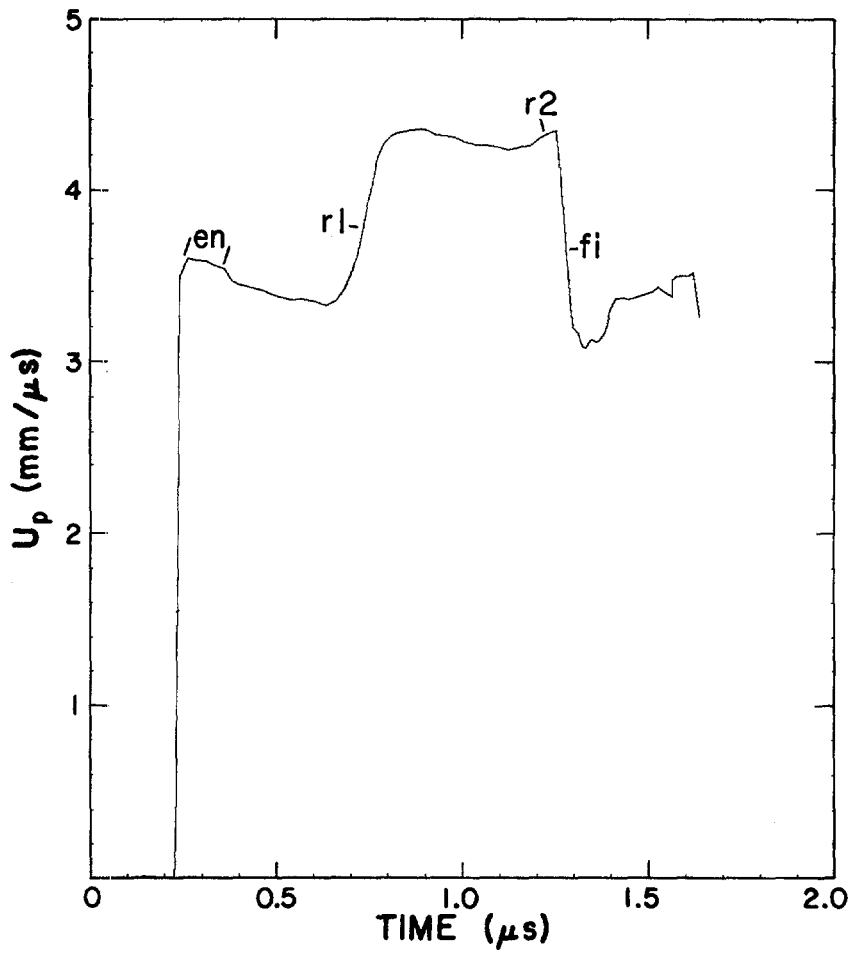

TARGET **Material:** Comp B - 2024 aluminum free-run system
Experiment type: ASM probe
Experimenters: J. N. Fritz and J. A. Morgan
Shot no.: M 40s1 **Date:** August 25, 1971

HE SHOT GEOMETRY P-081 lens/101.6 mm Comp B/0.828 mm 2024 aluminum
 //4.03 mm air/3.00 mm polymethyl methacrylate//

SHOT COMPONENTS Comp B
 Density: 1.726 g/cm³
 C_L = 3.12 mm/μs C_S = 1.71 mm/μs
 2024 aluminum
 Density: 2.785 g/cm³
 C_L = 6.36 mm/μs C_S = 3.16 mm/μs

TRANSDUCER ASM probe
 Coil radius: 9.586 mm **Initial coil spacing:** 7.03 mm
 Time: Relative

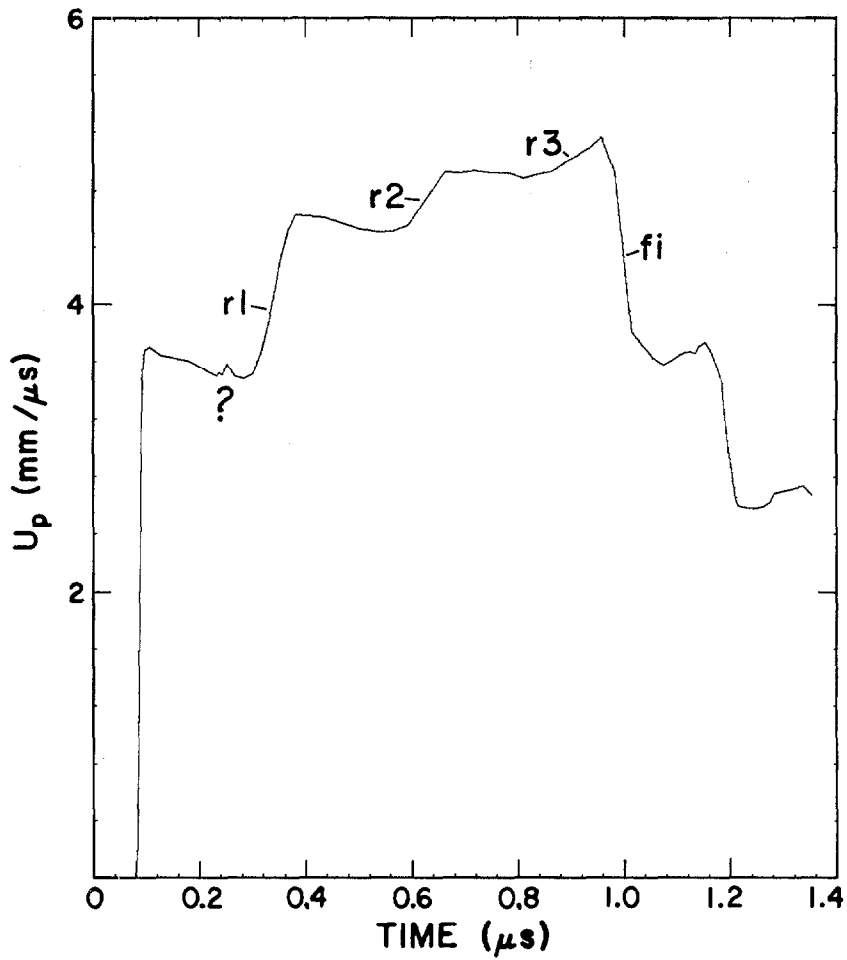

TARGET

Material: Comp B - 2024 aluminum free-run system
Experiment type: ASM probe
Experimenters: J. N. Fritz and J. A. Morgan
Shot no.: M 41s1 **Date:** August 25, 1971

HE SHOT GEOMETRY

P-081 lens/50.8 mm Comp B/0.837 mm 2024 aluminum
//4.03 mm air/3.01 mm polymethyl methacrylate//

SHOT COMPONENTS

Comp B
Density: 1.726 g/cm³
 $C_L = 3.12$ mm/μs $C_s = 1.71$ mm/μs
2024 aluminum
Density: 2.785 g/cm³
 $C_L = 6.36$ mm/μs $C_s = 3.16$ mm/μs

TRANSDUCER

ASM probe
Coil radius: 9.588 mm **Initial coil spacing:** 7.04 mm
Time: Relative

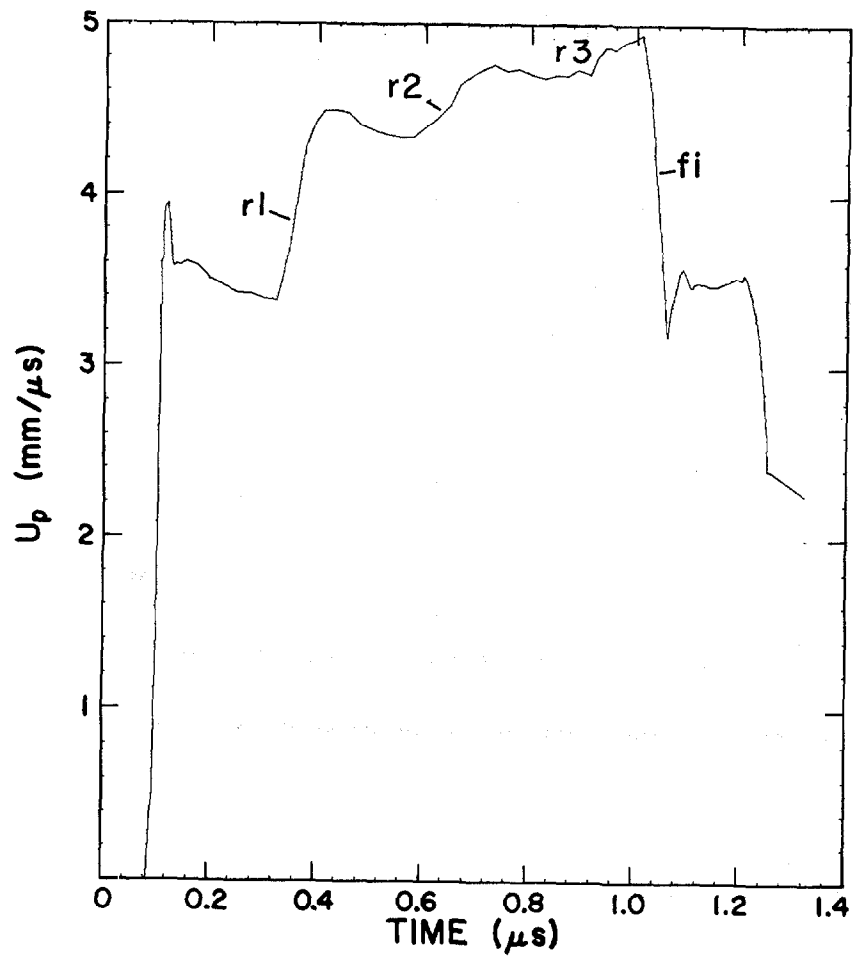

TARGET **Material:** Comp B - 2024 aluminum free-run system
Experiment type: ASM probe
Experimenters: J. N. Fritz and J. A. Morgan
Shot no.: M 42s1 **Date:** August 27, 1971

HE SHOT GEOMETRY P-120 lens /152.4 mm Comp B/6.343 mm 2024 aluminum
//10.02 mm air/5.00 mm polymethyl methacrylate//

SHOT COMPONENTS Comp B
Density: 1.726 g/cm³
C_L = 3.12 mm/μs C_S = 1.71 mm/μs
2024 aluminum
Density: 2.785 g/cm³
C_L = 6.36 mm/μs C_S = 3.16 mm/μs

TRANSDUCER ASM probe
Coil radius: 38.16 mm **Initial coil spacing:** 15.02 mm
Time: Relative

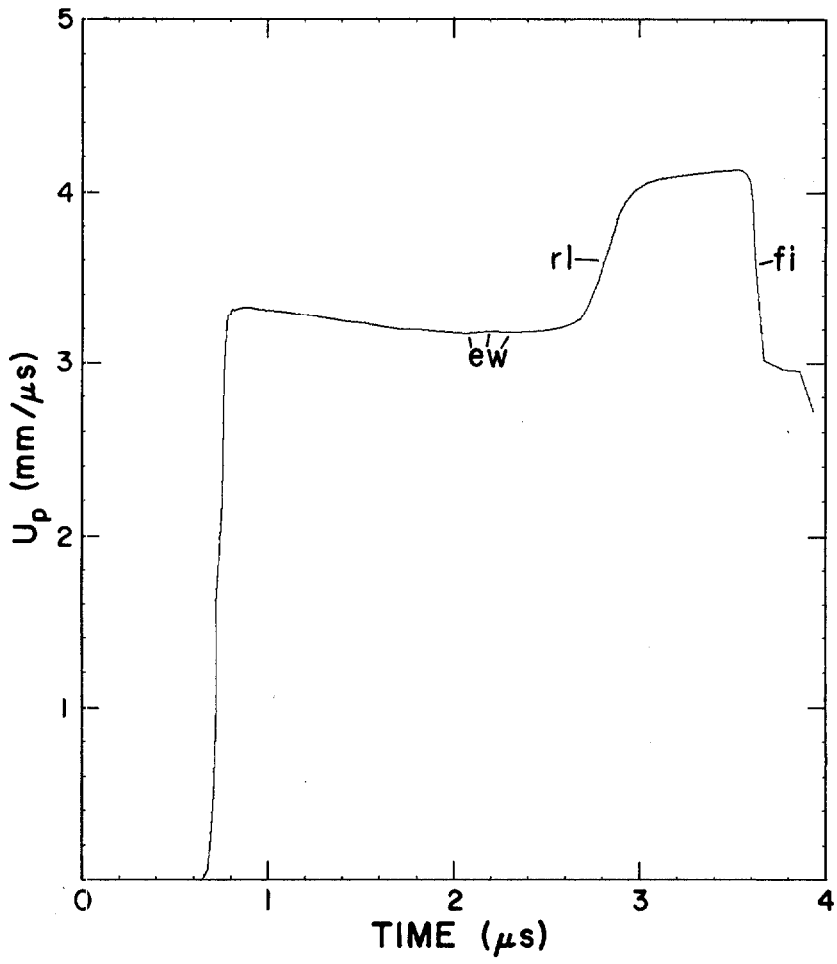

TARGET

Material: Comp B - 2024 aluminum free-run system
Experiment type: ASM probe
Experimenters: J. N. Fritz and J. A. Morgan
Shot no.: M 43s1 **Date:** August 27, 1971

HE SHOT GEOMETRY

P-081 lens/101.6 mm Comp B/1.606 mm 2024 aluminum//
4.02 mm air/3.00 mm polymethyl methacrylate//

SHOT COMPONENTS

Comp B
Density: 1.726 g/cm³
C_L = 3.12 mm/μs C_S = 1.71 mm/μs
2024 aluminum
Density: 2.785 g/cm³
C_L = 6.36 mm/μs C_S = 3.16 mm/μs

TRANSDUCER

ASM probe
Coil radius: 9.60 mm **Initial coil spacing:** 7.02 mm
Time: Relative

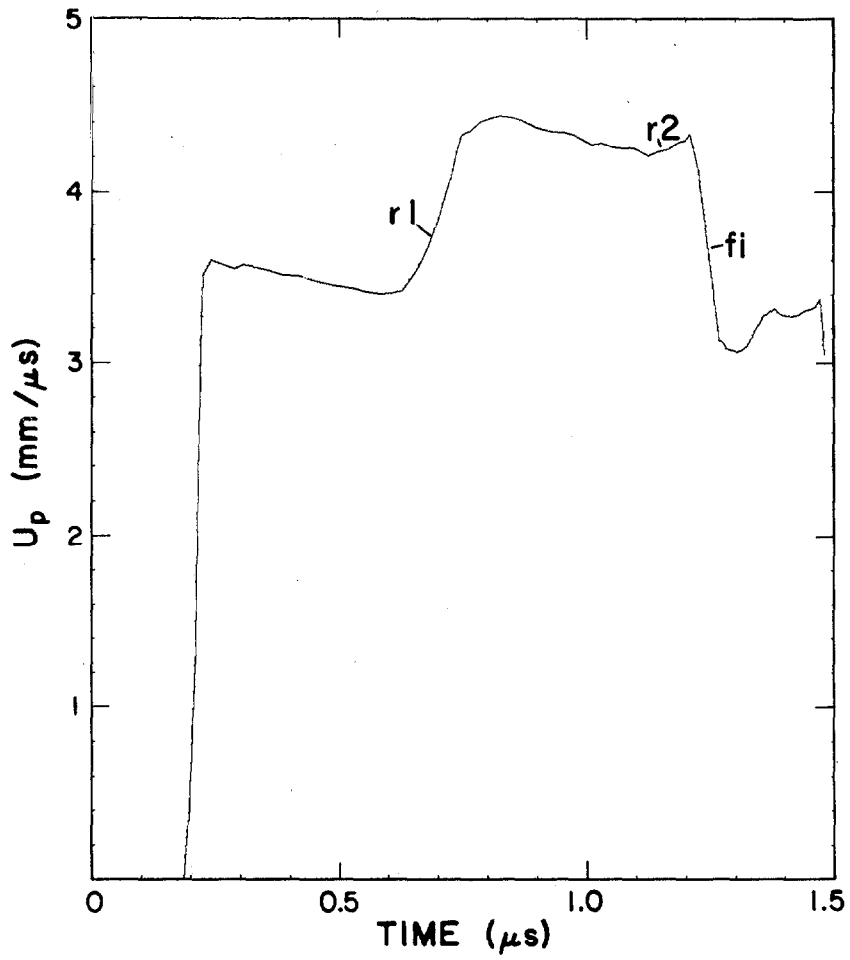

TARGET

Material: Comp B - 2024 aluminum free-run system
Experiment type: ASM probe
Experimenters: J. N. Fritz and J. A. Morgan
Shot no.: M 56s2 **Date:** March 8, 1972

HE SHOT GEOMETRY

P-081 lens/102 mm Comp B/0.493 mm 2024 aluminum
//5.03 mm air/4.97 mm Pyrex glass//

SHOT COMPONENTS

Comp B
Density: 1.726 g/cm³
 $C_L = 3.12$ mm/μs $C_S = 1.71$ mm/μs
2024 aluminum
Density: 2.785 g/cm³
 $C_L = 6.36$ mm/μs $C_S = 3.16$ mm/μs

TRANSDUCER

ASM probe
Coil radius: 28.64 mm **Initial coil spacing:** 10.00 mm
Time: Relative

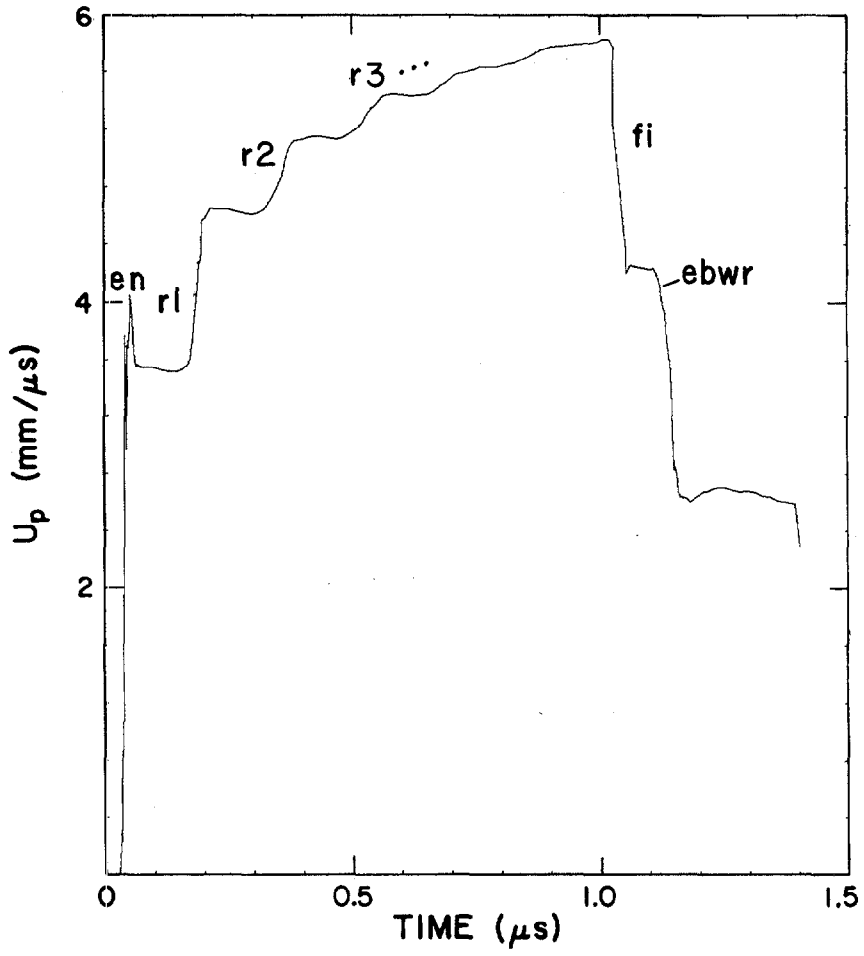

TARGET**Material:** Comp B - 2024 aluminum free-run system**Experiment type:** ASM probe**Experimenters:** J. N. Fritz and J. A. Morgan**Shot no.:** M 57 **Date:** March 12, 1972**HE SHOT GEOMETRY**P-081 lens/102 mm Comp B/0.346 mm 2024 aluminum//
5.13 mm air/5.10 mm Pyrex glass//**SHOT COMPONENTS**

Comp B

Density: 1.726 g/cm³ $C_L = 3.12 \text{ mm}/\mu\text{s}$ $C_S = 1.71 \text{ mm}/\mu\text{s}$

2024 aluminum

Density: 2.785 g/cm³ $C_L = 6.36 \text{ mm}/\mu\text{s}$ $C_S = 3.16 \text{ mm}/\mu\text{s}$ **TRANSDUCER**

ASM probe

Coil radius: 28.64 mm**Initial coil spacing:** 10.23 mm**Time:** Relative

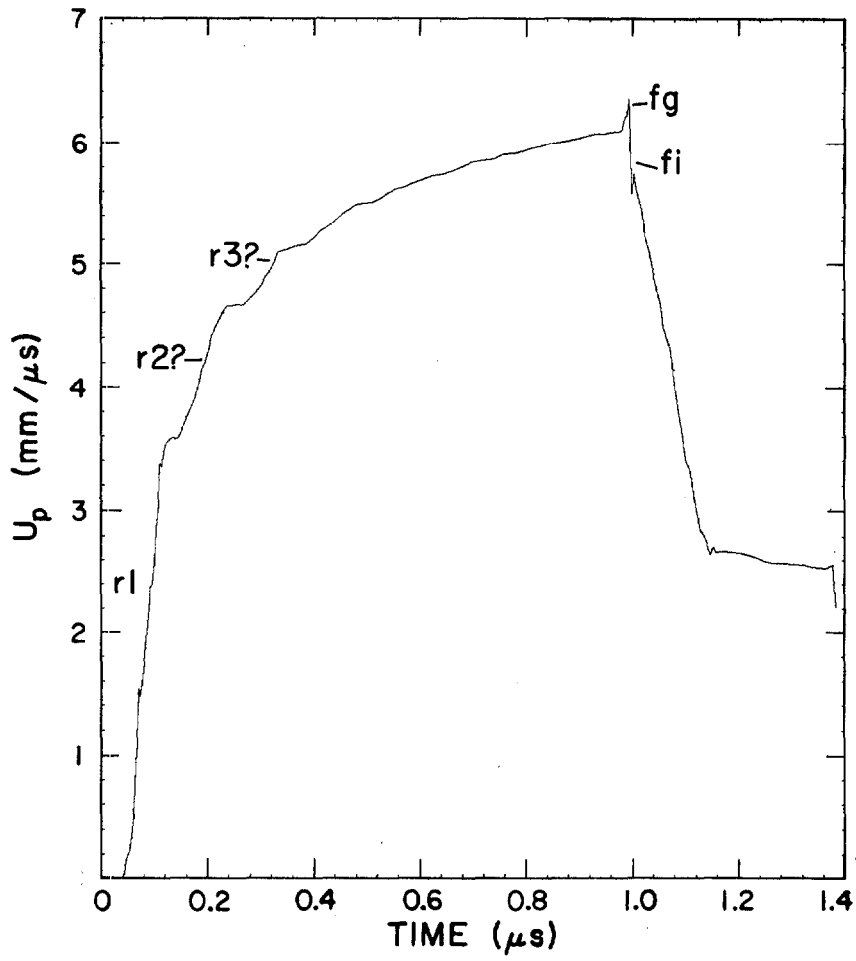

TARGET**Material:** Comp B - aluminum free-run system**Experiment type:** ASM probe**Experimenters:** J. N. Fritz and J. A. Morgan**Shot no.:** M 58 **Date:** March 21, 1972**HE SHOT GEOMETRY**

P-081 lens/102 mm Comp B/0.219 mm aluminum//

5.13 mm air/5.10 mm Pyrex glass//

SHOT COMPONENTS

Comp B

Density: 1.726 g/cm³ $C_L = 3.12 \text{ mm}/\mu\text{s}$ $C_S = 1.71 \text{ mm}/\mu\text{s}$ **TRANSDUCER**

ASM probe

Coil radius: 28.64 mm**Initial coil spacing:** 10.23 mm**Time:** Relative

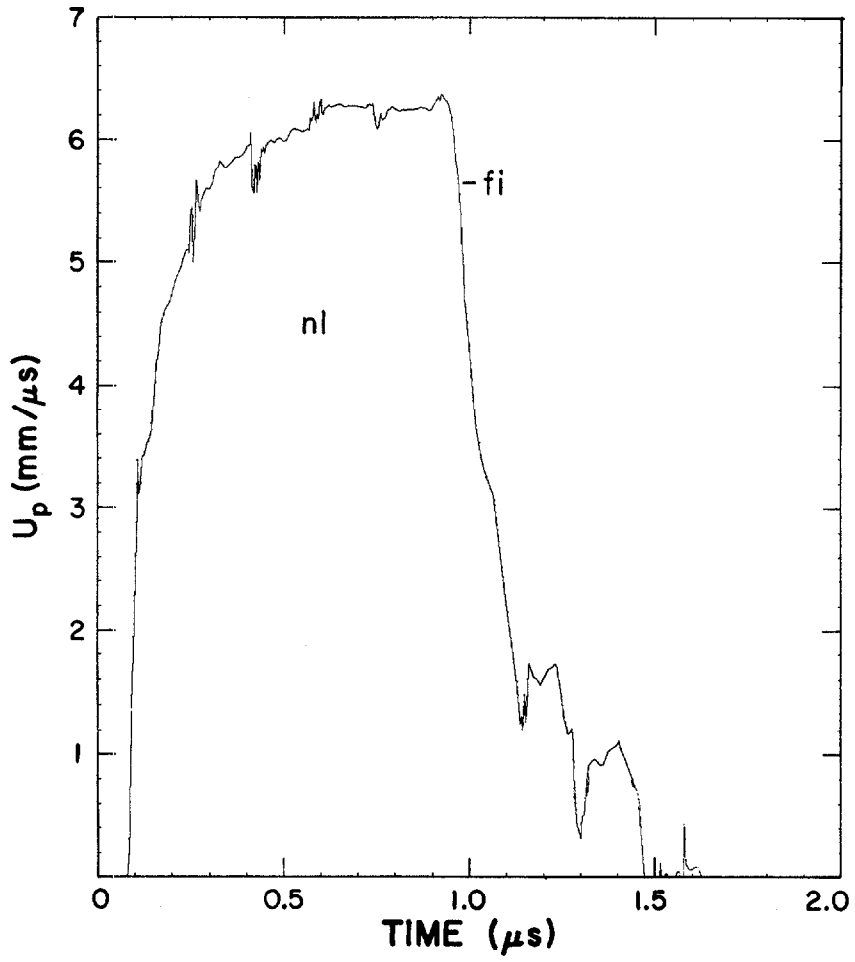

TARGET

Material: Comp B - aluminum free-run system
Experiment type: ASM probe
Experimenters: J. N. Fritz and J. A. Morgan
Shot no.: M 59 **Date:** March 23, 1972

HE SHOT GEOMETRY

P-081 lens/102 mm Comp B/0.221 mm aluminum//
5.13 mm air/5.14 mm Pyrex glass//

SHOT COMPONENTS

Comp B
Density: 1.726 g/cm³
 $C_L = 3.12$ mm/ μ s $C_S = 1.71$ mm/ μ s

TRANSDUCER

ASM probe
Coil radius: 28.64 mm **Initial coil spacing:** 10.27 mm
Time: Relative

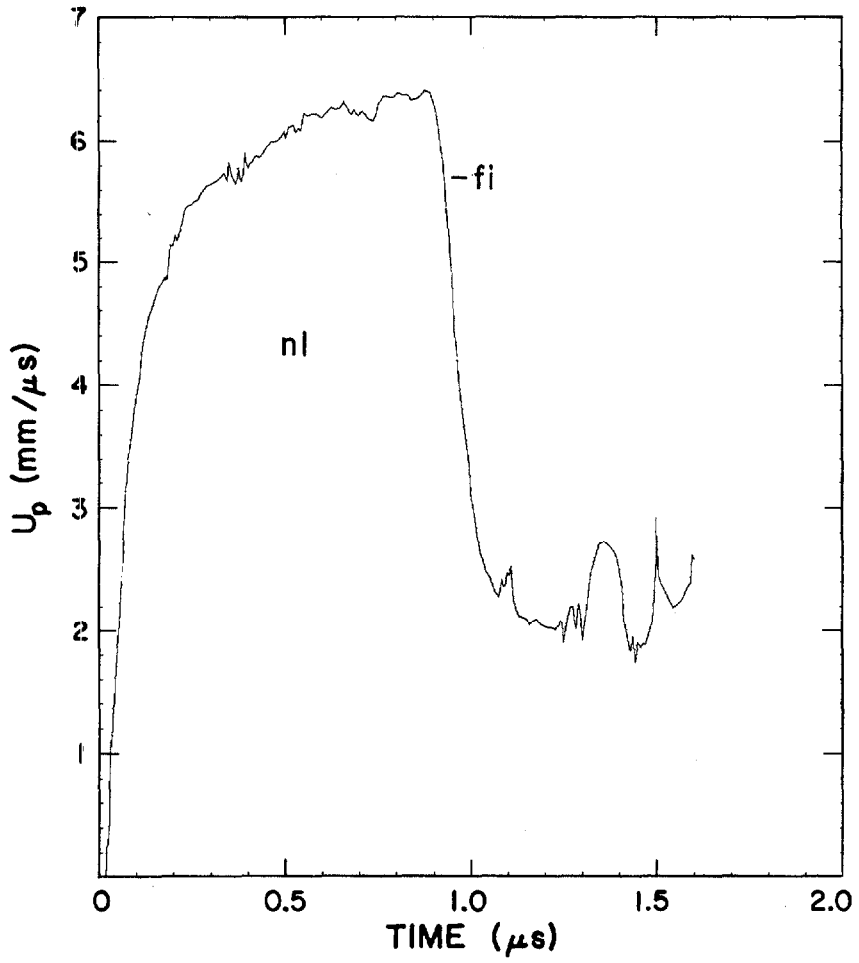

TARGET **Material:** Comp B - aluminum free-run system
Experiment type: ASM probe
Experimenters: J. N. Fritz and J. A. Morgan
Shot no.: M 60 **Date:** April 10, 1972

HE SHOT GEOMETRY P-081 lens/102 mm Comp B/0.222 mm aluminum//
5.01 mm air/5.04 mm Pyrex glass//

SHOT COMPONENTS Comp B
Density: 1.726 g/cm³
C_L = 3.12 mm/μs **C_S** = 1.71 mm/μs

TRANSDUCER ASM probe
Coil radius: 28.64 mm **Initial coil spacing:** 10.05 mm
Time: Relative

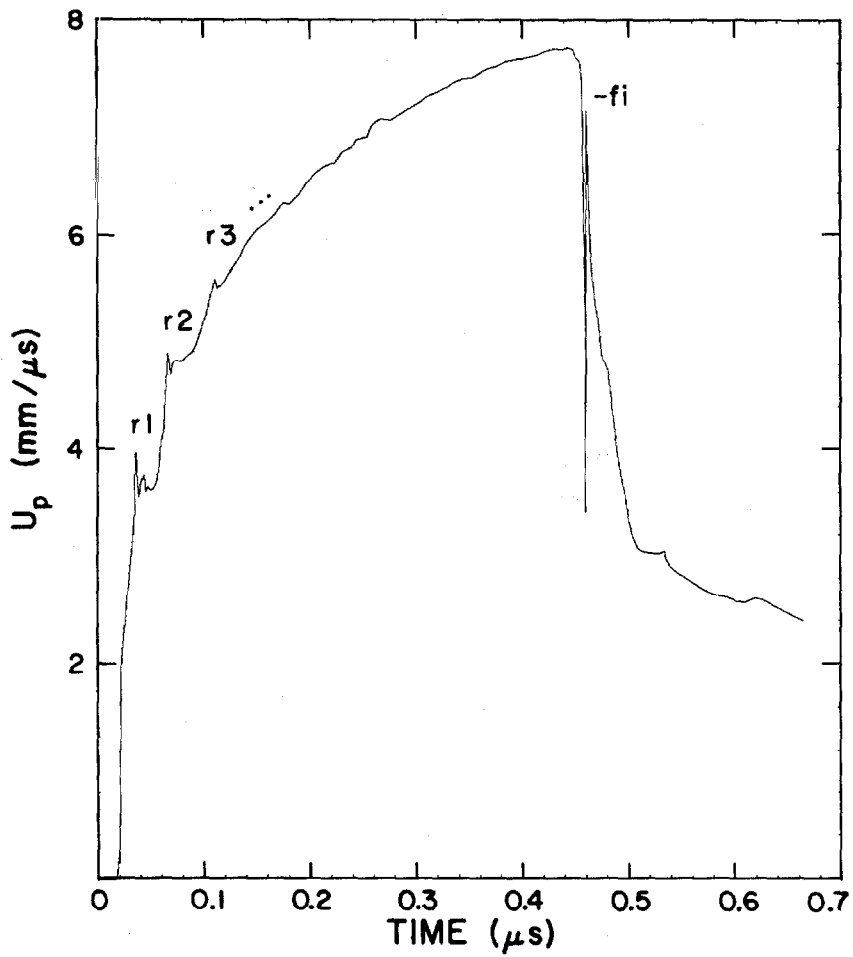

TARGET

Material: Comp B - aluminum free-run system
Experiment type: ASM probe
Experimenters: J. N. Fritz and J. A. Morgan
Shot no.: M 61 **Date:** April 11, 1971

HE SHOT GEOMETRY

P-081 lens/102 mm Comp B/0.074 mm aluminum//
2.49 mm air/5.05 mm Pyrex glass//

SHOT COMPONENTS

Comp B
Density: 1.726 g/cm³
 $C_L = 3.12$ mm/ μ s $C_S = 1.71$ mm/ μ s

TRANSDUCER

ASM probe
Coil radius: 28.64 mm **Initial coil spacing:** 7.54 mm
Time: Relative

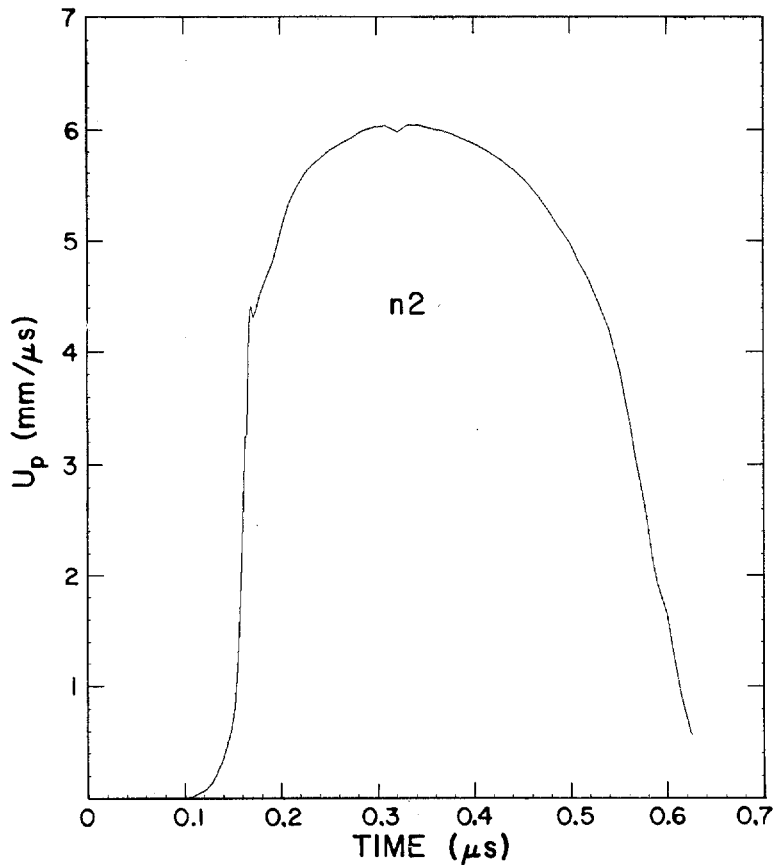

TARGET

Material: Comp B - 6061 aluminum free-run system
Experiment type: ASM probe
Experimenters: J. N. Fritz and J. A. Morgan
Shot no.: M 29s1 **Date:** April 23, 1971

HE SHOT GEOMETRY

P-081 lens/50.8 mm Comp B/3.218 mm 6061 aluminum
//5.014 mm air/5.00 mm polymethyl methacrylate//

SHOT COMPONENTS

Comp B
Density: 1.726 g/cm³
 $C_L = 3.12$ mm/ μ s $C_S = 1.71$ mm/ μ s
6061 aluminum
Density: 2.703 g/cm³
 $C_L = 6.40$ mm/ μ s $C_S = 3.15$ mm/ μ s

TRANSDUCER

ASM probe
Coil radius: 38.25 mm **Initial coil spacing:** 10.01 mm
Time: Relative

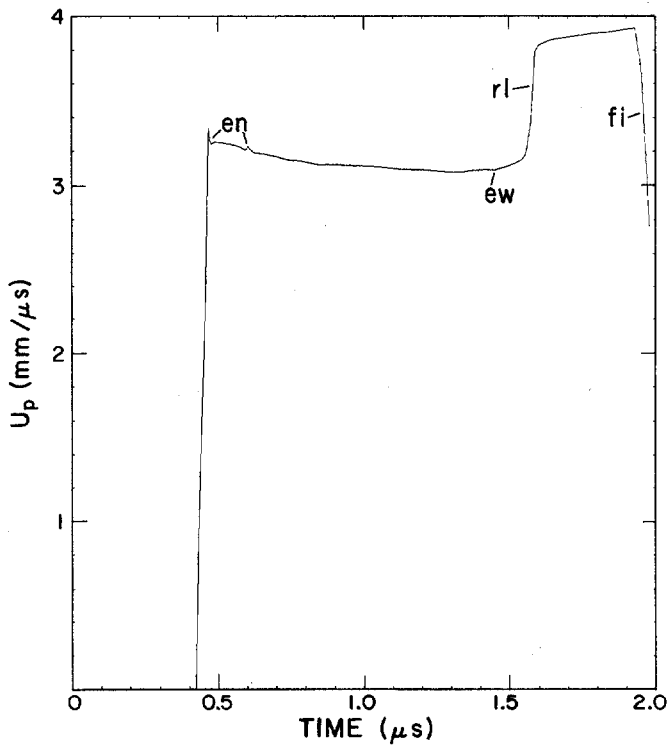

TARGET

Material: Comp B - copper free-run system
Experiment type: ASM probe
Experimenters: J. N. Fritz and J. A. Morgan
Shot no.: M 44s1 Date: August 27, 1971

HE SHOT GEOMETRY

P-081 lens/101.6 mm Comp B/1.613 mm OFHC copper
//4.00 mm air/3.00 mm polymethyl methacrylate//

SHOT COMPONENTS

Comp B
Density: 1.726 g/cm³
C_L = 3.12 mm/μs C_S = 1.71 mm/μs
OFHC copper
Density: 8.93 g/cm³
C_L = 4.76 mm/μs C_S = 2.33 mm/μs

TRANSDUCER

ASM probe
Coil radius: 9.587 mm Initial coil spacing: 7.00 mm
Time: Relative

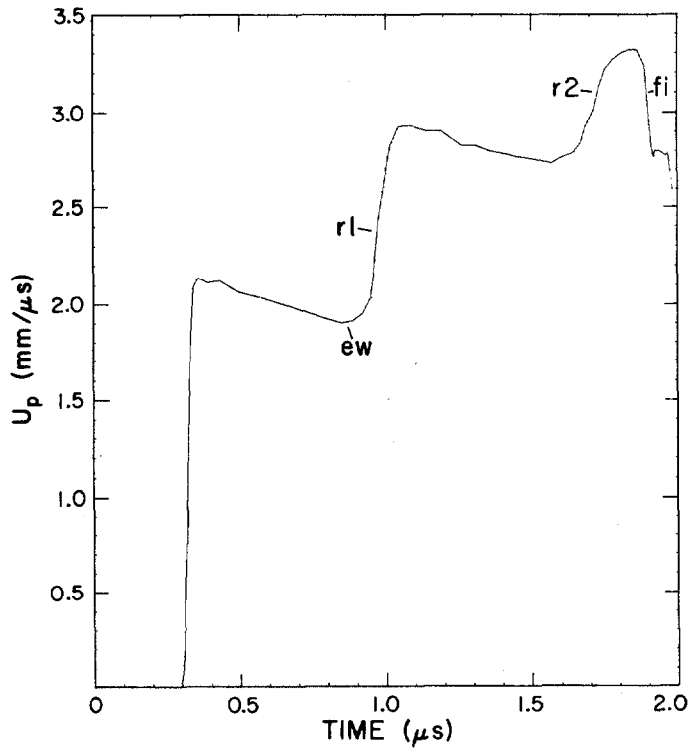

TARGET

Material: Comp B - copper free-run system
Experiment type: ASM probe
Experimenters: J. N. Fritz and J. A. Morgan
Shot no.: M 45s1 Date: August 27, 1971

HE SHOT GEOMETRY

P-081 lens/101.6 mm Comp B/0.838 mm OFHC copper//
4.01 mm air/3.02 mm polymethyl methacrylate//

SHOT COMPONENTS

Comp B
Density: 1.726 g/cm³
C_L = 3.12 mm/μs C_S = 1.71 mm/μs
OFHC copper
Density: 8.93 g/cm³
C_L = 4.76 mm/μs C_S = 2.33 mm/μs

TRANSDUCER

ASM probe
Coil radius: 9.582 mm Initial coil spacing: 7.03 mm
Time: Relative

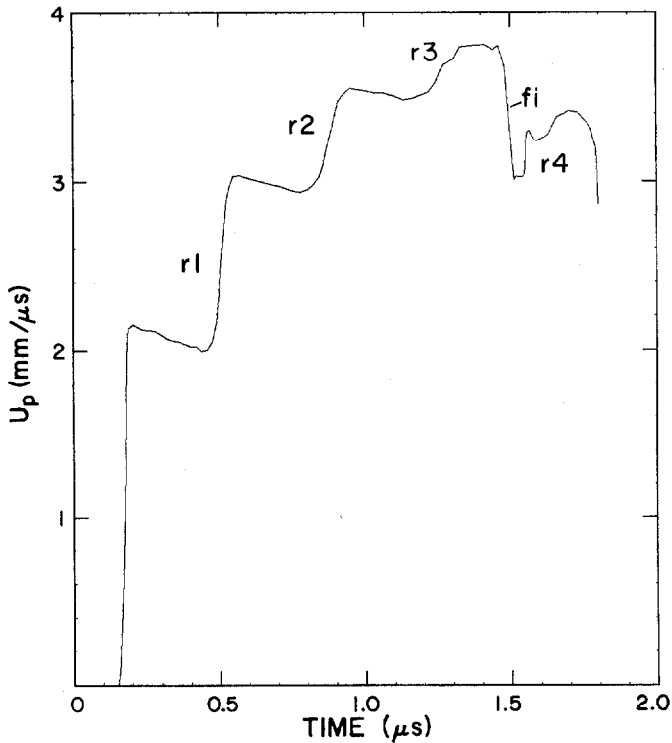

TARGET

Material: Comp B - copper free-run system
Experiment type: ASM probe
Experimenters: J. N. Fritz and J. A. Morgan
Shot no.: M 46s1 **Date:** August 27, 1971

HE SHOT GEOMETRY

P-081 lens/50.8 mm Comp B/1.615 mm OFHC copper
//3.99 mm air/3.01 mm polymethyl methacrylate//

SHOT COMPONENTS

Comp B
Density: 1.726 g/cm³
 $C_L = 3.12$ mm/ μ s $C_S = 1.71$ mm/ μ s
OFHC copper
Density: 8.93 g/cm³
 $C_L = 4.76$ mm/ μ s $C_S = 2.33$ mm/ μ s

TRANSDUCER

ASM probe
Coil radius: 9.573 mm **Initial coil spacing:** 7.00 mm
Time: Relative

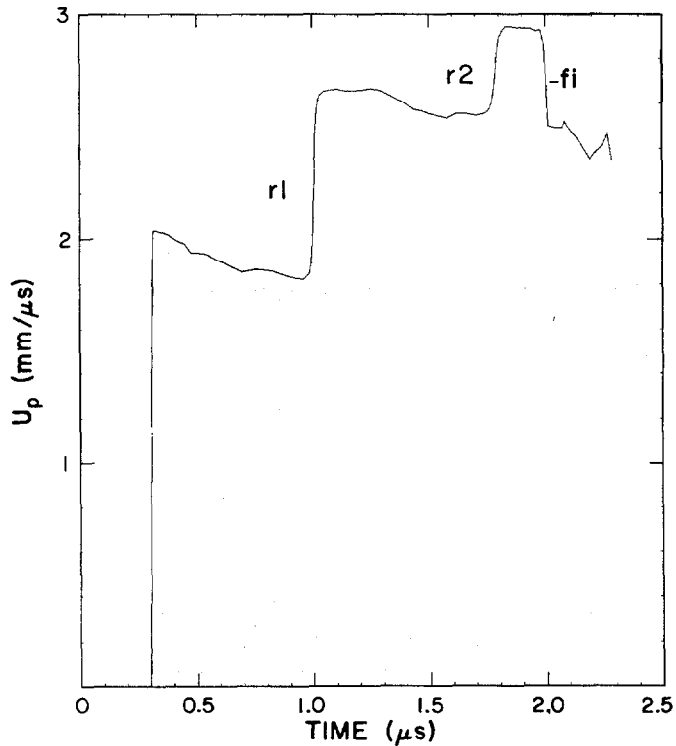

TARGET

Material: Comp B - copper free-run system
Experiment type: ASM probe
Experimenters: J. N. Fritz and J. A. Morgan
Shot no.: M 47s1 Date: August 27, 1971

HE SHOT GEOMETRY P-081 lens/50.8 mm Comp B/0.832 mm OFHC copper//
4.01 mm air/2.98 mm polymethyl methacrylate//

SHOT COMPONENTS

Comp B
Density: 1.726 g/cm³
C_L = 3.12 mm/μs C_S = 1.71 mm/μs
OFHC copper
Density: 8.93 g/cm³
C_L = 4.76 mm/μs C_S = 2.33 mm/μs

TRANSDUCER

ASM probe
Coil radius: 9.59 mm Initial coil spacing: 6.99 mm
Time: Relative

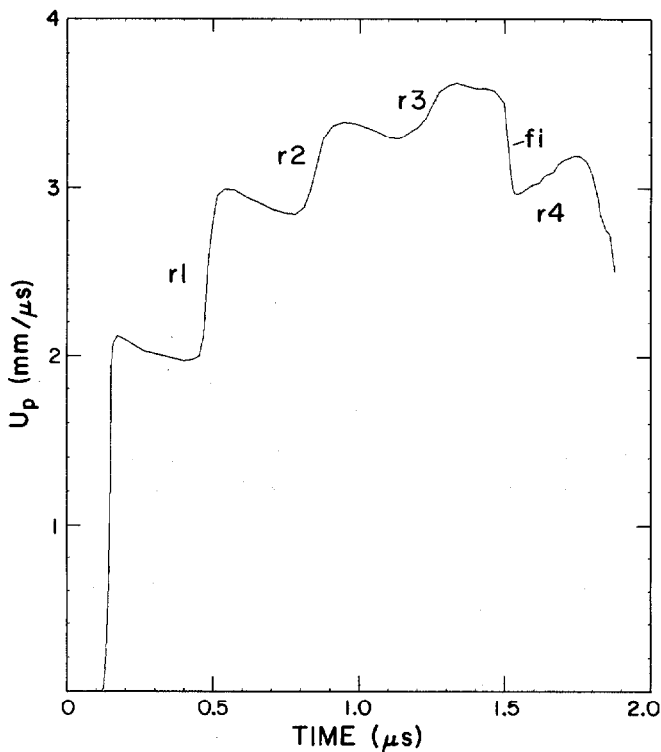

TARGET

Material: Comp B - copper free-run system
Experiment type: ASM probe
Experimenters: J. N. Fritz and J. A. Morgan
Shot no.: M 80 **Date:** February 15, 1973

HE SHOT GEOMETRY

P-081 lens/103 mm Comp B/5.10 mm OFHC copper
//2.07 mm air/polymethyl methacrylate//

SHOT COMPONENTS

Comp B
Density: 1.726 g/cm³
 $C_L = 3.12$ mm/ μ s $C_s = 1.71$ mm/ μ s
OFHC copper
Density: 8.93 g/cm³
 $C_L = 4.76$ mm/ μ s $C_s = 2.33$ mm/ μ s

TRANSDUCER

ASM probe
Coil radius: 4.79 mm **Initial coil spacing:** 2.52 mm
Time: Relative

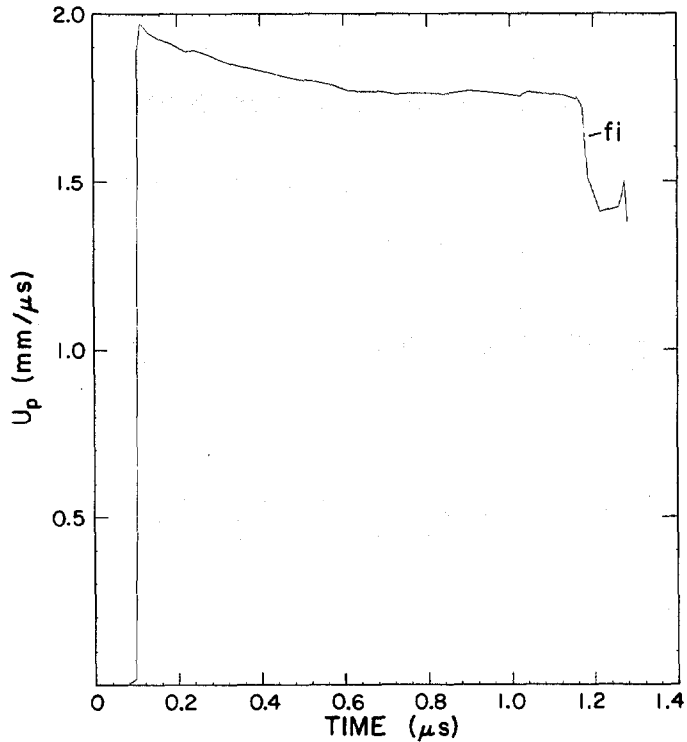

TARGET

Material: PBX 9404 - 2024 aluminum free-run system
Experiment type: ASM probe
Experimenters: J. N. Fritz and J. A. Morgan
Shot no.: M 94 **Date:** January 30, 1975

HE SHOT GEOMETRY

P-120 lens/152 mm PBX 9404/7.2 mm air/0.25 mm polyethylene/3.21 mm 2024 aluminum//28.5 mm air/3.5 mm foam//

SHOT COMPONENTS

PBX 9404
Density: 1.830 g/cm³
 $C_L = 2.90$ mm/ μ s $C_S = 1.57$ mm/ μ s
2024 aluminum
Density: 2.785 g/cm³
 $C_L = 6.36$ mm/ μ s $C_S = 3.16$ mm/ μ s

TRANSDUCER

ASM probe
Coil radius: 35.10 mm **Initial coil spacing:** 32.00 mm
Time: Relative

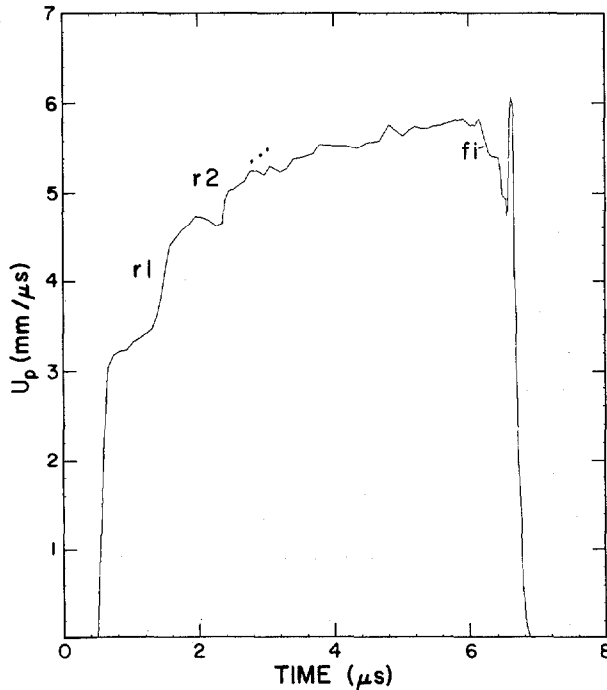

TARGET

Material: PBX 9404 - 2024 aluminum free-run system
Experiment type: ASM probe
Experimenters: J. N. Fritz and J. A. Morgan
Shot no.: M 95 **Date:** March 17, 1975

HE SHOT GEOMETRY

P-120 lens/152 mm PBX 9404/3.2 mm air/ 0.33 mm polyethylene/3.21 mm 2024 aluminum//28.5 mm air/plastic//

SHOT COMPONENTS

PBX 9404
Density: 1.830 g/cm³
 $C_L = 2.90$ mm/ μ s $C_S = 1.57$ mm/ μ s
2024 aluminum
Density: 2.785 g/cm³
 $C_L = 6.36$ mm/ μ s $C_S = 3.16$ mm/ μ s

TRANSDUCER

ASM probe
Coil radius: 35.7 mm
Time: Relative

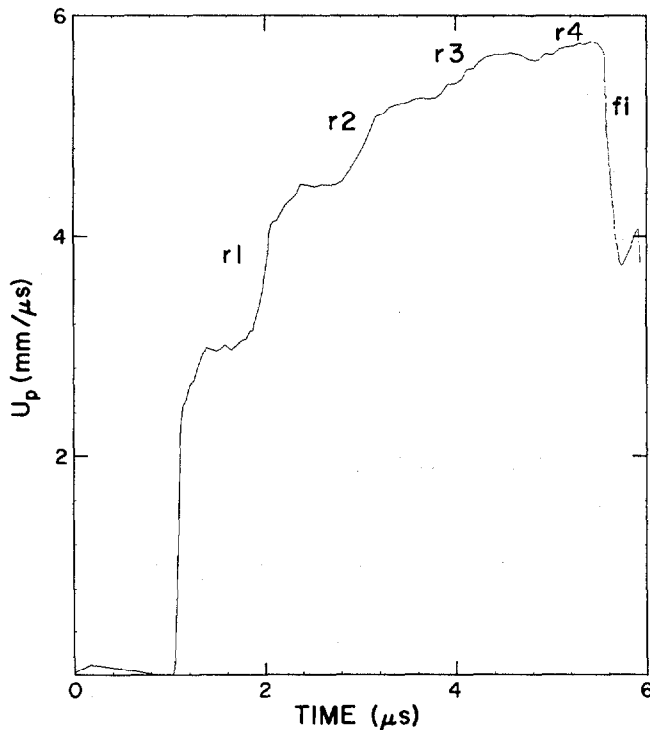

TARGET

Material: PBX 9404 - 2024 aluminum free-run system
Experiment type: ASM probe
Experimenters: J. N. Fritz and J. A. Morgan
Shot no.: M 96 **Date:** November 20, 1975

HE SHOT GEOMETRY

P-120 lens/152 mm PBX 9404/3.1 mm air/7.00 mm 2024 aluminum//27.9 mm air/plastic//

SHOT COMPONENTS

PBX 9404
Density: 1.830 g/cm³
 $C_L = 2.90$ mm/ μ s $C_S = 1.57$ mm/ μ s
2024 aluminum
Density: 2.785 g/cm³
 $C_L = 6.36$ mm/ μ s $C_S = 3.16$ mm/ μ s

TRANSDUCER

ASM probe
Coil radius: 35.1 mm **Initial coil spacing:** 31.76 mm
Time: Relative

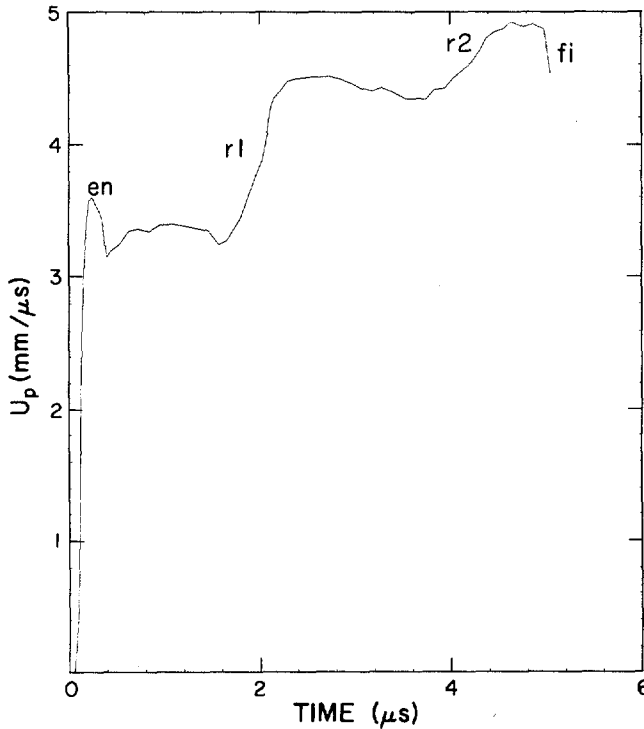

TARGET

Material: PBX 9404 - 2024 aluminum free-run system
Experiment type: ASM probe
Experimenters: J. N. Fritz and J. A. Morgan
Shot no.: M 98 **Date:** January 21, 1976

HE SHOT GEOMETRY

P-120 lens/152 mm PBX 9404/3.2 mm air/6.50 mm 2024 aluminum//27.7 mm air/plastic//

SHOT COMPONENTS

PBX 9404
Density: 1.830 g/cm³
 $C_L = 2.90$ mm/ μ s $C_S = 1.57$ mm/ μ s
2024 aluminum
Density: 2.785 g/cm³
 $C_L = 6.36$ mm/ μ s $C_S = 3.16$ mm/ μ s

TRANSDUCER

ASM probe
Coil radius: 35.1 mm **Initial coil spacing:** 31.86 mm
Time: Relative

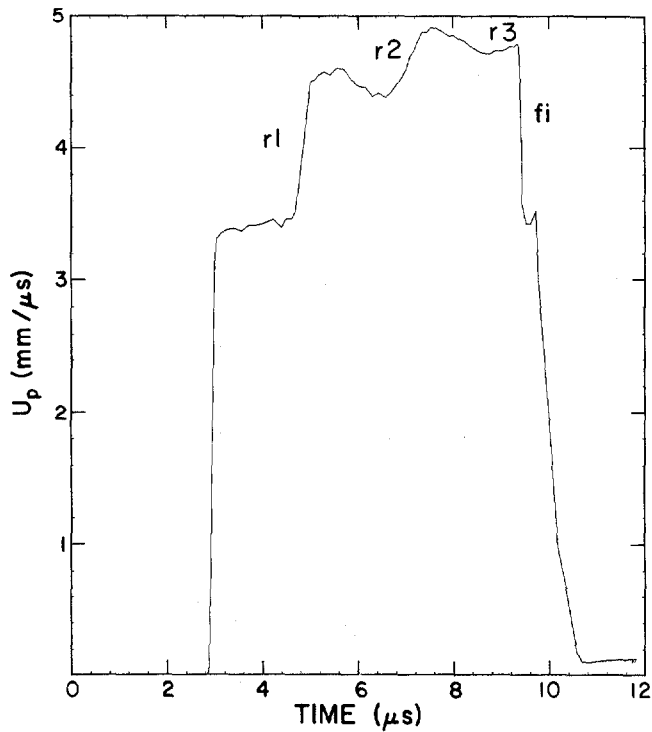

TARGET

Material: PBX 9404 - 2024 aluminum free-run system
Experiment type: ASM probe
Experimenters: J. N. Fritz and J. A. Morgan
Shot no.: M 100 Date: July 8, 1976

HE SHOT GEOMETRY

P-081 lens/203 mm PBX 9404/10.54 mm 2024 aluminum//
28.40 mm air/5.06 mm Pyrex glass//

SHOT COMPONENTS

PBX 9404
Density: 1.830 g/cm³
C_L = 2.90 mm/μs C_S = 1.57 mm/μs
2024 aluminum
Density: 2.785 g/cm³
C_L = 6.36 mm/μs C_S = 3.16 mm/μs

TRANSDUCER

ASM probe
Coil radius: 50.12 mm Initial coil spacing: 33.46 mm
Time: Relative

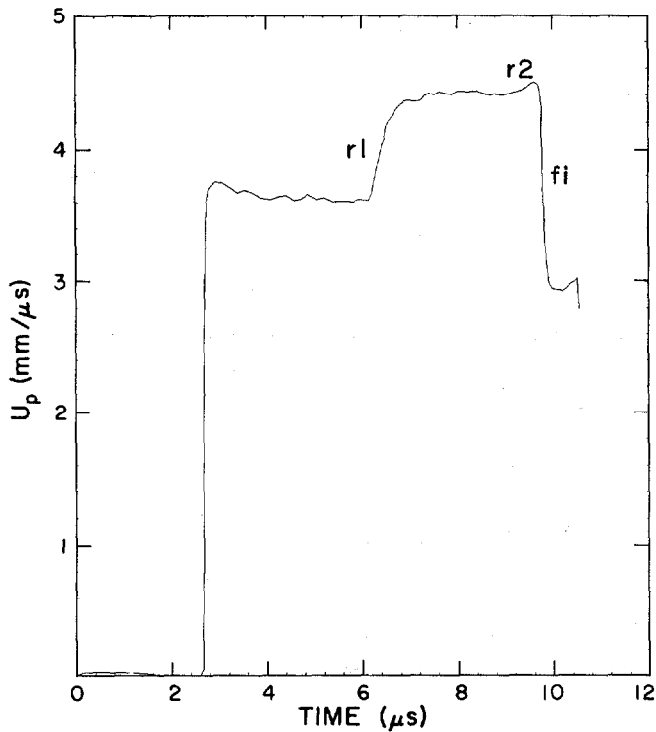

TARGET

Material: PBX 9404 - 2024 aluminum free-run system
Experiment type: ASM probe
Experimenters: J. N. Fritz and J. A. Morgan
Shot no.: M 101 **Date:** July 8, 1976

HE SHOT GEOMETRY

P-081 lens/102 mm PBX 9404/10.57 mm 2024 aluminum//
25.20 mm air/5.04 mm Pyrex glass//

SHOT COMPONENTS

PBX 9404
Density: 1.830 g/cm³
 $C_L = 2.90$ mm/ μ s $C_S = 1.57$ mm/ μ s
2024 aluminum
Density: 2.785 g/cm³
 $C_L = 6.36$ mm/ μ s $C_S = 3.16$ mm/ μ s

TRANSDUCER

ASM probe
Coil radius: 50.12 mm **Initial coil spacing:** 30.24 mm
Time: Relative

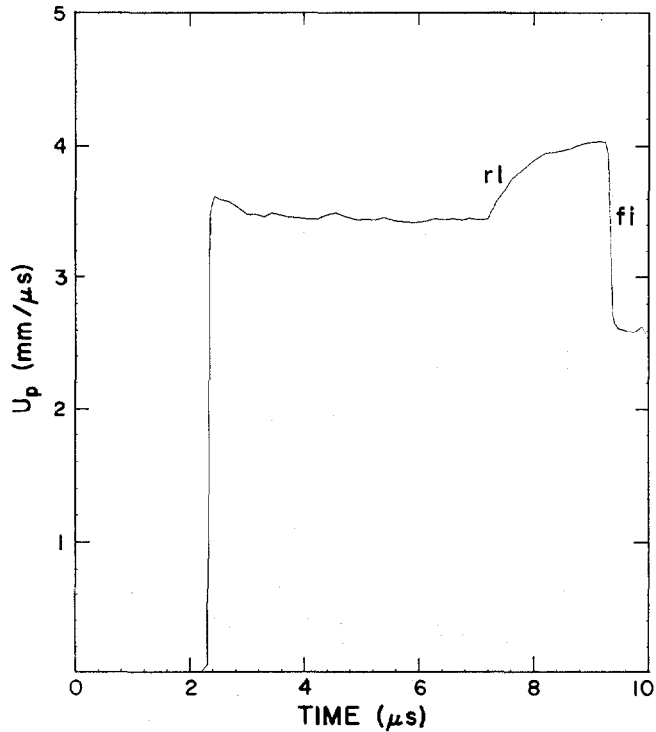

TARGET **Material:** PBX 9404 - 2024 aluminum free-run system
Experiment type: ASM probe
Experimenters: J. N. Fritz and J. A. Morgan
Shot no.: M 102 **Date:** July 12, 1976

HE SHOT GEOMETRY P-081 lens/51 mm PBX 9404/10.58 mm 2024 aluminum//
20.83 mm air/4.98 mm Pyrex glass//

SHOT COMPONENTS PBX 9404
Density: 1.830 g/cm³
 $C_L = 2.90$ mm/ μ s $C_S = 1.57$ mm/ μ s
2024 aluminum
Density: 2.785 g/cm³
 $C_L = 6.36$ mm/ μ s $C_S = 3.16$ mm/ μ s

TRANSDUCER ASM probe
Coil radius: 50.12 mm **Initial coil spacing:** 25.81 mm
Time: Relative

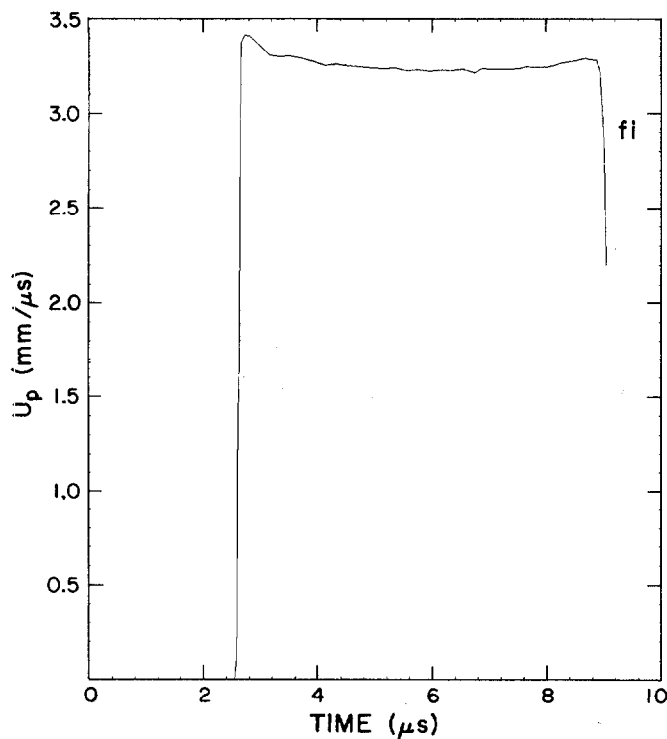

TARGET **Material:** PBX 9404 - 6061 aluminum free-run system
Experiment type: ASM probe
Experimenters: J. N. Fritz and J. A. Morgan
Shot no.: M 87 **Date:** June 14, 1973

HE SHOT GEOMETRY P-040 lens/25 mm PBX 9404/3.18 mm 6061 aluminum
 //25.6 mm air//

SHOT COMPONENTS PBX 9404
 Density: 1.830 g/cm³
 C_L = 2.90 mm/μs C_S = 1.57 mm/μs
 6061 aluminum
 Density: 2.703 g/cm³
 C_L = 6.40 mm/μs C_S = 3.15 mm/μs

TRANSDUCER ASM probe
 Coil radius: 28.64 mm **Initial coil spacing:** 25.6 mm
 Time: Relative

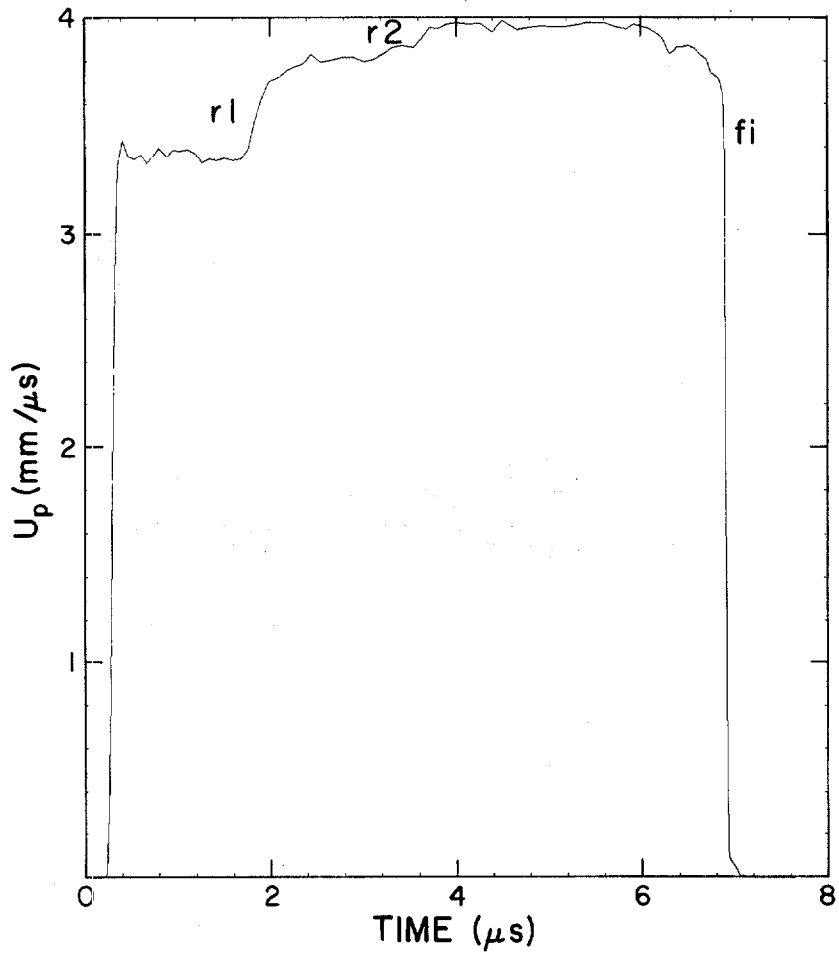

TARGET **Material:** PBX 9404 - 6061 aluminum free-run system
Experiment type: ASM probe
Experimenters: J. N. Fritz and J. A. Morgan
Shot no.: M 91 **Date:** May 21, 1974

HE SHOT GEOMETRY Plane wave lens/25 mm PBX 9404/5.33 mm Lucite/
12.7 mm PBX 9404/3.19 mm 6061 aluminum//38.3 mm
air/Pyrex glass//

SHOT COMPONENTS PBX 9404
Density: 1.830 g/cm³
C_L = 2.90 mm/μs C_S = 1.57 mm/μs
Lucite
Density: 1.184 g/cm³
C_L = 2.69 mm/μs C_S = 1.38 mm/μs
6061 aluminum
Density: 2.703 g/cm³
C_L = 6.40 mm/μs C_S = 3.15 mm/μs

TRANSDUCER ASM probe
Coil radius: 86.70 mm **Initial coil spacing:** 41.44 mm
Time: Relative

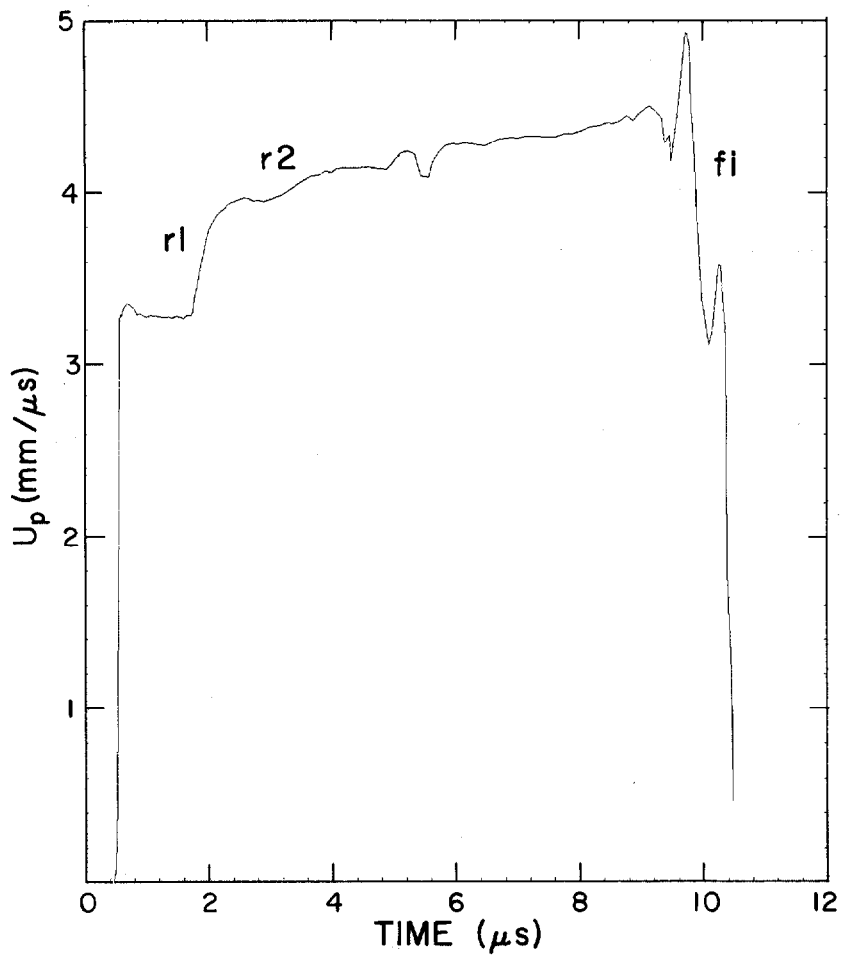

TARGET

Material: PBX 9404 - copper free-run system
Experiment type: ASM probe
Experimenters: J. N. Fritz and J. A. Morgan
Shot no.: M 85 **Date:** May 23, 1973

HE SHOT GEOMETRY

P-040 lens/25 mm PBX 9404/2.48 mm OFHC copper//
10.15 mm air/5.16 mm Pyrex glass//

SHOT COMPONENTS

PBX 9404

Density: 1.830 g/cm³

$C_L = 2.90$ mm/ μ s $C_S = 1.57$ mm/ μ s

OFHC copper

Density: 8.93 g/cm³

$C_L = 4.76$ mm/ μ s $C_S = 2.33$ mm/ μ s

TRANSDUCER

ASM probe

Coil radius: 28.64 mm **Initial coil spacing:** 15.31 mm

Time: Relative

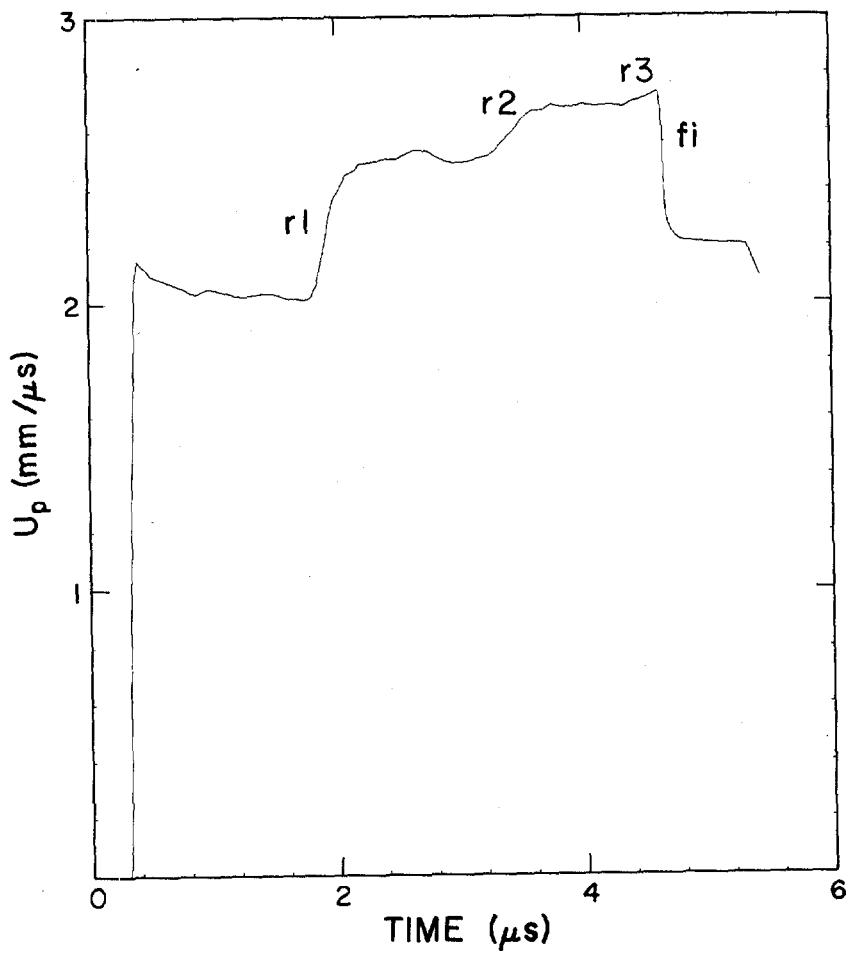

TARGET

Material: PBX 9404 - copper free-run system
Experiment type: ASM probe
Experimenters: J. N. Fritz and J. A. Morgan
Shot no.: M 92 **Date:** May 24, 1974

HE SHOT GEOMETRY

Plane wave lens/25.4 mm PBX 9404/5.33 mm Lucite/
12.7 mm PBX 9404/2.41 mm OFHC copper//38.1 mm
air/ Pyrex glass//

SHOT COMPONENTS

PBX 9404

Density: 1.830 g/cm³

$C_L = 2.90$ mm/ μ s $C_S = 1.57$ mm/ μ s

Lucite

Density: 1.184 g/cm³

$C_L = 2.69$ mm/ μ s $C_S = 1.38$ mm/ μ s

OFHC copper

Density: 8.93 g/cm³

$C_L = 4.76$ mm/ μ s $C_S = 2.33$ mm/ μ s

TRANSDUCER

ASM probe

Coil radius: 86.7 mm **Initial coil spacing:** 41.3 mm

Time: Relative

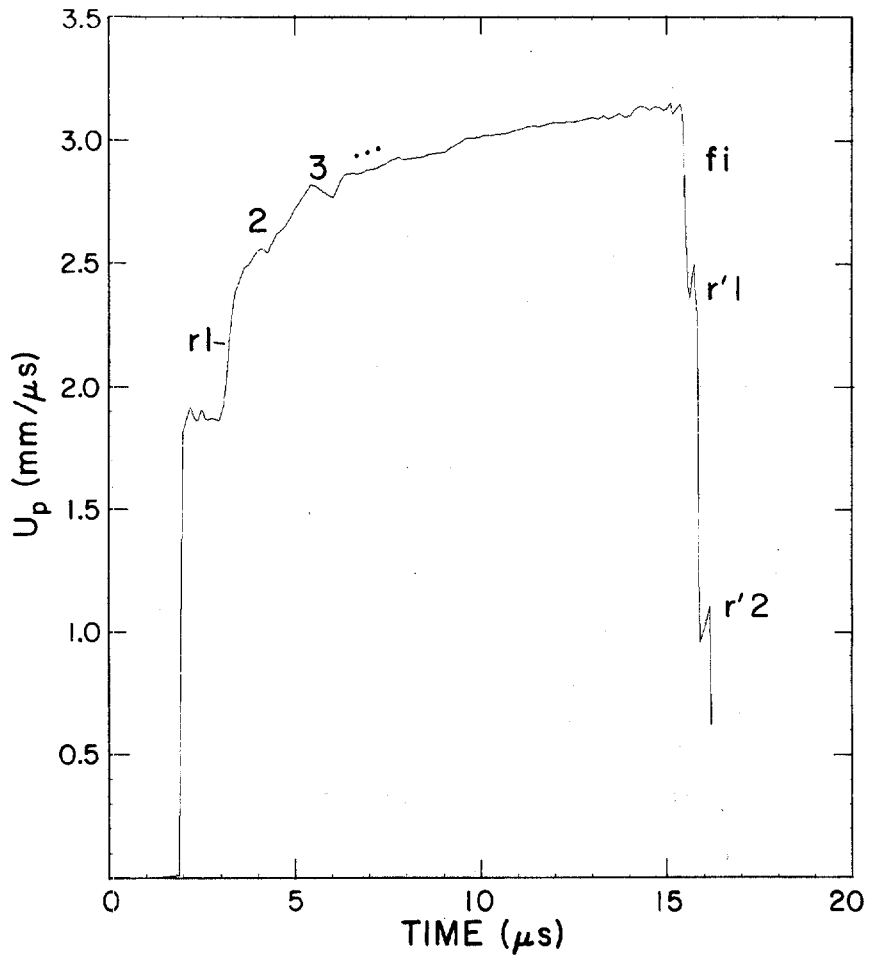

TARGET

Material: PBX 9404 - 304 stainless steel free-run system
Experiment type: ASM probe
Experimenters: J. N. Fritz and J. A. Morgan
Shot no.: M 71 **Date:** September 29, 1972

HE SHOT GEOMETRY

P-081 lens/38 mm PBX 9404/12.7 mm vacuum/1.932 mm
304 stainless steel/20.0 mm vacuum/6.42 mm
polymethyl methacrylate//

SHOT COMPONENTS

PBX 9404
Density: 1.830 g/cm³
 $C_L = 2.90$ mm/ μ s $C_S = 1.57$ mm/ μ s
304 stainless steel
Density: 7.890 g/cm³
 $C_L = 5.77$ mm/ μ s $C_S = 3.12$ mm/ μ s

TRANSDUCER

ASM probe
Coil radius: 38.17 mm **Initial coil spacing:** 26.42 mm
Time: Relative

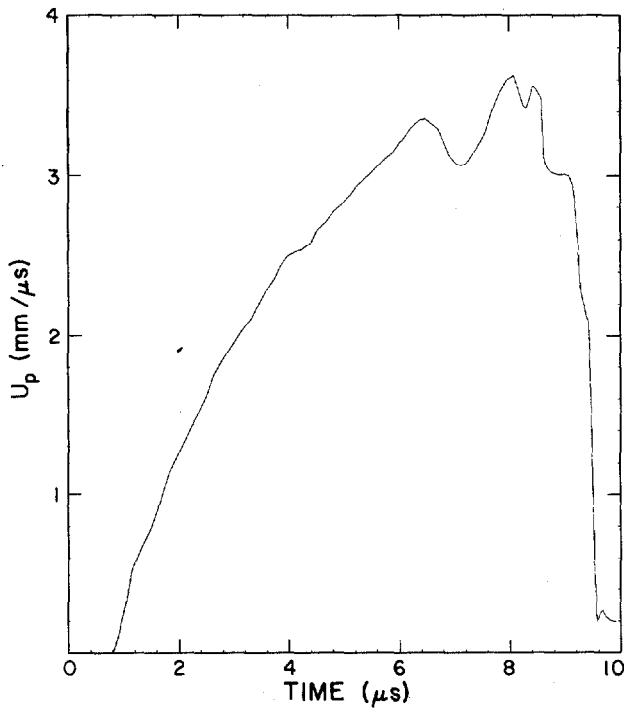

TARGET

Material: PBX 9404 - 304 stainless steel free-run system
Experiment type: ASM probe
Experimenters: J. N. Fritz and J. A. Morgan
Shot no.: M 76 **Date:** December 20, 1972

HE SHOT GEOMETRY

P-081 lens/38 mm PBX 9404/12.8 mm vacuum/1.93 mm
304 stainless steel//12.75 mm vacuum/5.15 mm
polymethyl methacrylate//

SHOT COMPONENTS

PBX 9404
Density: 1.830 g/cm³
 $C_L = 2.90$ mm/ μ s $C_S = 1.57$ mm/ μ s
304 stainless steel
Density: 7.890 g/cm³
 $C_L = 5.77$ mm/ μ s $C_S = 3.12$ mm/ μ s

TRANSDUCER

ASM probe
Coil radius: 28.64 mm **Initial coil spacing:** 17.90 mm
Time: Relative

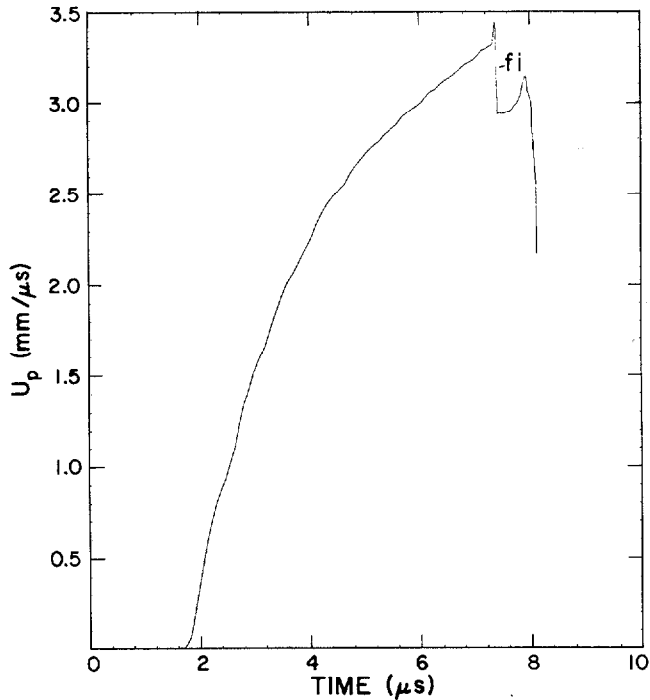

TARGET

Material: PBX 9404 - Lexan free-run system
Experiment type: ASM probe
Experimenters: J. N. Fritz and J. A. Morgan
Shot no.: M 55 **Date:** January 5, 1972

HE SHOT GEOMETRY

P-081 lens/152 mm PBX 9404/6.35 mm air/6.16 mm Lexan/0.03 mm aluminum//25.34 mm air//

SHOT COMPONENTS

PBX 9404
Density: 1.830 g/cm³
 $C_L = 2.90$ mm/ μ s $C_S = 1.57$ mm/ μ s

TRANSDUCER

ASM probe
Coil radius: 28.64 mm **Initial coil spacing:** 25.34 mm
Time: Relative

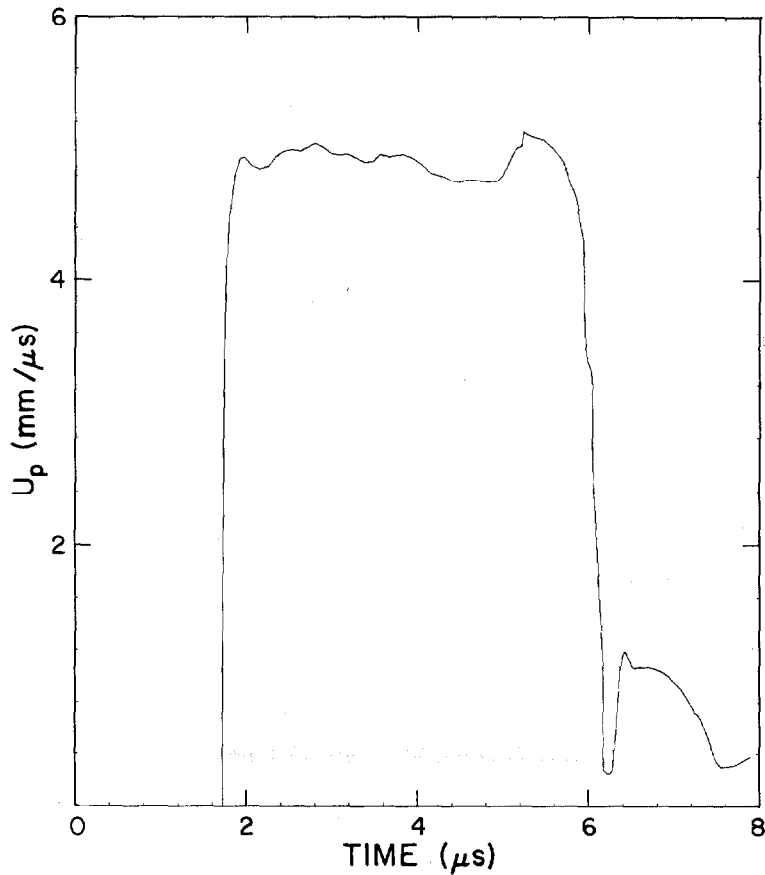

TARGET

Material: PBX 9404 - polyethylene free-run system
Experiment type: ASM probe
Experimenters: J. N. Fritz and J. A. Morgan
Shot no.: C 4179 Date: May 20, 1972

HE SHOT GEOMETRY

P-081 lens/38 mm PBX 9404/6.38 mm polyethylene/
2.54 mm gold//2.54 mm polyethylene//

SHOT COMPONENTS

PBX 9404
Density: 1.830 g/cm³
C_L = 2.90 mm/μs C_S = 1.57 mm/μs
Polyethylene
Density: 0.916 g/cm³
C_L = 2.04 mm/μs C_S = 0.66 mm/μs

TRANSDUCER

ASM probe
Coil radius: 9.58 mm Initial coil spacing: 2.54 mm
Time: Relative

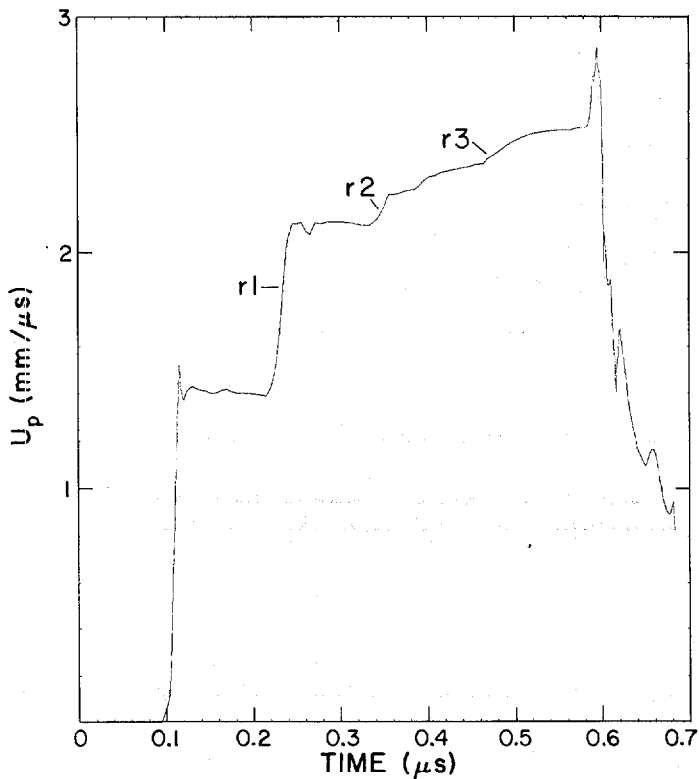

REFERENCES

Dennison Bancroft, Eric L. Peterson, and Stanley Minshall, "Polymorphism of Iron at High Pressure," *J. Appl. Phys.* **27**, 291-298 (1956).

L. M. Barker and R. E. Hollenbach, "Laser Interferometer for Measuring High Velocities of Any Reflecting Surface," *J. Appl. Phys.* **43**, 4669-4675 (1972).

L. W. Bickle, R. P. Reed, and N. R. Keltner, "Numerical Time Domain Convolution and Deconvolution Applied to Quartz Gage Stress Data," Sandia Laboratories report SC-DR-71-0650 (1971).

Francis Birch, "The Velocity of Compressional Waves in Rocks to 10 Kilobars, Part 1," *J. Geophys. Res.* **65** 1083-1102 (1960).

W. C. Davis, "Magnetic Probe Measurements of Particle Velocity Profiles," in *Sixth Symposium (International) on Detonation*, Coronado, California, August 24-27, 1976 (Office of Naval Research ACR-221, 1976), pp. 637-641.

W. C. Davis and B. G. Craig, "Smear Camera Technique for Free-Surface Velocity Measurement," *Rev. Sci. Instrum.* **32**, 579-581 (1961).

Russell E. Duff and F. Stanley Minshall, "Investigation of a Shock-Induced Transition in Bismuth," *Phys. Rev.* **108**, 1207-1212 (1957).

C. M. Fowler, F. Stanley Minshall, and E. G. Zukas, "A Metallurgical Method for Simplifying the Determination of Hugoniot Curves for Iron Alloys in the Two-Wave Region," in *Response of Metals to High Velocity Deformation*, P. G. Shewmon and V. F. Zackay, Eds., Metallurgical Society Conferences, Estes Park, Colorado, July 11-12, 1960, Vol. 9 (Interscience Publishers, New York, 1961), pp. 275-308.

G. R. Fowles, "Shock-Wave Compression of Quartz," doctoral thesis, Department of Geophysics, Stanford University, 1962.

J. N. Fritz and J. A. Morgan, "An Electromagnetic Technique for Measuring Material Velocity," *Rev. Sci. Instrum.* **44**, 215-221 (1973).

P. J. A. Fuller and J. H. Price, "Electrical Conductivity of Manganin and Iron at High Pressures," *Nature* **193**, 262-263 (1962).

R. A. Graham and G. E. Ingram, "Piezoelectric Current from X-Cut Quartz Shock-Loaded from 25 to 70 kbar," *Bull. Am. Phys. Soc.* **14**, 1163 (1969).

R. A. Graham, F. W. Neilson, and W. B. Benedick, "Piezoelectric Current from Shock-Loaded Quartz—A Submicrosecond Stress Gauge," *J. Appl. Phys.* **36**, 1775-1783 (1965).

P. M. Halleck and Jerry Wackerle, "Dynamic Elastic-Plastic Properties of Single-Crystal Pentaerythritol Tetranitrate," *J. Appl. Phys.* **47**, 976-981 (1976).

W. J. Halpin, O. E. Jones, and R. A. Graham, "A Submicrosecond Technique for Simultaneous Observation of Input and Propagated Impact Stresses," in *Symposium on Dynamic Behavior of Materials*, Albuquerque, New Mexico, September 27-28, 1962 (American Society for Testing and Materials Special Publication No. 336, 1963), pp. 208-217.

B. Hayes and J. N. Fritz, "Measurement of Mass Motion in Detonation Products by an Axially Symmetric Electromagnetic Technique," in *Fifth Symposium (International) on Detonation*, Pasadena, California, August 1970 (Office of Naval Research ACR-184, 1970), pp. 447-454.

G. E. Ingram and R. A. Graham, "Quartz Gauge Technique for Impact Experiments," in *Fifth Symposium (International) on Detonation*, Pasadena, California, August 1970 (Office of Naval Research ACR-184, 1970), pp. 369-386.

C. L. Mader, *Numerical Modeling of Detonation* (University of California Press, 1979).

Robert G. McQueen, "Laboratory Techniques for Very High Pressures and the Behavior of Metals Under Dynamic Loading," in *Metallurgy at High Pressures and High Temperatures*, K. A. Gschneidner, Jr., M. T. Hepworth, and N. A. D. Parlee, Eds., Metallurgical Society Conferences, Dallas, Texas, February 25-26, 1963, Vol. 22 (Gordon and Breach, New York, 1964), pp. 44-129.

R. G. McQueen, S. P. Marsh, J. W. Taylor, J. N. Fritz, and W. J. Carter, "The Equation of State of Solids from Shock Wave Studies," in *High-Velocity Impact Phenomena*, Ray Kinslow, Ed. (Academic Press, New York, 1970).

Stanley Minshall, "Properties of Elastic and Plastic Waves Determined by Pin Contactors and Crystals," *J. Appl. Phys.* **26**, 463-469 (1955).

F. S. Minshall, communication to R. G. McQueen regarding unpublished data, 1962.

F. Stanley Minshall, "The Dynamic Response of Iron and Iron Alloys to Shock Waves," in *Response of Metals to High Velocity Deformation*, P. G. Shewmon and V. F. Zackay, Eds., Metallurgical Society Conferences, Estes Park, Colorado, July 11-12, 1960, Vol. 9 (Interscience Publishers, New York, 1961), pp. 249-274.

C. E. Morris, unpublished data, March 1981.

J. A. Morgan and J. N. Fritz, "Sound Velocity on SiO₂ Hugonions," in *High Pressure Science and Technology*, K. D. Timmerhaus and M. S. Barber, Eds., Metallurgical Society Conferences, Boulder, Colorado, July 25-29, 1977, Vol. 2 (Plenum Publishing Corporation, New York, 1979), pp. 109-117.

F. W. Neilson, in open discussion in *Response of Metals to High Velocity Deformation*, P. G. Shewmon and V. F. Zackay, Eds., Metallurgical Society Conferences, Estes Park, Colorado, July 11-12, 1960, Vol. 9 (Interscience Publishers, New York, 1961), p. 273.

M. H. Rice, "Capacitor Technique for Measuring the Velocity of a Plane Conducting Surface," *Rev. Sci. Instrum.* **32**, 449-451 (1961).

M. H. Rice, "Calibration of the Power Supply for Manganin Pressure Gages," Air Force Weapons Laboratory, Kirtland AFB, New Mexico, Technical Report AFWL-TR-70-120 (November 1970).

Edward Schreiber, Orson L. Anderson, and Naohiro Soga, "The Determination of Velocity of Propagation," in *Elastic Constants and Their Measurement* (McGraw-Hill Book Co., New York, 1973).

Lynn Seaman, "Lagrangian Analysis for Multiple Stress or Velocity Gages in Attenuating Waves," *J. Appl. Phys.* **45**, 4303-4314 (1974).

D. J. Steinberg and D. L. Banner, "Accounting for Resistive Hysteresis in Calibrating Manganin Stress Gauges Undergoing Dynamic Loading," *J. Appl. Phys.* **50**, 235-238 (1979).

John W. Taylor, "Dislocation Dynamics and Dynamic Yielding," *J. Appl. Phys.* **36**, 3146-3150 (1965).

J. W. Taylor, "Stress Wave Profiles in Several Metals," in *Dislocation Dynamics*, Alan R. Rosenfield, George T. Hahn, Arden L. Bement, Jr., and Robert I. Jaffee, Eds. (McGraw-Hill Book Company, New York, 1968).

J. W. Taylor, "Experimental Methods in Shock Wave Physics," in *Metallurgical Effects at High Strain Rates*, R. W. Rohde, B. M. Butcher, J. R. Holland, and C. H. Karnes, Eds. (Plenum Publishing Company, New York, 1973), pp. 107-126. John W. Taylor and Melvin H. Rice, "Elastic-Plastic Properties of Iron," *J. Appl. Phys.* **34**, 364-371 (1963).

Harry Vantine, John Chan, Leroy Erickson, James Janzen, Richard Weingart, and Ron Lee, "Precision Stress Measurements in Severe Shock-Wave Environments with Low-Impedance Manganin Gages," *Rev. Sci. Instrum.* **51**, 116-122 (1980).

Jerry Wackerle and James O. Johnson, "Pressure Measurements on the Shock-Induced Decomposition of High Density PETN," Los Alamos Scientific Laboratory report LA-5131 (November 1973).

Jerry Wackerle, J. O. Johnson, and P. M. Halleck, "Projectile-Velocity Measurements and Quartz- and Manganin-Gauge Pressure Determinations in Gas-Gun Experiments," Los Alamos Scientific Laboratory report LA-5844 (1975a).

Jerry Wackerle, J. O. Johnson, and P. M. Halleck, "Shock Compression and Initiation of Porous PETN," *Bull. Am. Phys. Soc.* **20**, 20-21 (1975b).

Jerry Wackerle, J. O. Johnson, and P. M. Halleck, "Shock Initiation of High-Density PETN," in *Sixth Symposium (International) on Detonation*, Coronado, California, August 24-27, 1976 (Office of Naval Research, ACR-221, 1976), pp. 20-28.

Jerry Wackerle, R. L. Rabie, M. J. Ginsberg, and A. B. Anderson, "A Shock Initiation Study of PBX 9404," *Proc. of Symposium on High Dynamic Pressures*, Paris, August 27-31, 1978 (Commissariat à l'Energie Atomique, Centre d'Etudes de Nucléaires de Saclay, 1978), pp. 127-138.

GLOSSARY

- ASM** axially symmetric magnetic probe
- AIVC8** a corundum mixture
- C_L, C_S** longitudinal and shear plane wave velocities
- CEF** tris-beta chloroethylphosphate
- Comp B** 59.5 wt% RDX, 39.5 wt% TNT, and 1.0 wt% wax
- Comp B-3** 60.0 wt% RDX, 40.0 wt% TNT, and 0.0 wt% wax

Graph Symbols

- bw:** bulk wave arrivals
- bwr:** bulk wave release
- comp:** complex signal interpretation
- dirt:** diffusion-limited rise time; a slightly conductive layer between the surface and the probe retards the interface signal
- en:** electronic nonsense associated with 0.15- μ s round-trip travel time through cable and/or electronic unfolding
- ew:** elastic wave arrivals
- ewr:** elastic wave release

- f1, f2, f3...:** fiducials for wave arrivals; although an ~50-nm aluminum film does not significantly impede magnetic field motion, when it is subjected to large accelerations associated with shock arrivals at free surfaces and interfaces, the film causes a blip in the voltage record
- fg:** real "flash-gap" structure; the first point indicates the gas in the gap striking a plastic anvil, giving the gas layer sufficient conductivity to slightly impede the lines-of-force motion, resulting in only a slight decrease in the analyzed velocity; when the plastic burns off and diffuses, the conductivity is reduced and the force lines are unretarded, giving the pip in the record before impact
- fi:** fiducial impact; a free surface has moved through a gap (usually air) and has impacted a layer at a known initial distance from the conducting surface
- n1:** a jitter in the records caused by electronic corrections after failure to get proper terminations in the recording circuits
- n2:** surface conductivity of a thin film did not hold for the experiment
- 2ph:** phase transitions cause single shocks to split into a two-wave structure
- pi:** imperfect contact causes a small pip of velocity until the next downstream layer is reached (a glue joint or a small intervening air gap arc causes)
- r1, r2, r3...:** a reverberation through a layer; a shock or a release propagates through a metal or other layer, interacts with a material of different impedance, then propagates forward or backward as a shock or release, showing up as an increased or decreased surface velocity
- sp:** possible spall indication
- twr:** transition wave release

HE shot geometry the configuration in which a high-explosive shot assembly was fired; the *ld* layers are separated by a slash (/); the first double slash (//) indicates the surface on which the probe is focused; the second double slash indicates the location of the first element of the probe (either coil or magnet), with the coil and the front face of the magnet usually at the same level; two layers glued together are shown by /epoxy/, and material/material indicates that the layers are only butted together; the symbol -f/ describes a thin (~50-75-nm) aluminum film deposited on the right side of the material; /f- describes conversely the same film deposited on the left side of the material

Kel-F	a trademark for a series of chlorofluoroethylene polymers and copolymers
Kapton	a trademark for a polyimide film (1-5 mils thick)
Lexan	a trademark for a thermoplastic carbonate-linked polymer
NC	nitrocellulose, $C_6H_7O_2(ONO_2)_3$
OFHC	oxygen-free high-conductivity copper
PETN	pentaerythritol tetranitrate, $C_5H_8N_4O_{12}$
PBX 9404	94.0 wt% HMX, 3.0 wt% NC, 3.0 wt% CEF, 0.1 wt% diphenylamine (DPA)
PBX 9501	95.0 wt% HMX, 2.5 wt% Estane, and 2.5 wt% BDNPA/BDNPF nitroplasticizers
PBX 9502	95 wt% TATB and 5 wt% Kel-F 800
P-081 lens	a conical explosive lens with a base of 8.1 in., designed to generate a plane detonation
P-120 lens	a conical explosive lens with a base of 12.0 in., designed to generate a plane detonation
Pentek	a trademark for pentaerythritol, technical
PMMA	any of several polymethyl methacrylates
Rc	a hardness number on the Mohs scale
TATB	1,3,5-trinitrobenzene
TNT	2,4,6-trinitrotoluene, $C_7H_5N_3O_6$

APPENDIX

HUGONIOT ELASTIC LIMITS

Material	Elastic Limit (GPa)	Sample Thickness (mm)	Technique ^a
ELEMENTS			
beryllium	0 (ramp)	all	fsc
beryllium, single crystal, basal plane	0.3	---	fsc
beryllium, single crystal, C-axis	4.4	---	fsc
boron	8.6	6	fsc
copper, annealed	0 (ramp)	all	fsc
copper, 50% cold-worked	0.6	12	fsc
chromium	1.6	5	ol
germanium, single crystal [100]	5.2	8	ol
germanium, single crystal [100]	5.4	---	fsc
germanium, single crystal [111]	3.7	10	ol
germanium, single crystal [114]	4.0	10	ol
iron, Armco	1.9→0.5	1.5→50	fsc
iron, fine-grain hard	1.5	3	ol
iron, large-grain hard	1.4	3	ol
iron, fine-grain soft	1.1	3	ol
iron, large-grain soft	0.9	3	ol
lead, annealed	0 (ramp)	13	fsc
molybdenum	1.6	3	ol

^aFree-surface capacitor technique is denoted by fsc; optical lever technique is denoted by ol.

HUGONIOT TABLE (cont)

Material	Elastic Limit (GPa)	Sample Thickness (mm)	Technique ^a
nickel	1.0	12	fsc
niobium	2.1	12	fsc
silicon, single crystal [100]	6.8	10	ol
silicon, single crystal [100]	8.2	8	fsc
silicon, single crystal [110]	6.7	10	ol
silicon, single crystal [111]	6.0	10	ol
tantalum	1.4	10	fsc
thorium	0.2	25	fsc
tin	0.3	9	fsc
titanium	1.5	10	fsc
titanium	1.9	12	fsc
tungsten	4.5	5	fsc
tungsten	3.2	5	ol
uranium	0 (ramp)	all	fsc
zirconium	1.9	6	fsc
ALLOYS			
aluminum, 2024	0.6	13	fsc
aluminum, 6061	0.6	13	fsc
98.2 wt% copper/1.8 wt% beryllium, annealed	1.5	6	fsc
98 wt% gold/2 wt% copper	0.9	8	fsc
magnesium (AZ-31B)	0.2	13	fsc
95 wt% molybdenum/5 wt% rhenium	1.6	9	fsc
steel, 1018 at 101°C	1.3	13	fsc
steel, 1018	1.4	13	fsc
steel, 1045	2.4	18	fsc
steel, 1095	2.1	16	fsc
steel, 4150; Rc = 62	3.7	13	fsc
steel, maraging, Almar 360	1.7	6	fsc
steel, maraging, HP 9-4-20	1.4	6	fsc
steel, HY 80 naval armor steel	1.7	13	fsc
steel, maraging, Vascomax 250	2.8	13	fsc
steel, maraging, Vascomax 300	2.8	9	fsc
steel, stainless A-256 Austenitic	1.4	10	fsc
steel, stainless 304	0.2	8	fsc

HUGONIOT TABLE (cont)

Material	Elastic Limit (GPa)	Sample Thickness (mm)	Technique ^a
steel, stainless 21-6-9	1.1	7	fsc
90 wt% tantalum/10 wt% tungsten, annealed at 1450°C	3.2	6	fsc
tungsten	4.0	12	fsc
tungsten carbide, Kennametal Grade K8	4.6	13	fsc
98.5 wt% tungsten/0.5 wt% nickel/1 wt% iron	2.4	13	fsc
95 wt% tungsten/2.1 wt% nickel/1.4 wt% iron/ 1.5 wt% cobalt	2.3	13	fsc
95 wt% tungsten/3.5 wt% nickel/1.5 wt% iron	3.1	13	fsc
75 wt% tungsten/25 wt% rhenium	5.5	11	fsc
91 wt% tungsten/5 wt% rhenium/1.4 wt% platinum/1.4 wt% nickel/1.2 wt% iron	3.2	13	fsc
98 wt% uranium/2 wt% molybdenum	2.1	10	fsc
97.03 wt% uranium/1.16 wt% niobium/ 1.81 wt% titanium	1.8	10	fsc
99.16 wt% uranium/0.84 wt% titanium	1.9	3	fsc
98.82 wt% uranium/1.18 wt% titanium	2.0	9	fsc
MINERALS AND COMPOUNDS			
85 wt% alumina ceramic (porous, $\rho_0 = 3.40 \text{ g/cm}^3$)	4.5	12	fsc
alumina (porous, $\rho_0 = 3.39 \text{ g/cm}^3$)	4.4	13	fsc
alumina (porous, $\rho_0 = 3.50 \text{ g/cm}^3$)	7.2	13	fsc
beryllium oxide	8.5	13	fsc
boron carbide	9.9	8	fsc
boron nitride (porous, $\rho_0 = 2.02 \text{ g/cm}^3$)	0 (ramp)	13	fsc
hafnium titanate ($\rho_0 = 6.96 \text{ g/cm}^3$)	1.3	13	fsc
jadeite	6.5	10	ol
lithium hydride	0.1	13	fsc
magnesium aluminum oxide, spinel	7.3	8	fsc
magnesia, single crystal	4.0	10	ol
titanium boride ($\rho_0 = 4.3 \text{ g/cm}^3$)	5.9	10	fsc
titanium boride ($\rho_0 = 4.5 \text{ g/cm}^3$)	8.6	10	fsc
zirconium boride	7.5	10	fsc

**LONGITUDINAL AND SHEAR WAVE VELOCITIES
IN POLYCRYSTALLINE AGGREGATES**

	Density (g/cm ³)	C _L (mm/μs)	C _S (mm/μs)		Density (g/cm ³)	C _L (mm/μs)	C _S (mm/μs)
1 barium	3.661	2.16	1.28	53 uranium (extrapolation of molybdenum and rhodium alloy data)	19.000	3.45	2.12
2 beryllium, sintered	1.851	13.15	8.97	54 ytterbium	7.031	1.94	1.12
3 bismuth	9.808	2.49	1.43	55 yttrium	4.565	4.38	2.52
4 boron, hot-pressed	2.334	13.90	9.00	56 zirconium	6.510	4.77	2.39
5 cadmium	8.642	3.20	1.65	57 aluminum 1100	2.715	6.38	3.16
6 calcium	1.536	4.39	2.49	58 aluminum 2014	2.810	6.39	3.17
7 carbon (M-3 graphite), sintered	1.807	2.56	1.52	59 aluminum 2024	2.785	6.36	3.16
8 carbon, vitreous	1.492	4.59	2.91	60 aluminum 2024, sintered	2.507	5.26	2.80
9 cerium	6.731	2.33	1.34	61 aluminum 2024, sintered	2.287	4.60	2.55
10 cobalt	8.821	5.73	3.04	62 aluminum 2024, sintered	2.158	4.05	2.28
11 copper, OFHC	8.929	4.76	2.33	63 aluminum 2024, sintered	1.947	3.46	1.96
12 copper, sintered	7.903	4.23	2.19	64 aluminum 2024, sintered	1.706	2.82	1.53
13 copper, sintered	7.365	3.95	2.07	65 aluminum 6061	2.703	6.40	3.15
14 copper, sintered	7.197	3.77	2.01	66 aluminum 921T	2.813	6.29	3.11
15 copper, sintered	6.428	3.30	1.80	67 brass (J-1), free-machining, high-leaded	8.450	4.41	2.13
16 copper, sintered	6.249	3.20	1.79	68 Carboly, 86.3 wt% Ni/ 7.1 wt% W/5.7 wt% C/ 0.8 wt% Fe/0.1 wt% Co	14.720	6.85	4.14
17 copper, sintered	5.603	2.68	1.52	69 Dowmetal	1.779	5.84	3.09
18 copper, sintered	4.504	1.83	1.07	70 Fansteel 77	17.480	5.10	2.80
19 dysprosium	8.410	3.07	1.78	71 gold/5.8 wt% germanium	16.880	3.33	1.33
20 erbium	9.058	3.13	1.84	72 gold/9.3 wt% germanium	15.490	3.39	1.47
21 gadolinium	7.785	2.95	1.69	73 gold/20.6 wt% lead	16.950	2.98	1.19
22 gold	19.240	3.25	1.19	74 gold/33.5 wt% lead	16.010	2.85	1.15
23 hafnium	12.890	3.86	2.12	75 iron/40 wt% cobalt	8.102	6.20	3.66
24 holmium	8.750	3.21	1.86	76 iron/10 wt% nickel	7.883	5.76	3.16
25 iridium	22.500	5.32	3.29	77 iron/18 wt% nickel	7.962	5.56	2.94
26 iron	7.870	5.94	3.26	78 iron/20 wt% nickel	7.970	6.62	3.81
27 iron, sintered	6.913	5.36	3.00	79 iron/26 wt% nickel	7.974	5.38	2.72
28 iron, sintered	5.925	4.55	2.37	80 iron/25 wt% silicon	6.632	6.87	3.88
29 lanthanum	6.136	2.69	1.51	81 iron/10 wt% vanadium	7.706	6.30	3.70
30 lead	11.340	2.25	0.89	82 magnesium/AZ31B	1.780	5.70	3.05
31 magnesium	1.740	5.74	3.15	83 magnesium/14 wt% Li/ 1 wt% Al	1.403	6.35	4.17
32 molybdenum	10.200	6.45	3.48	84 plutonium/1.0 wt% gallium (92/8 wt% delta/alpha)	16.040	1.93	1.15
33 neodymium	6.986	2.84	1.60	85 plutonium/1.0 wt% gallium (delta)	15.760	1.90	1.07
34 nickel	8.882	5.79	3.13	86 steel 304 (stainless)	7.890	5.77	3.12
35 palladium	12.000	4.68	2.33	87 steel 304L (stainless)	7.903	5.79	3.16
36 platinum	21.430	4.08	1.76	88 steel 348 (stainless)	7.928	5.74	3.12
37 plutonium (alpha)	19.600	2.34	1.47	89 steel 1018	7.861	5.92	3.19
38 praseodymium	6.764	2.74	1.51	90 steel 1095	7.860	5.90	3.21
39 rhenium	20.990	5.30	2.89	91 steel 4150	7.785	5.89	3.20
40 rhodium	12.430	6.00	3.64	92 steel, Vega, A6 tool steel	7.835	5.82	3.18
41 samarium	7.464	2.88	1.64	93 uranium/0.50 wt% molyb- denum (furnace-cooled)	18.910	3.44	2.08
42 scandium	3.195	5.57	3.07	94 uranium/0.97 wt% molyb- denum (furnace-cooled)	18.810	3.38	2.02
43 silicon	2.330	9.04	5.40				
44 silver	10.490	3.71	1.66				
45 strontium	2.585	2.70	1.45				
46 tantalum	16.690	4.16	2.09				
47 terbium	8.202	2.94	1.69				
48 thorium	11.680	2.95	1.57				
49 thulium	9.268	3.02	1.77				
50 tin	7.291	3.43	1.77				
51 titanium	4.517	6.16	3.19				
52 tungsten	19.270	5.22	2.88				

TABLE (cont)

	Density (g/cm ³)	C _L (mm/μs)	C _S (mm/μs)		Density (g/cm ³)	C _L (mm/μs)	C _S (mm/μs)
95 uranium/1.95 wt% molybdenum (furnace-cooled)	18.610	3.33	1.94	124 beryllium oxide (BeO), sintered	2.660	10.24	6.37
96 uranium/2.92 wt% molybdenum (furnace-cooled)	18.450	3.33	1.89	125 beryllium oxide (BeO), sintered	2.439	9.06	5.63
97 uranium/3.30 wt% molybdenum (furnace-cooled)	18.330	3.29	1.82	126 corundum (Al ₂ O ₃), Lucalox	3.974	10.85	6.41
98 uranium/4.00 wt% molybdenum (furnace-cooled)	18.250	3.27	1.75	127 corundum (Al ₂ O ₃), sintered	3.833	10.51	6.19
99 uranium/4.47 wt% molybdenum (furnace-cooled)	18.150	3.23	1.72	128 corundum (Al ₂ O ₃), sintered	3.107	6.18	3.87
100 uranium/4.72 wt% molybdenum (furnace-cooled)	17.980	2.94	1.23	129 corundum (Al ₂ O ₃), sintered	2.834	4.88	3.08
101 uranium/5.37 wt% molybdenum (furnace-cooled)	17.820	2.94	1.20	130 corundum (Al ₂ O ₃), sintered	2.563	1.76	1.17
102 uranium/6.82 wt% molybdenum (furnace-cooled)	17.590	3.01	1.25	131 hematite (Fe ₂ O ₃), natural	4.976	7.78	4.02
103 uranium/8.31 wt% molybdenum (furnace-cooled)	17.320	3.08	1.32	132 ilmenite (FeTiO ₃), Krageroe, Norway	4.817	7.16	2.90
104 uranium/8.79 wt% molybdenum (furnace-cooled)	17.370	3.10	1.33	133 lithium hydride (enriched lithium, 95.5 at.% ⁶ Li)	0.698	10.67	7.18
105 uranium/0.97 wt% molybdenum (water-quenched)	18.770	3.32	1.93	134 lithium hydride (enriched lithium, 95.5 at.% ⁶ Li)	0.666	10.42	6.86
106 uranium/1.95 wt% molybdenum (water-quenched)	18.530	3.12	1.68	135 lithium deuteride (enriched lithium, 95.5 at.% ⁶ Li)	0.799	10.10	6.80
107 uranium/2.92 wt% molybdenum (water-quenched)	18.300	3.12	1.61	136 lithium deuteride (enriched lithium, 95.5 at.% ⁶ Li)	0.764	9.72	6.53
108 uranium/4.00 wt% molybdenum (water-quenched)	18.130	3.05	1.42	137 lithium hydride (normal lithium, 7.5 at.% ⁶ Li)	0.782	10.05	6.75
109 uranium/4.47 wt% molybdenum (water-quenched)	18.020	3.01	1.43	138 lithium hydride (normal lithium, 7.5 at.% ⁶ Li)	0.743	9.84	6.61
110 uranium/4.72 wt% molybdenum (water-quenched)	17.960	2.89	1.17	139 lithium deuteride (normal lithium, 7.5 at.% ⁶ Li)	0.894	9.56	6.43
111 uranium/5.37 wt% molybdenum (water-quenched)	17.820	2.95	1.21	140 lithium deuteride (normal lithium, 7.5 at.% ⁶ Li)	0.840	9.36	6.31
112 uranium/6.82 wt% molybdenum (water-quenched)	17.610	3.00	1.21	141 magnetite (Fe ₃ O ₄), natural	5.118	7.00	3.32
113 uranium/8.79 wt% molybdenum (water-quenched)	17.360	3.07	1.29	142 periclase (MgO), hot-pressed	3.575	9.71	6.02
114 uranium/6 wt% niobium	17.390	2.90	1.23	143 periclase (MgO), sintered	3.457	9.37	5.83
115 uranium/1.1 wt% rhodium	18.820	3.45	2.07	144 periclase (MgO), sintered	3.020	8.23	5.08
116 uranium/5.4 wt% rhodium	18.330	3.41	1.94	145 phenanthrene (C ₁₄ H ₁₀), pressed	1.212	2.78	1.42
117 uranium/13.4 wt% rhodium	17.260	3.38	1.74	146 pyrene (C ₁₆ H ₁₀), pressed	1.275	2.64	1.18
118 Wood's metal	9.685	2.46	1.11	147 quartz (SiO ₂), fused	2.204	5.96	3.77
119 andalusite (Al ₂ SiO ₅), natural	3.073	7.30	4.31	148 silicon carbide (SiC)	3.121	11.73	7.43
120 anthracene, pressed	1.249	2.92	1.52	149 sillimanite (Al ₂ SiO ₅), Dillon, Montana	3.172	9.00	4.95
121 beryllium oxide (BeO), sintered	2.989	11.91	7.28	150 sodium chloride (NaCl), pressed	2.137	4.47	2.57
122 beryllium oxide (BeO), sintered	2.866	11.45	7.02	151 spinel (MgAl ₂ O ₄), hot-pressed	3.561	9.70	5.50
123 beryllium oxide (BeO), sintered	2.816	10.94	6.77	152 spinel (MgAl ₂ O ₄), hot-pressed	3.493	9.52	5.40
				153 spinel (MgAl ₂ O ₄), sintered	3.409	9.41	5.34
				154 spinel (MgAl ₂ O ₄), sintered	3.330	9.19	5.25
				155 spinel (MgAl ₂ O ₄), sintered	3.260	8.99	5.15
				156 uranium dioxide (UO ₂), sintered	10.510	5.17	2.68
				157 uranium dioxide (UO ₂), sintered	10.300	5.01	2.63

TABLE (cont)

	Density (g/cm ³)	C _L (mm/μs)	C _S (mm/μs)		Density (g/cm ³)	C _L (mm/μs)	C _S (mm/μs)
158 zirconia (ZrO ₂), sintered	4.224	5.88	3.35	187 elkonite 2125C, sintered,			
159 albitite, Sylmar, Pennsylvania	2.611	6.46	3.07	copper-infiltrated tungsten			
160 AlVC8	3.500	8.94	5.25	(25 wt% WC)	9.748	4.18	2.15
161 anorthosite, Tahawus,				188 elkonite TC10, sintered,			
New York	2.740	7.05	3.68	copper-infiltrated tungsten			
162 bronzitite, Stillwater				(55% WC)	11.670	5.41	2.95
Complex, Montana	3.280	7.86	4.41	189 elkonite G-12, sintered,			
163 corundum (Al ₂ O ₃)/5 wt%				silver-infiltrated WC			
fused quartz (SiO ₂), sintered	3.665	9.94	5.92	(40 wt% WC)	11.900	4.37	2.18
164 corundum (Al ₂ O ₃)/15 wt%				190 elkonite G-13, sintered,			
fused quartz (SiO ₂), sintered	3.420	8.69	5.18	silver-infiltrated WC			
165 diabase, Centreville, Virginia	2.990	6.37	3.74	(50 wt% WC)	12.220	4.42	2.34
166 diabase, Frederick, Maryland	3.015	6.74	3.81	191 elkonite G-14, sintered,			
167 dunite (iron-rich), Mooihoek				silver-infiltrated WC			
Mine, Transvaal	3.800	7.17	4.05	(62 wt% WC)	13.360	4.82	2.47
168 dunite, Twin Sisters Peaks,				192 elkonite 3042, sintered,			
Washington	3.320	8.77	4.86	silver-infiltrated WC			
169 eclogite, Healdsburg,				(43 wt% WC)	12.100	4.46	2.33
California	3.420	7.71	4.42	193 elkonite 20S, sintered,			
170 eclogite, Sunnmore, Norway	3.560	7.35	4.44	silver-infiltrated tungsten			
171 granite, Westerly, Rhode				(71 wt% WC)	15.520	4.29	2.25
Island	2.637	5.33	3.28	194 elkonite 35S, sintered,			
172 iron oxide (FeO)/10 wt%				silver-infiltrated tungsten			
periclase (MgO)	5.106	5.40	2.84	(68 wt% WC)	14.610	4.05	2.12
173 jadeite, Burma	3.330	8.67	5.06	195 elkonite 50S, sintered,			
174 Pyrex	2.230	5.56	3.45	silver-infiltrated tungsten			
175 tuff, Nevada (Snubber				(51 wt% WC)	13.210	3.79	1.98
tunnel, station 0A, air dry)	1.392	1.99	1.22	196 elkonite 4050, sintered,			
176 tuff, Nevada (Snubber				silver-infiltrated tungsten			
tunnel, station 0B, air dry)	1.316	1.88	1.13	(53 wt% WC)	13.010	3.66	1.92
177 tuff, Nevada (Snubber				197 hematite (Fe ₂ O ₃)/25.9 wt%			
tunnel, station 25, air dry)	1.613	1.95	1.29	iron, cermet	5.529	4.15	2.48
178 tuff, Nevada (Snubber				198 lithium tetraborate (LiB ₃ O ₄)/			
tunnel, station 475, air dry)	1.532	1.76	1.16	10 wt% epoxy	2.160	4.91	2.95
179 tuff, Nevada (Snubber				199 tantalum carbide (Ta ₄ C)/			
tunnel, station 850L, air dry)	1.776	2.51	1.65	48.4 wt% tantalum	15.600	4.94	2.63
180 boron/23 wt% nylon	1.797	4.86	2.91	200 thorium dioxide (ThO ₂)/			
181 copper/27.2 wt% boron				13.4 wt% molybdenum	9.459	6.26	3.69
carbide	4.822	5.86	3.37	201 tungsten carbide (WC)/			
182 corundum (Al ₂ O ₃)/16.8 wt%				5.3 wt% cobalt, hot-pressed	15.000	6.89	4.18
fine-grain aluminum, cermet	3.649	9.07	5.24	202 tungsten carbide (WC)/			
183 corundum (Al ₂ O ₃)/16.8 wt%				12 wt% cobalt, cermet	13.970	6.58	3.92
large-grain aluminum, cermet	3.651	9.07	5.26	203 PBX 9404 (high-explosive			
184 elkonite 1W3, sintered,				neutronic mock-up)	1.618	2.81	1.48
copper-infiltrated tungsten				204 PBX 9404 (high-explosive			
(55 wt% WC)	12.420	4.55	2.66	density mock-up)	1.870	3.15	1.57
185 elkonite 3W3, sintered,				205 epoxy resin	1.584	2.87	1.48
copper-infiltrated tungsten				206 epoxy resin	1.192	2.63	1.16
(69 wt% WC)	13.800	4.76	2.50	207 Kel-F	2.133	1.74	0.77
186 elkonite 10W3, sintered,				208 Lucite	1.184	2.69	1.38
copper-infiltrated tungsten				209 4-methyl-1-pentene	0.829	2.19	1.08
(76 wt% WC)	14.870	4.77	2.54	210 Micarta	1.404	2.67	1.50

TABLE (cont)

	Density (g/cm ³)	C _L (mm/μs)	C _S (mm/μs)		Density (g/cm ³)	C _L (mm/μs)	C _S (mm/μs)
211 nylon (polyamide/Polyenco 101, type 6/6, annealed)	1.140	2.54	1.08	223 X-0228, 95 wt% nitroguanidine/5 wt% Estane	1.690	3.35	1.50
212 paraffin	0.919	2.18	0.83	224 PBX 9011-04, 85 wt% HMX/15 wt% estane	1.770	2.89	1.38
213 phenoxy	1.178	2.50	1.07	225 PBX 9010-02, 90 wt% RDX/10 wt% Kel-F	1.780	2.72	1.47
214 Plexiglas	1.189	2.72	1.36	226 PBX 9407, 94 wt% RDX/ 6 wt% Exon	1.780	3.04	1.70
215 polycarbonate	1.194	2.18	0.88	227 PBX 9404, 94 wt% HMX/ 3 wt% nitrocellulose/3 wt% chloroethylphosphate	1.830	2.90	1.57
216 polyethylene	0.916	2.04	0.66	228 DATB	1.780	2.99	1.55
217 polyurethane	1.265	2.38	1.03	229 TATB	1.870	1.98	1.16
218 Teflon	2.151	1.23	0.41	230 TNT	1.610	2.48	1.34
219 baratol, 76 wt% Ba(NO ₃) ₂ / 24 wt% TNT	2.538	2.95	1.48	231 Tetryl	1.680	2.27	1.24
220 Composition B-3, 60 wt% RDX/40 wt% TNT	1.726	3.12	1.71	232 RDX	1.740	2.12	1.35
221 octol, 75 wt% HMX/ 25 wt% TNT	1.824	3.14	1.65	233 900-10 (inert)	1.840	3.22	1.56
222 cyclotol, 75 wt% RDX/ 25 wt% TNT	1.752	3.12	1.69	234 905-03 (inert)	1.610	2.70	1.48

INDEX

albite 482
alumina 152-155, 479
aluminum 440-444
aluminum, 2024 63-78, 414-439, 451-457, 478
aluminum, 6061 79, 445, 458-461, 478
aluminum, 921T 62
aluminum alloys 480
aluminum oxide 202
AlVC8 482
andalusite 481
anorthosite 482
anthracene 481
antimony 1
baratol 20, 77, 106, 155, 156, 159, 172, 173, 189, 190, 192, 193, 195, 198, 200, 238, 239, 483
barium 480
barium nitrate 244
beryllium 14-19, 477, 480
beryllium oxide 156-160, 479, 481
bismuth 1, 480
boron 20, 477, 480, 482
boron carbide 161-170, 479
boron nitride 171, 479
brass 480
bronzite 482
cadmium 480
calcium 480
calcium carbonate 172

carbon 21-24, 480
cerium 480
chromium 477
cobalt 480
Comp B 40, 76, 78, 98, 158, 162-164, 181, 188, 197, 202, 226, 240, 241, 414-450, 473
Comp B-3 242, 243, 473, 483
copper 477, 480, 482
copper, OFHC 82-100, 446-450, 462-465, 476, 480
copper alloys 80, 478
corundum 202, 203, 481, 482
cyanuric acid 246, 248
cyclotol 74, 75, 483
DATB 483
diabase 220, 482
Dowmetal 480
dunite 482
dysprosium 480
eclogite 482
elkonite 482
epoxy resin 482
erbium 480
fiducial impact surface (FIS) 7
free-surface condenser method 2
gadolinium 480
gas shale, Devonian 204-219
germanium 25, 477
gold alloys 101, 478, 480
granite 482
grounded guard ring gages 10, 11
hafnium 480
hafnium titanate 173, 174, 479
hematite 481, 482
HMX 280, 281
holmium 480
Hugoniot elastic limit data 3, 477-479
ilmenite 481
Inclined mirror 3
Inert 900-10 244, 245, 483
Inert 900-19 248, 249
Inert 905-03 246, 247, 483
iridium 480

iron 1, 477, 480
iron, Armco 26-36
iron-manganese alloy 102
iron oxide 482
jadeite 479, 482
Kapton 476
Kel-F 476, 482
Lagrangian analysis scheme 8
lanthanum 480
lead 37, 477, 480
lead with 3 wt% antimony 103
Lexan 224, 225, 468, 476
lithium deuteride 481
lithium hydride 175-180, 479, 481
lithium tetraborate 482
longitudinal and shear wave velocities 3, 480-483
Lucite 482
magnesia 479
magnesium 480
magnesium alloys 104, 105, 478, 480
magnesium oxide 202
magnetite 481
Manganin alloy 7
Manganin gage 3, 7, 8
Manganin gage calibration 9
mercury 38
4-methyl-1-pentene 482
Micarta 482
molybdenum 477, 480
molybdenum alloys 106, 107, 478
neodymium 480
nickel alloys 478, 480
niobium 39, 478
nitrocellulose 246, 476
novaculite, gray Arkansas 221
nylon 483
octol 165-168, 483
optical lever arm technique 2, 3
palladium 480
paraffin 483
PBX 9010-02 483

PBX 9011-04 483
PBX 9404 21-23, 169, 170, 250-279, 451-469, 476, 482, 483
PBX 9407 483
PBX 9501 74, 75, 99, 100, 280, 281, 476
PBX 9502 282, 283, 476
Pentek 244, 476
periclase 481
PETN 203, 284-290, 292-302, 304-365, 476
phenathrene 481
phenoxy 483
platinum 480
Plexiglas 483
plutonium 480
plutonium alloys 480
polycarbonate 43
polyethylene 226, 227, 469, 483
polymethyl methacrylate (PMMA) 228-235, 426
polyurethane 483
praseodymium 480
pulse transmission technique 3
pyrene 481
Pyrex 482
quartz 481
quartz gage 2, 3, 10
quartz-gage front-back assembly 11
RDX 242, 483
rhenium 480
rhodium 480
samarium 480
scandium 480
shunted guard ring gage 10
silicon 40, 478, 480
silicon carbide 481
silicon dioxide 202, 221
sillimanite 481
silver 480
sodium chloride 181-186, 481
spinel 187-189, 479, 481
steel 108-126, 466, 467, 478-480
strontium 480
tantalum 41-43, 478, 480

tantalum alloy 127, 479
tantalum carbide 190, 191, 482
TATB 282, 283, 366-385, 408, 410, 476, 483
Teflon 483
terbium 480
Tetryl 483
thorium 44, 478, 480
thorium dioxide 482
thulium 480
tin 45, 478, 480
titanium 46, 478, 480
titanium boride 192, 193, 479
TNT 96, 157, 160, 161, 182-187, 196, 199, 238, 242, 386, 387, 408, 410, 476, 483
TP-N1028 388-393
tris-beta chloroethylphosphate (CEF) 473
tuff 482
tungsten 47, 478, 480
tungsten alloys 128-133, 479
tungsten carbide 194-199, 482
uranium 48-52, 54-59, 478, 480
uranium alloys 134-149, 479-481
uranium dioxide 481
UTP-20930 394-399
Visar 3
VWC-2 400-407
wire reflection technique 2
Wood's metal 481
X 0228 483
X 0290 408-411
ytterbium 480
yttrium 480
zirconia 482
zirconium 60, 478, 480
zirconium boride 200, 479